

Stroke Rotary Bushing

Stroke Rotary Bushing
Miniature Stroke Rotary Bushing
Stroke Rotary Cage



Stroke Rotary Bushing

ST



Points

● Rotational and linear motions

With the combination of an external cylinder with cylindrical raceway and balls incorporated in the retainer, rotary and linear motion in the axial direction is possible simultaneously with rotational motion.

● Small inertia

The retainer has a high rigidity and light weight so that it has small motion inertia suitable for rolling motion and reciprocal motion in the high-speed operation.

● Small rolling frictional resistance

By building a ball with high accuracy into the precisely polished external cylinder, a small rolling frictional resistance and extremely smooth rolling motion together with reciprocal motion have been achieved.

● Wide variation

Ordinary type and heavy load type with different load rating are provided, and each are available with and without seals. You can select an optimal linear bushing for the specifications of your machine and device.

Identification Number and Specification

Example of an identification number

The specification of ST series is indicated by the identification number. Indicate the identification number, consisting of a model code, dimensions and a part code for each specification to apply.

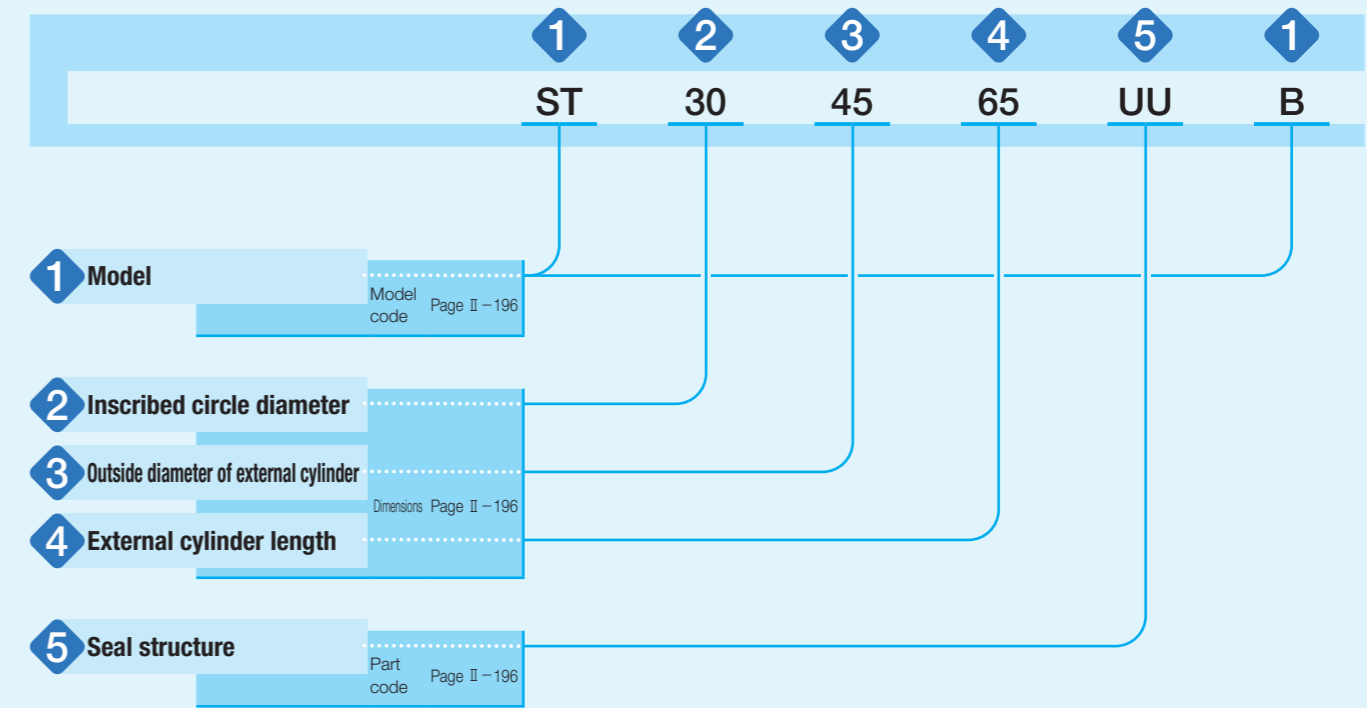



Identification Number and Specification

1 Model	Stroke Rotary Bushing (ST series)	Ordinary type : ST Heavy load type : ST...B	For applicable models and sizes, see Table 1.
2 Inscribed circle diameter		Indicate the inscribed circle diameter in mm.	
3 Outside diameter of external cylinder		Indicate the outside diameter of external cylinder in mm.	
4 External cylinder length		Indicate the external cylinder length in mm.	
5 Seal structure	Open type : No symbol With seal : UU	The models with seal type incorporate seals with superior dust protection performance for preventing intrusion of foreign substances.	

ST • STSI • BG

Identification Number and Specification

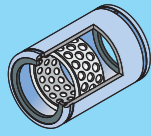
Table 1 Models and sizes of ST series

Shape	Seal structure	Model	Size																		
			4	5	6	8	10	12	16	20	25	30	35	40	45	50	55	60	70	80	90
 Ordinary type	Open type	ST	○	○	○	○	○	○	○	○	○	○	○	○	○	○	○	○	○	○	○
	With seal	ST...UU	-	-	-	○	○	○	○	○	○	○	○	○	○	○	○	○	○	○	○
 Heavy load type	Open type	ST...B	-	-	-	○	○	○	○	○	○	○	○	○	○	○	○	○	○	○	○
	With seal	ST...UUB	-	-	-	-	-	-	-	-	-	○	○	○	○	○	○	○	○	○	○

Accuracy

Since outside diameter of external cylinder is deformed by stop ring tension, calculate the measurement point from the equation (1) and use the average diameter value at the point.

$$W = 4 + L_1 / 8 \dots \dots \dots (1)$$

where, W: Distance from the end to measurement point P, mm (see Fig. 1)

L_1 : External cylinder length, mm

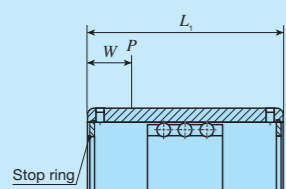

Fig. 1

Table 2 Tolerance of inscribed circle diameter and outside diameter of external cylinder unit: μm

Nominal dimensions of inscribed circle diameter F_w or outside diameter of external cylinder D mm	Tolerance of inscribed circle diameter F_w		Tolerance of outside diameter of external cylinder D_m (1)		
	Over	Incl.	High	Low	High
4	6	+18	+10	-	-
6	10	+22	+13	0	- 8
10	18	+27	+16	0	- 8
18	30	+33	+20	0	- 9
30	50	+41	+25	0	-11
50	80	+49	+30	0	-13
80	120	+58	+36	0	-15
120	150	-	-	0	-18

Note (1) D_m is an arithmetic mean value of the maximum diameter and minimum diameter obtained by two-point measurement of the outside diameter of external cylinder.

Table 3 Tolerance of external cylinder length unit: μm

Nominal dimensions of inscribed circle diameter F_w mm		Dim. L_1 tolerance of external cylinder length	
Over	Incl.	High	Low
-	20	0	-200
20	60	0	-300
60	100	0	-400

Allowance of Velocity

The ST series is capable of rotation and rotary and linear motion. However, allowance of velocity for these motions performed at the same time is obtained from the equation (2). Typical values are indicated in Table 4.

$$DN \geq D_{pw} n + 10 S n_1 \dots \dots \dots (2)$$

where, DN : Allowance of velocity (see Table 4)

n : Rotational speed, rpm

n_1 : Number of strokes per minute, cpm

S : Stroke length, mm

D_{pw} : Pitch circle diameter of balls, mm ($D_{pw} \doteq 1.15F_w$)

F_w : Inscribed circle diameter, mm

However, applicable when $n_1 \leq 5000$, $S n_1 \leq 50000$.

Table 4 Allowance of velocity

Lubrication conditions	DN
Oil lubrication	600 000
Grease lubrication	300 000

Lubrication

Grease is not pre-packed in the ST series, so please perform adequate lubrication as needed.

Both of oil lubrication and grease lubrication are available in the ST series. For grease lubrication, use of high-quality lithium-soap base grease is recommended. Oil is fed from

the oil hole on the external cylinder.

Precaution for Use

1 Fitting

Recommended fit for the ST series is indicated in Table 5. As the ST series performs rotation and rotary and linear motion at the same time, the radial internal clearance must be smaller when shock load or load accompanied by vibration is applied. Especially when vertical axis application or high accuracy motion is required, it is recommended to set the radial internal clearance at zero or under a slightly-preloaded condition.

Excessive preload will shorten the life, so be careful not to set lower limit value of radial internal clearance below the value stated in Table 6.

Table 5 Recommended fit

Operational conditions	Tolerance class	
	Shaft	Housing hole
Normal operational conditions	k5, m5	H6, H7
For vertical axis or high accuracy	n5, p6	J6, J7

Table 6 Lower limit of radial internal clearance unit: μm

Nominal dimensions of inscribed circle diameter F_w mm		Lower limit of radial internal clearance
Over	Incl.	
4	6	- 2
6	10	- 3
10	18	- 4
18	30	- 5
30	50	- 6
50	80	- 8
80	100	-10

2 Raceway

Since ST series operates with a shaft as a raceway surface, the shaft should be heat-treated and ground. Recommended values for surface hardness and roughness of the shaft are shown in Table 7 and the recommended value for the minimum effective hardening depth is shown in Table 8.

Table 7 Surface hardness and roughness of raceway

Item	Recommended value	Remark
Surface hardness	58~64HRC	When the surface hardness is low, multiply the load rating by hardness factor (1).
Surface roughness	0.2 μmRa or lower (0.8 μmRy or lower)	Where accuracy standard is low, around 0.8 μmRa (3.2 μmRy) is also allowed.

Note (1) For hardness factor, refer to Fig. 3 in page III-5.

Table 8 Minimum effective hardening depth of shaft unit: mm

Shaft diameter		Recommended value for minimum effective hardening depth
Over	Incl.	
-	28	0.8
28	50	1.0
50	100	1.5

3 Stroke length

For stroke length used, 80% of the maximum stroke length stated in the dimension table is recommended.

4 Operating temperature

The maximum operating temperature is 120°C and temperature up to 100°C is allowed for continuous operation. When the temperature exceeds 100°C, contact **IKO**.

5 Assembly operation of external cylinder and shaft

When inserting a shaft, be careful not to shock the ball. After assembling, correct the position of the retainer to be in the center of the external cylinder. After assembling the external cylinder to the housing, insert the shaft softly. Move the retainer as well as the shaft until they contact one side of the surface and stop. Then push the shaft not to damage balls or raceway to the position a half of the maximum stroke length and return it by the same length (a half of the maximum stroke) so that the retainer is positioned regularly at the center of the external cylinder.

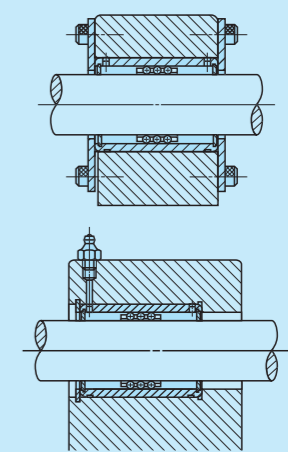
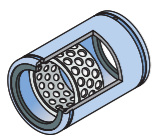
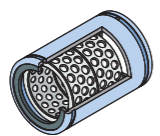
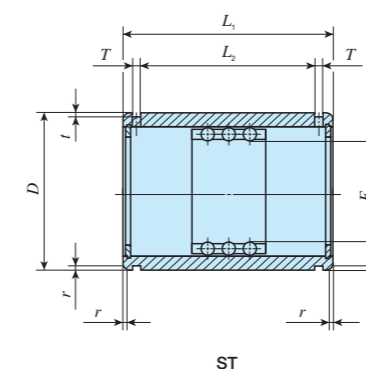

Fig. 2 Mounting examples

IKO Stroke Rotary Bushing **Open Type**

	Ordinary type								Heavy load type																			
Shape	ST								ST...B																			
																												
Size	4	5	6	8	10	12	16	—	—	—	8	10	12	16	20	25	30	35	40	45	50	20	25	30	35	40	45	50
	55	60	70	80	90	100	—	—	—	55	60	70	80	90	100	—	—	—	—	—	—	—	55	60	70	80	90	100



ST

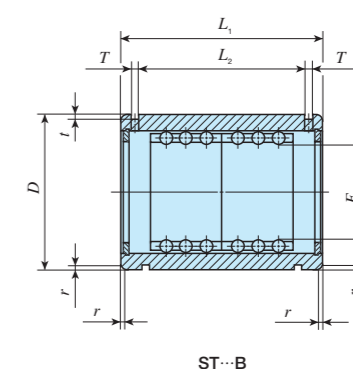

ST...B

Shaft diameter mm	Identification number				Nominal dimensions mm									Maximum stroke length mm	ST			ST...B		
	Ordinary type	Mass (Ref.) g	Heavy load type	Mass (Ref.) g	F_w	D	L_1	L_2	T	t	r	Basic dynamic load rating C N	Basic static load rating C_0 N		Maximum stroke length mm	Basic dynamic load rating C N	Basic static load rating C_0 N			
4	ST 4814	2.9	—	—	4	8	14	9	1.1	0.25	0.3	10	112	59.5	—	—	—			
5	ST 51016	5.6	—	—	5	10	16	10.6	1.1	0.25	0.3	13	121	68.3	—	—	—			
6	ST 61219	8.9	—	—	6	12	19	13.2	1.1	0.25	0.3	15	278	168	—	—	—			
8	ST 81524	15.6	ST 81524 B	16.8	8	15	24	17.1	1.5	0.5	0.5	24	315	211	8	512	422			
10	ST 101930	28.8	ST 101930 B	31.2	10	19	30	22.7	1.5	0.5	0.5	30	659	466	8	1 070	932			
12	ST 122332	42	ST 122332 B	46	12	23	32	24.5	1.5	0.5	0.5	32	1 110	822	8	1 800	1 640			
16	ST 162837	71	ST 162837 B	75	16	28	37	29.1	1.5	0.5	0.5	40	1 230	998	16	1 990	2 000			
20	ST 203245	99	ST 203245 B	106	20	32	45	35.8	2	0.5	0.5	54	1 390	1 250	28	2 250	2 500			
25	ST 253745	117	ST 253745 B	125	25	37	45	35.8	2	0.5	1	54	1 450	1 430	28	2 360	2 850			
30	ST 304565	205	ST 304565 B	220	30	45	65	53.5	2.5	0.5	1	82	3 110	3 160	44	5 060	6 320			
35	ST 355270	329	ST 355270 B	346	35	52	70	58.5	2.5	0.7	1.5	92	3 290	3 550	54	5 340	7 100			
40	ST 406080	516	ST 406080 B	540	40	60	80	68.3	2.5	0.7	1.5	108	4 340	4 810	66	7 050	9 630			
45	ST 456580	563	ST 456580 B	588	45	65	80	68.3	2.5	0.7	1.5	108	4 550	5 330	66	7 390	10 700			
50	ST 5072100	827	ST 5072100 B	862	50	72	100	86.4	3	1	1.5	138	5 790	6 970	88	9 400	13 900			
55	ST 5580100	1 160	ST 5580100 B	1 200	55	80	100	86.4	3	1	2	138	6 030	7 630	88	9 800	15 300			
60	ST 6085100	1 240	ST 6085100 B	1 290	60	85	100	86.4	3	1	2	138	6 260	8 300	88	10 200	16 600			
70	ST 7095100	1 400	ST 7095100 B	1 450	70	95	100	86.4	3	1	2	138	6 510	9 320	88	10 600	18 600			
80	ST 80110100	2 050	ST 80110100 B	2 110	80	110	100	86	3	1.5	2	132	8 230	12 200	76	13 400	24 400			
90	ST 90120100	2 250	ST 90120100 B	2 330	90	120	100	86	3	1.5	2	132	8 550	13 500	76	13 900	27 000			
100	ST 100130100	2 440	ST 100130100 B	2 520	100	130	100	86	3	1.5	2	132	8 820	14 800	76	14 300	29 500			

ST • STSI • BG

IKO Stroke Rotary Bushing **With Seal**

	Ordinary type						Heavy load type					
Shape	ST...UU						ST...UUB					
Size	8	10	12	16	20	25	—	—	—	—	—	—
	30	35	40	45	50	55	30	35	40	45	50	55
	60	70	80	90	100		60	70	80	90	100	

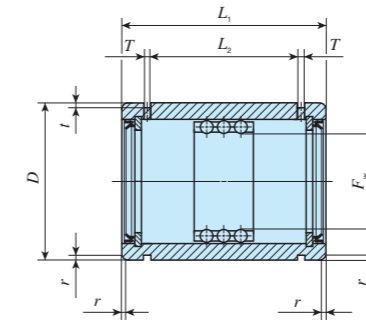

ST...UU

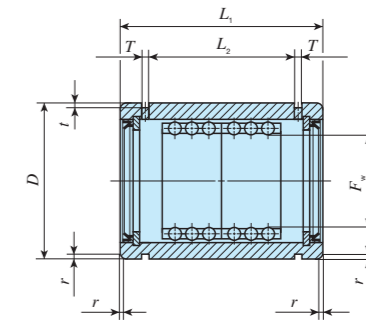

ST...UUB

Shaft diameter mm	Identification number				Nominal dimensions mm									ST...UU			ST...UUB		
	Ordinary type	Mass (Ref.) g	Heavy load type	Mass (Ref.) g	F_w	D	L_1	L_2	T	t	r	Maximum stroke length mm	Basic dynamic load rating C N	Basic static load rating C_0 N	Maximum stroke length mm	Basic dynamic load rating C N	Basic static load rating C_0 N		
8	ST 81524 UU	16.5	—	—	8	15	24	12.3	1.5	0.5	0.5	14	315	211	—	—	—		
10	ST 101930 UU	30.7	—	—	10	19	30	15.5	1.5	0.5	0.5	16	659	466	—	—	—		
12	ST 122332 UU	45	—	—	12	23	32	17.1	1.5	0.5	0.5	17	1 110	822	—	—	—		
16	ST 162837 UU	74	—	—	16	28	37	21.1	1.5	0.5	0.5	24	1 230	998	—	—	—		
20	ST 203245 UU	107	—	—	20	32	45	26.8	2	0.5	0.5	32	1 390	1 250	—	—	—		
25	ST 253745 UU	121	—	—	25	37	45	26.8	2	0.5	1	32	1 450	1 430	—	—	—		
30	ST 304565 UU	215	ST 304565 UU B	230	30	45	65	45.1	2.5	0.5	1	65	3 110	3 160	27	5 060	6 320		
35	ST 355270 UU	342	ST 355270 UU B	359	35	52	70	50.1	2.5	0.7	1.5	75	3 290	3 550	37	5 340	7 100		
40	ST 406080 UU	529	ST 406080 UU B	553	40	60	80	59.9	2.5	0.7	1.5	91	4 340	4 810	49	7 050	9 630		
45	ST 456580 UU	577	ST 456580 UU B	602	45	65	80	59.9	2.5	0.7	1.5	91	4 550	5 330	49	7 390	10 700		
50	ST 5072100 UU	836	ST 5072100 UU B	871	50	72	100	77.4	3	1	1.5	120	5 790	6 970	70	9 400	13 900		
55	ST 5580100 UU	1 190	ST 5580100 UU B	1 230	55	80	100	77.4	3	1	2	120	6 030	7 630	70	9 800	15 300		
60	ST 6085100 UU	1 270	ST 6085100 UU B	1 320	60	85	100	77.4	3	1	2	120	6 260	8 300	70	10 200	16 600		
70	ST 7095100 UU	1 430	ST 7095100 UU B	1 480	70	95	100	77.4	3	1	2	120	6 510	9 320	70	10 600	18 600		
80	ST 80110100 UU	2 080	ST 80110100 UU B	2 140	80	110	100	77	3	1.5	2	114	8 230	12 200	58	13 400	24 400		
90	ST 90120100 UU	2 290	ST 90120100 UU B	2 370	90	120	100	77	3	1.5	2	114	8 550	13 500	58	13 900	27 000		
100	ST 100130100 UU	2 540	ST 100130100 UU B	2 620	100	130	100	77	3	1.5	2	114	8 820	14 800	58	14 300	29 500		

ST • STSI • BG

Miniature Stroke Rotary Bushing

STSI



Points

1 Rotational and linear motions

With the combination of an external cylinder with cylindrical raceway and balls incorporated in the retainer, rotary and linear motion in the axial direction is possible simultaneously with rotational motion.

2 Super small size

With the ultra-small sized balls incorporated in a thin external cylinder, small diameter and small sectional height are realized.

3 Super precision

Balls of high accuracy are incorporated with super-finished external cylinder and shaft to be adjusted to zero or minimal amount of preload, which realizes rotational motion and rotary and linear motion of high accuracy.

4 Extremely smooth operation

Since each component is precisely grounded and adjusted to ideal preload condition, extremely smooth and stable operation with small frictional resistance for long term can be achieved.

Identification Number and Specification

Example of an identification number

The specification of STSI series is indicated by the identification number. Indicate the identification number, consisting of a model code, dimensions, length, and a selection code for each specification to apply.

	1	2	3	4	5	6	7	1	8
Assembled set									
With a shaft	STSI	4			20 - 15 - 50				
Without a shaft	STS	4			20 - 15				/M1
Part									
External cylinder	OR		6	8	20			A	/M1
Ball cage	BK	4	6			15		A	
Shaft	SF	4					50	A	/M1

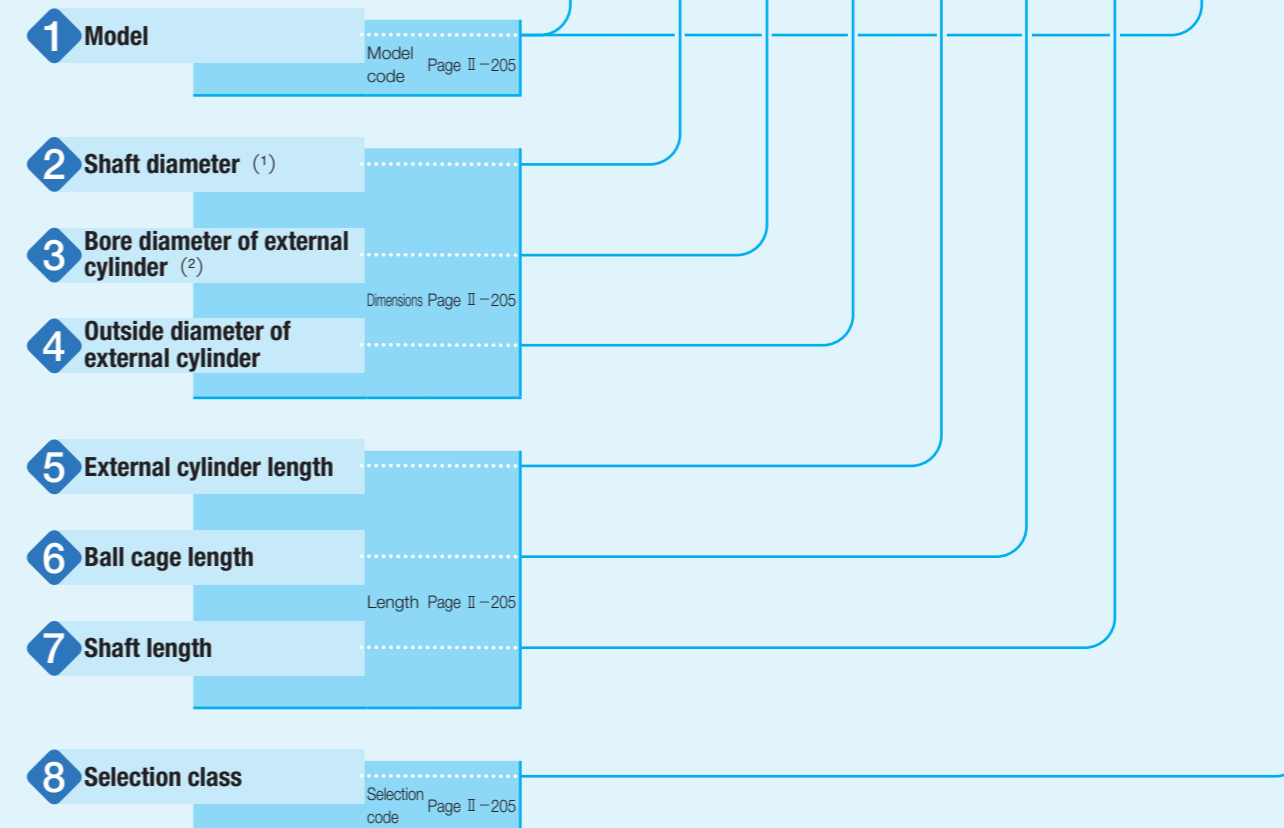

Notes (1) Indicates inscribed circle diameter for assembled set without a shaft or ball cage.
(2) Indicates circumscribed circle diameter for ball cage.

Identification Number and Specification

1 Model	Miniature Stroke Rotary Bushing (STSI series)	Assembled set with a shaft : STSI Assembled set without a shaft : STS External cylinder : OR...A Ball cage : BK...A Shaft : SF...A
2 Shaft diameter		Indicate the shaft diameter in mm. Indicates inscribed circle diameter for assembled set without a shaft or ball cage.
3 Bore diameter of external cylinder		Indicate the bore diameter of external cylinder in mm. Indicates circumscribed circle diameter for ball cage.
4 Outside diameter of external cylinder		Indicate the outside diameter of external cylinder in mm.
5 External cylinder length		Indicate the external cylinder length in mm.
6 Ball cage length		Indicate the ball cage length in mm.
7 Shaft length		Indicate the shaft length in mm.
8 Selection class	M1 class : M1 M2 class : M2 M3 class : M3	Selection code and tolerances are shown in Table 3. For combination of each part, assemble parts with the same selection code.

Table 1 Models of STSI series

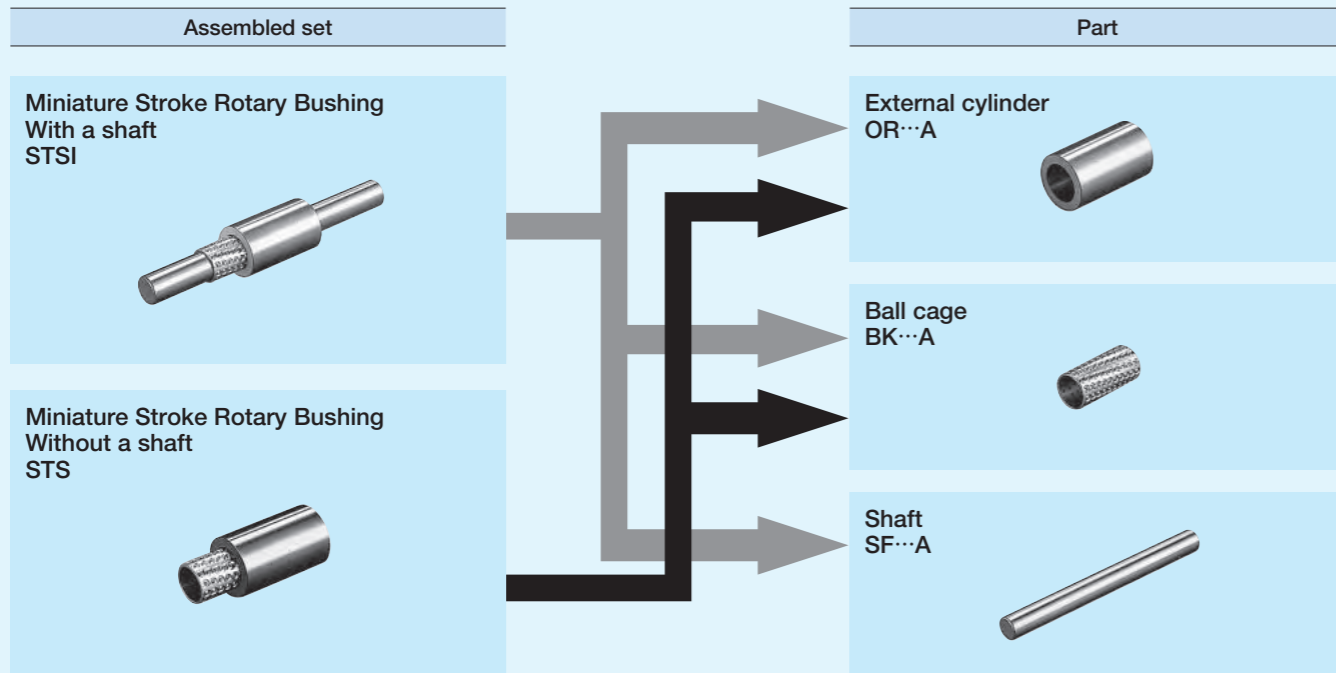

Accuracy

Table 2 Tolerance and allowance

Nominal dimensions of outside diameter of external cylinder mm		Tolerance of outside diameter of external cylinder μm		Radial runout of outside diameter of external cylinder μm	Tolerance of length of external cylinder and shaft mm
Over	Incl.	High	Low		
3	6	0	-5	8	± 0.1
6	10	0	-6		
10	18	0	-8		
18	30	0	-9	9	

Table 3 Selection code and tolerance

unit: μm

Selection code	Tolerance of bore diameter of external cylinder		Tolerance of inscribed circle diameter		Tolerance of shaft diameter	
	High	Low	High	Low	High	Low
M1	-1	-3	-1	-3	0	-1
M2	-2	-4	-2	-4	-1	-2
M3	-3	-5	-3	-5	-2	-3

Load Rating

Load rating of the STSI series represents the value obtained when load is evenly distributed without the ball incorporated in the ball cage being dropped from the external cylinder and shaft end.

Lubrication

Grease is not pre-packed in the STSI series, so please perform adequate lubrication as needed. Both of oil lubrication and grease lubrication are available in the STSI series. For grease lubrication, it is typically applied lightly to the shaft and raceway of the external cylinder. Use of high-quality lithium-soap base grease is recommended for the grease to use.

Precaution for Use

1 Fitting

The STSI series is assembled to slight preload state to obtain high motion accuracy. Use external cylinder and housing hole of the STSI series with clearance fit to avoid any effect of press-fitting on inscribed circle diameter. In addition, for combination of an external cylinder, a ball cage and a shaft, select an external cylinder and a shaft with the same selection code to be combined with a ball cage.

2 Operating temperature

The maximum operating temperature is 120°C and temperature up to 100°C is allowed for continuous operation. When the temperature exceeds 100°C, contact **IKO**.

3 Mounting

Typically, to fix the external cylinder and housing hole, the external cylinder end is fixed to the axial direction with stop ring or adhesive agent is used.

The ball cage is mounted through the shaft after the external cylinder is fixed to the housing hole. At this point, mounting becomes easier if the ball cage is shifted by one half of assembly insertion amount of the shaft in insert direction of the shaft so that the ball cage is positioned at the regular position after mounting.

4 Insertion of shaft

When inserting a shaft into an external cylinder, be careful not to pry open or give shock to the shaft.

IKO Miniature Stroke Rotary Bushing

	Assembled set with a shaft				Assembled set without a shaft				External cylinder				Ball cage				Shaft			
Shape	STSI				STS				OR...A				BK...A				SF...A			
Size	2	3	4	5	2	3	4	5	2	3	4	5	2	3	4	5	2	3	4	5
	6	8	10	12	6	8	10	12	6	8	10	12	6	8	10	12	6	8	10	12

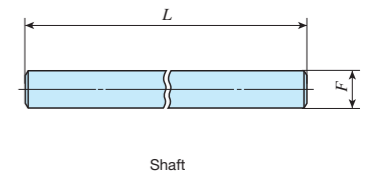
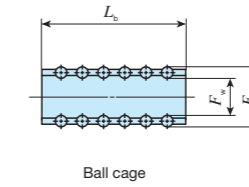
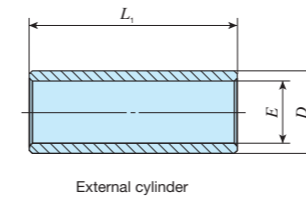

Shaft diameter mm	Identification number of assembled set without a shaft	External cylinder					Ball cage					Basic static load rating ⁽¹⁾ C ₀ N	Shaft			Identification number of assembled set with a shaft			
		Identification number	Mass (Ref.) g	Nominal dimensions mm			Identification number	Mass (Ref.) g	F _w	Nominal dimensions mm			Identification number	Mass (Ref.) g	Nominal dimensions mm				
				E	D	L ₁					E _w	L _b				F	L		
2	STS 2 L ₁ -L _b	OR 3 5 10 A	0.9	3.2	5	10	BK 2 3 5 A	0.1	2		3.2	5	10.5	SF 2 20 A	0.5	2	20	STSI 2 L ₁ -L _b -L	
		OR 3 5 15 A	1.3				BK 2 3 10 A	0.3						SF 2 30 A	0.7				30
3	STS 3 L ₁ -L _b	OR 5 7 10 A	1.5	5	7	10	BK 3 5 10 A	0.7	3		5	10	38.4	SF 3 50 A	2.8	3	50	STSI 3 L ₁ -L _b -L	
		OR 5 7 20 A	2.9				BK 3 5 15 A	1.1						SF 3 60 A	3.3				60
		OR 5 7 30 A	4.4				BK 3 5 20 A	1.4											
4	STS 4 L ₁ -L _b	OR 6 8 10 A	1.7	6	8	10	BK 4 6 10 A	0.9	4		6	10	59.5	SF 4 50 A	4.9	4	50	STSI 4 L ₁ -L _b -L	
		OR 6 8 20 A	3.4				BK 4 6 15 A	1.3						SF 4 60 A	5.9				60
		OR 6 8 30 A	5.2				BK 4 6 20 A	1.8											
5	STS 5 L ₁ -L _b	OR 7 10 10 A	3.1	7	10	10	BK 5 7 10 A	1.0	5		7	10	81	SF 5 50 A	7.7	5	50	STSI 5 L ₁ -L _b -L	
		OR 7 10 20 A	6.3				BK 5 7 15 A	1.6						SF 5 80 A	12.3				80
		OR 7 10 30 A	9.4				BK 5 7 20 A	2.0											
6	STS 6 L ₁ -L _b	OR 8 11 20 A	7.0	8	11	20	BK 6 8 10 A	1.2	6		8	10	103	SF 6 50 A	11.1	6	50	STSI 6 L ₁ -L _b -L	
		OR 8 11 30 A	10.5				BK 6 8 15 A	1.8						SF 6 80 A	17.7				80
		OR 8 11 40 A	14.1				BK 6 8 20 A	2.3											
8	STS 8 L ₁ -L _b	OR 10 13 20 A	8.5	10	13	20	BK 8 10 10 A	1.6	8		10	10	105	SF 8 50 A	19.7	8	50	STSI 8 L ₁ -L _b -L	
		OR 10 13 30 A	12.7				BK 8 10 15 A	2.4						SF 8 80 A	31.5				80
		OR 10 13 40 A	17.0				BK 8 10 20 A	3.2						SF 8 90 A	35.5				90
10	STS 10 L ₁ -L _b	OR 12 18 20 A	22.2	12	18	20	BK 10 12 15 A	2.8	10		12	15	191	SF 10 80 A	49.3	10	80	STSI 10 L ₁ -L _b -L	
		OR 12 18 30 A	33.3				BK 10 12 20 A	3.8						SF 10 100 A	61.6				100
		OR 12 18 43 A	47.7				BK 10 12 25 A	4.8						SF 10 120 A	74.0				120
12	STS 12 L ₁ -L _b	OR 14 20 25 A	31.4	14	20	25	BK 12 14 20 A	4.3	12		14	20	341	SF 12 80 A	71.0	12	80	STSI 12 L ₁ -L _b -L	
		OR 14 20 30 A	37.7				BK 12 14 25 A	5.4						SF 12 100 A	88.8				100
		OR 14 20 35 A	44.0				BK 12 14 30 A	6.1						SF 12 120 A	106.5				120
		OR 14 20 40 A	50.3																

Note ⁽¹⁾ Represents the value when load is evenly distributed without the ball incorporated in the ball cage being dropped from the external cylinder end.

Remark: L₁, L_b, and L in the identification number field of assembled set without a shaft and assembled set with a shaft represent length of the external cylinder, length of the ball cage, and length of the shaft in the dimension table.

ST • STSI • BG

Stroke Rotary Cage

BG

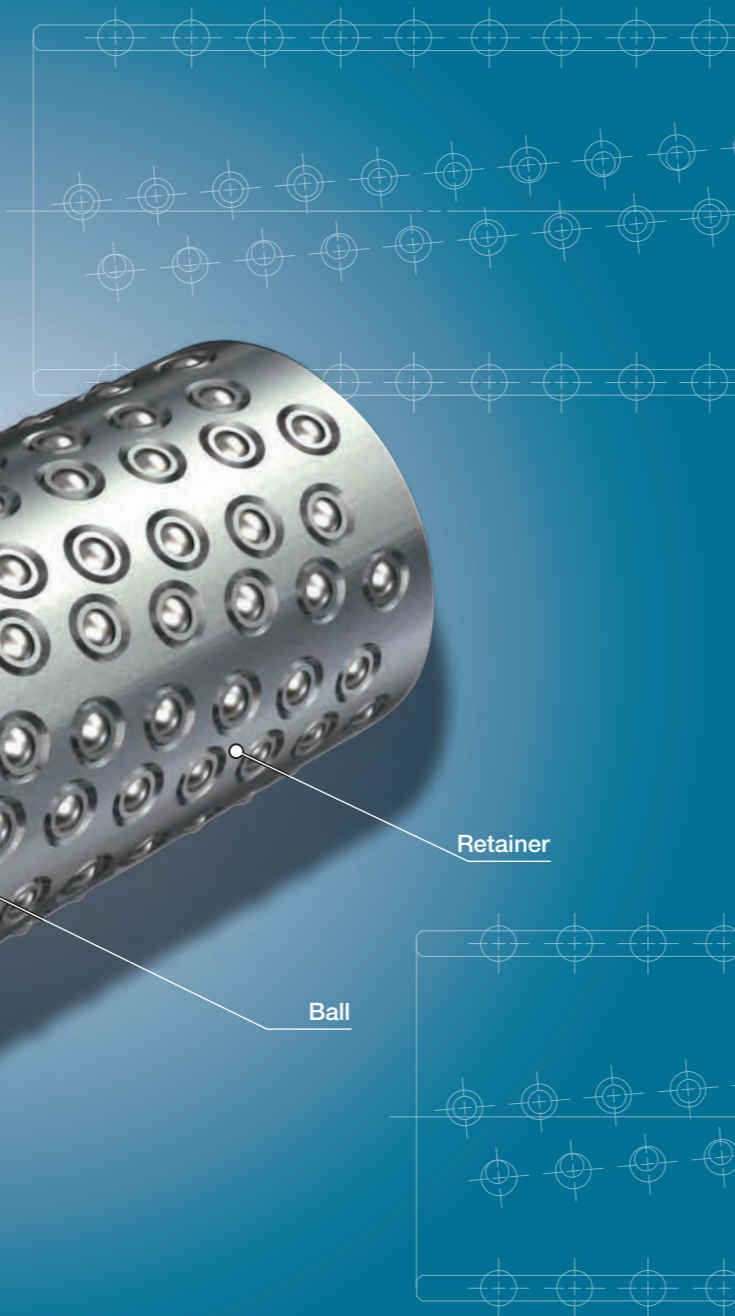
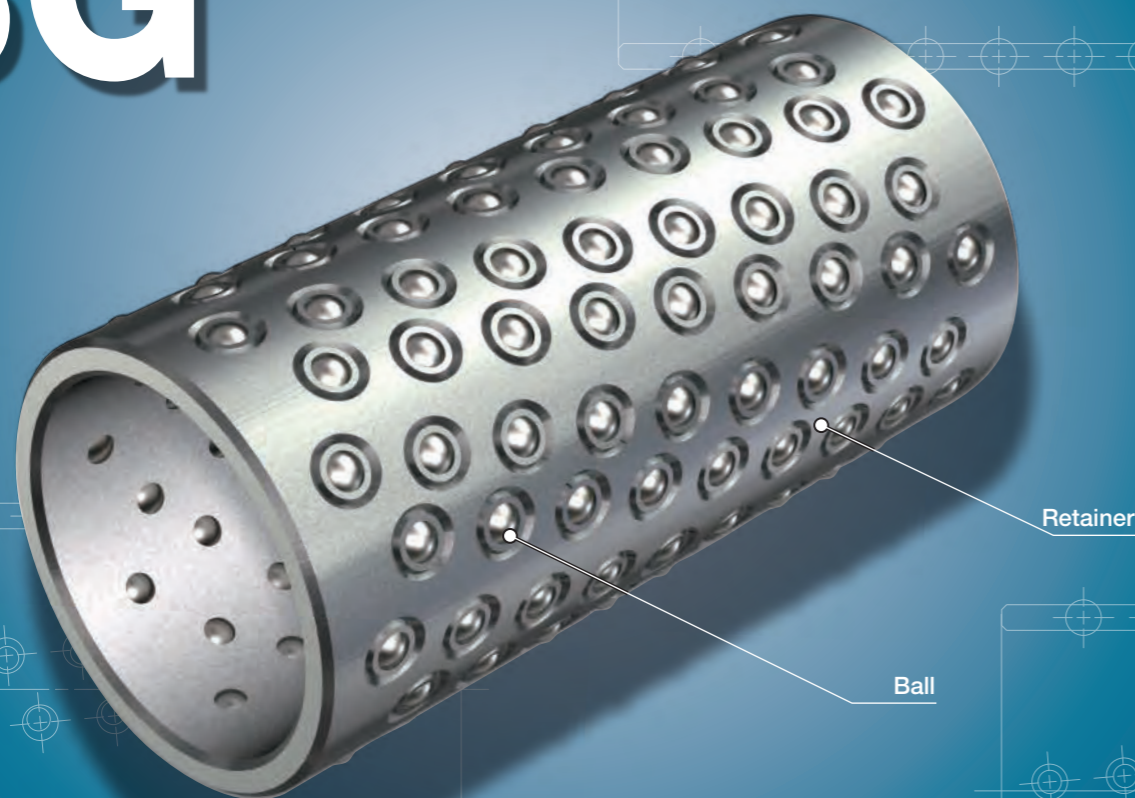

Points

● Rotational and linear motions

High-accuracy balls incorporated into the retainer make use of the raceway accuracy to allow high-accuracy rotational motion and rotary and linear motion.

● Large load rating and high rigidity

In the retainer, balls are incorporated as many as possible. So the load ratings are large and the rigidity is high with small elastic deformation even under fluctuating load or offset load.

● Superior high speed operation

As the retainers have high rigidity and light in weight with low inertia, this series is suitable for abrupt operations such as high-speed rotary and linear motion in axial direction.

● Long life

Each ball held in the retainer is arranged in a spiral formation in order to prevent the balls from tracing the same path. Rolling contact fatigue of the shaft and housing raceways is thereby minimized, and stable high accuracy can be assured for long periods of time.

Identification Number and Specification

Example of an identification number

The specification of BG series is indicated by the identification number. Indicate the identification number, consisting of a model code and dimensions.

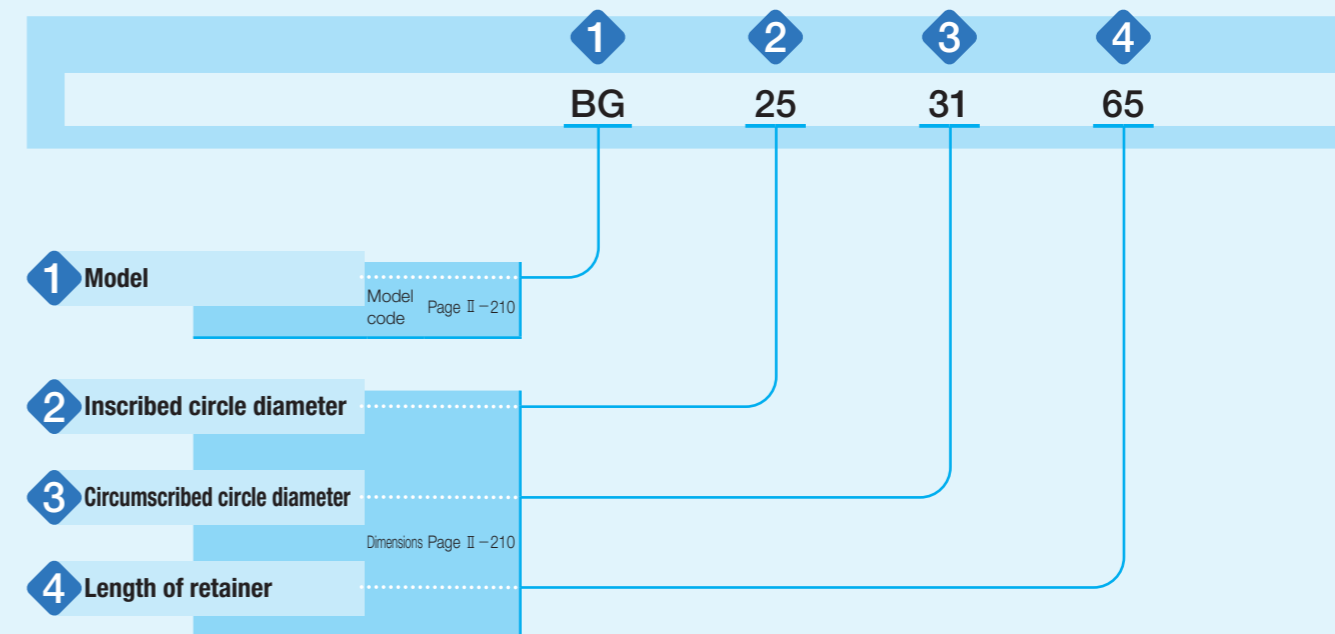

Identification Number and Specification

1 Model	Stroke Rotary Cage (BG series)	: BG
2 Inscribed circle diameter		Indicate the inscribed circle diameter in mm.
3 Circumscribed circle diameter		Indicate the circumscribed circle diameter in mm.
4 Length of retainer		Indicate the length of retainer in mm.

Allowance of Velocity

The BG series is capable of rotation and rotary and linear motion. However, allowance of velocity for these motions performed at the same time is obtained from the equation (1). Typical values are indicated in Table 1.

$$DN \geq D_{pw} n + 10 S n_1 \dots \dots \dots (1)$$

where, DN : Allowance of velocity (see Table 1)

n : Rotational speed, rpm

n_1 : Number of strokes per minute, cpm

S : Stroke length, mm

D_{pw} : Pitch circle diameter of balls, mm

$$\left(D_{pw} = \frac{F_w + E_w}{2} \right)$$

F_w : Inscribed circle diameter, mm

E_w : Circumscribed circle diameter, mm

However, applicable when $n_1 \leq 5000$, $S n_1 \leq 50000$.

Table 1 Allowance of velocity

Lubrication conditions	DN
Oil lubrication	600 000
Grease lubrication	300 000

Precaution for Use

① Fitting

BG series is generally used with a slight radial internal clearance fit. Recommended fits are shown in Table 2. When it is used for a guide post of the press die set or high operation accuracy is required, a preload is generally given. The tolerances of dimensions of the shaft and housing bore in this case are shown in Table 3. However, since excessive preload shortens the life of Stroke Rotary Cage, it is suggested that the lower limit of radial clearance is not smaller than the value shown in Table 4.

Table 2 General fit

Tolerance class	
Shaft	Housing hole
h5, h6	H6, H7

Table 3 Tolerances of dimensions for shaft and housing hole
unit: μm

Shaft		Housing hole			
Nominal dimensions mm	h5		Nominal dimensions mm	K5	
	H	L		H	L
19	0	-9	25	+1	-8
22	0	-9	28	+1	-8
25	0	-9	31	+2	-9
28	0	-9	36	+2	-9
32	0	-11	40	+2	-9
38	0	-11	48	+2	-9

Table 4 Lower limit of radial internal clearance unit: μm

Nominal dimensions of shaft mm	Lower limit of radial internal clearance
19	-5
22	-5
25	-5
28	-7
32	-7
38	-7

② Raceway

BG series is used with a shaft and housing hole as raceway surfaces. Recommended values for surface hardness and roughness of mating raceway are shown in Table 5 and the recommended values for the minimum effective hardening depth are shown in Table 6. When some of the balls held in the retainer escape the housing raceway and operate in linear motion, it is recommended that the housing raceway ends should be slightly chamfered so that the balls enter or exit smoothly.

Table 5 Surface hardness and roughness of raceway

Item	Recommended value	Remark
Surface hardness	58~64HRC	When the surface hardness is low, multiply the load rating by hardness factor ⁽¹⁾ .
Surface roughness	0.2 μmRa or lower (0.8 μmRy or lower)	Where accuracy standard is low, around 0.8 μmRa (3.2 μmRy) is also allowed.

Note ⁽¹⁾ For hardness factor, refer to Fig. 3 in page III-5.

Table 6 Minimum effective hardening depth of raceway
unit: mm

Nominal dimensions of shaft and housing hole		Recommended value for minimum effective hardening depth
Over	Incl.	
-	28	0.8
28	50	1.0

IKO Stroke Rotary Cage

Shape	BG		
			
Size	19	22	25
	28	32	38

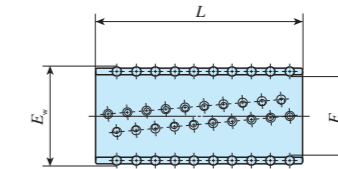

Shaft diameter mm	Identification number	Mass (Ref.) g	Nominal dimensions mm			Basic dynamic load rating ⁽¹⁾ C N	Basic static load rating ⁽¹⁾ C ₀ N
			F _w	E _w	L		
19	BG 192555*	33	19	25	55	2 330	2 600
22	BG 222860*	40	22	28	60	2 490	2 950
25	BG 253165*	48	25	31	65	2 660	3 390
28	BG 283670*	76	28	36	70	3 830	4 660
32	BG 324075*	93	32	40	75	4 480	6 030
38	BG 384880*	162	38	48	80	6 750	9 390

Note ⁽¹⁾ Basic dynamic load rating and basic static load rating are values when balls incorporated into the retainer share the load evenly without escaping the raceway.

Remark: The identification numbers with * are our semi-standard items.