

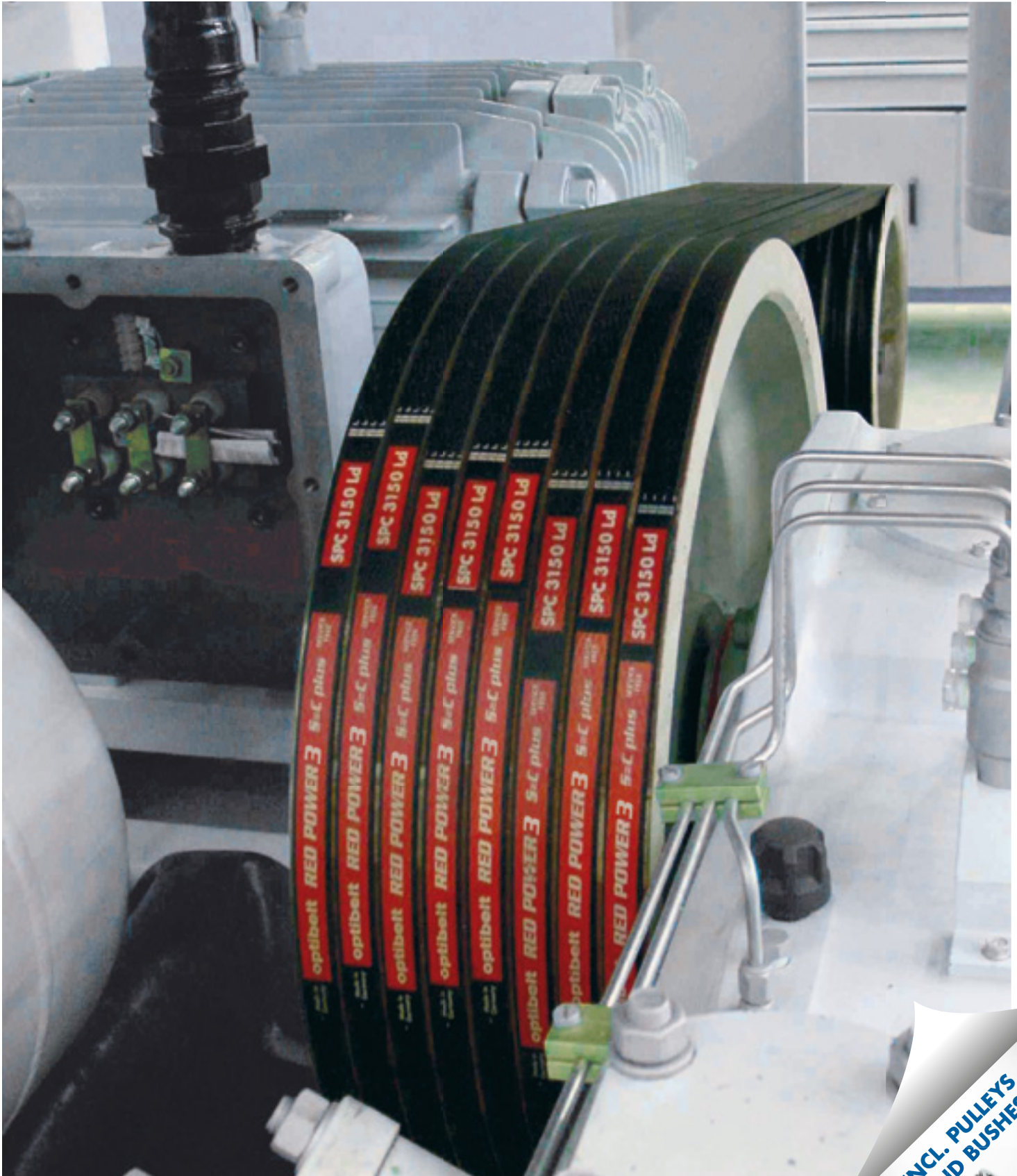

OPTIBELT TECHNICAL MANUAL V-BELT DRIVES



**INCL. PULLEYS
AND BUSHES**

TECHNICAL MANUAL

V-BELT DRIVES

This technical manual contains all important technical information and methods for the design and calculation of drives with OPTIBELT V-belts and V-grooved pulleys for industrial applications.

Our Application Technology experts offer you free support service regarding the application of our products and also help solve your drive problems. Especially regarding large volume you should make use of this service.

We offer you the optimum solution using state-of-the-art programmes, the CAP drive calculation software.

OPTIBELT WORLDWIDE





www.optibelt.com



	OPTIBELT GMBH www.optibelt.de		OPTIBELT ÖSTERREICH GMBH www.optibelt.at
	OPTIBELT (UK) LTD. www.optibelt.co.uk		OPTIBELT POLSKA SP. Z O.O. www.optibelt.pl
	OPTIBELT NEDERLAND B.V. www.optibelt.nl		ООО „OPTIBELT POWER TRANSMISSION“ www.optibelt.ru
	OPTIBELT FINLAND OY www.optibelt.fi		OPTIBELT HUNGARY KFT. www.optibelt.hu
	OPTIBELT SKANDINAVISKA AB www.optibelt.se		OPTIBELT CORPORATION www.optibelt.us
	SALES DÄNEMARK www.optibelt.dk		OPTIBELT (CANADA) INC. www.optibelt.ca
	SALES NORWEGEN www.optibelt.no		OPTIBELT DO BRASIL LTDA. www.optibelt-br.com
	OPTIBELT FRANCE SAS www.optibelt.fr		OPTIBELT ASIA PACIFIC PTE. LTD. www.optibelt.sg
	OPTIBELT AG www.optibelt.ch		OPTIBELT POWER TRANSMISSION www.optibelt.cn
	OPTIBELT GMBH www.optibelt.be		OPTIBELT POWER TRANSMISSION INDIA PVT. LTD. www.optibelt.in
	OPTIBELT ESPAÑA, S.A. www.optibelt.es		OPTIBELT AUSTRALIA PTY. LTD. www.optibelt.com.au
	OPTIBELT AG www.optibelt.it		OPTIBELT INDONESIAEN www.optibelt.id
	OPTIBELT PHILIPPINEN www.optibelt.ph		OPTIBELT MEXIKO www.optibelt.mx
	OPTIBELT VIETNAM www.optibelt.vn		OPTIBELT THAILAND www.optibelt.th

TABLE OF CONTENTS

PRODUCT DESCRIPTION DRIVE BELTS

optibelt RED POWER 3 High Performance Wedge Belts	6
optibelt BLUE POWER High Performance Wedge Belts	7
optibelt SK High Performance Wedge Belts	8-9
optibelt VB Classic V-Belts	10
optibelt KB Kraftbands	11-14
optibelt SUPER X-POWER M=S – Raw Edge, Moulded Cogged	15-16
optibelt SUPER E-POWER M=S – Raw Edge, Moulded Cogged	17-18
optibelt SUPER TX M =S V-Belts – Raw Edge, Moulded Cogged	19
optibelt VARIO POWER Variable Speed Belts – Raw Edge, Moulded Cogged/Double Cogged	20
optibelt DK Double-Sided V-Belts	21
Standard Properties	22
Special Constructions	23

STANDARD RANGE DRIVE BELTS

optibelt RED POWER 3 High Performance Wedge Belts, Profiles SPZ, SPA, SPB, SPC, 3V/9N, 5V/15N, 8V/25N	24-25
optibelt BLUE POWER High Performance Wedge Belts, Profiles SPB, SPC, 8V/25N	26
optibelt SK High Performance Wedge Belts, Profiles SPZ, SPA, SPB, SPC, 3V/9N, 5V/15N, 8V/25N	27-28
optibelt VB Classic V-Belts, Profiles 5, Y/6, 8, Z/10, A/13, B/17, 20, C/22, 25, D/32, E/40	29-33
optibelt RED POWER 3 Kraftbands, Profiles SPB, SPC, 3V/9J, 5V/15J, 8V/25J	34-35
optibelt BLUE POWER Kraftbands, Profile SPB, SPC, 5V/15J, 8V/25J	36-37
optibelt KB Kraftbands, Profiles SPZ, SPA, SPB, SPC, 3V/9J, 5V/15J, 8V/25J optibelt SUPER KBX-POWER Kraftbands, Profiles 3VX/9JX, 5VX/15JX optibelt KB Kraftbands, Profiles A/HA, B/HB, C/HC, D/HD	38-41
optibelt SUPER X-POWER M=S, Profiles XPZ, XPA, XPB, XPC, 3VX/9NX, 5VX/15NX	42
optibelt SUPER E-POWER M =S V-Belts, Profiles XPZ, XPA, XPB, XPC, 3VX/9NX, 5VX/15NX	43
optibelt SUPER TX M=S V-Belts, Profiles ZX/X10, AX/X13, BX/X17, CX/X22	44
optibelt VARIO POWER Variable Speed Belts	45-46
optibelt DK Double-Sided V-Belts, Profiles AA/HAA, BB/HBB, CC/HCC, DD/HDD, 22 x 22, 25 x 22	47

PRODUCT DESCRIPTION METAL

optibelt KS V-Grooved Pulleys, optibelt TB Taper Bushes	48
optibelt KS V-Grooved Pulleys, Types	49
optibelt KS V-Grooved Pulleys, Standards – Design Criteria – Types	50

STANDARD RANGE METAL

optibelt KS V-Grooved Pulleys for Wedge Belts and for Classic V-Belts	51-52
optibelt KS V-Grooved Pulleys USA Standard for Wedge Belts	53
optibelt KS V-Grooved Pulleys for Kraftbands	54-55
optibelt Deep Grooved Pulleys	56
optibelt KS V-Grooved Pulleys for Taper Bushes	57-65
optibelt KS V-Grooved Pulleys for Cylindrical Bores	66-71
optibelt TB Taper Bushes	72

TABLE OF CONTENTS

DRIVE CALCULATION	Manual Calculation 73-84
	Formulas and Calculation Example 85-87
	Calculation with optibelt CAP 88
POWER RATINGS	optibelt RED POWER 3 89-93
	optibelt BLUE POWER 94-97
	optibelt SK 98-102
	optibelt VB 103-113
	optibelt SUPER X-POWER M=S 114-117
	optibelt SUPER E-POWER M=S 118-121
	optibelt SUPER TX M=S 122-125
SPECIAL DRIVES	V-Flat Drives 126-128
	Tension/Guide Idlers 129-131
	Twist Drives 132-134
	Drive Elements with Aramid Structures 135-136
DESIGN SUPPORT	Belt Tension for OPTIBELT V-Belts and Kraftbands 137-141
	Calculating the Axial Load/Shaft Load 142
	Technical Tools 143-147
	Installation, Maintenance and Storage 149-153
	Properties 154-157
	Problem – Causes – Remedies 158-159
	Length Measurement Conditions and Conversion Factors, Length Tolerances 160-164
	Conversion Factors 165-166
CONVEYOR BELTS	Product Description 167
	Design Guidelines 168
	optibelt KB Kraftbands with Patterned Top Surface 168
	optibelt PKR Endless V-Belts and optibelt KB Kraftbands with Patterned Top Surface 169
	optimat PKR Open-Ended V-Belts DIN 2216 with Patterned Top Surface 170
	optibelt RR Round Belts, optibelt KK Plastic V-Belts and optibelt KK Plastic V-Belts with Patterned Top Surface/Pointed Roof Profile 171
ANNEX	Overview of Standards 172
	Data Sheet for Calculation/Checking of Drives 173-174
	Data Sheet for Calculation/Checking of Conveyor Systems 175-176

PRODUCT DESCRIPTION

optibelt RED POWER 3 HIGH PERFORMANCE WEDGE BELTS

Structure

optibelt RED POWER 3 wedge belts:

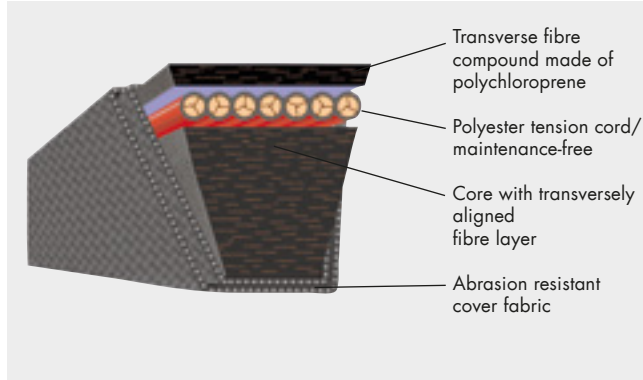

The tension cord consists of a special polyester cord. Due to the special processing of the tension cord the optibelt RED POWER 3 wedge belt is very low-stretch and maintenance-free, so that re-tensioning is not necessary.

The transverse fibre mixture on top of and under the tension cord guarantees a high dynamic load of the belt and ensures great flexibility. The cover fabric is highly flexible and abrasion-proof.

Properties

The optibelt RED POWER 3 is maintenance-free due to the high quality components and the special production method. The production processes are continuously monitored using state-of-the-art static and dynamic testing devices. The optibelt RED POWER 3 is suitable for the application in drives with idler pulleys due to its special construction.

The RED POWER 3 has the following properties:

- Maintenance-free
- Powerful
- Cost-effective
- S=C plus usable in sets
- Environmentally friendly
- Electrically conductive according to ISO 1813
- Oil-resistant
- Heat-resistant
- Dust-protected as standard

On request with acceptance test certificate according to EN 1020 "3.1.B".

V-Belt tensioning

For the initial installation of optibelt RED POWER 3 V-belts, the same methods are used as for standard OPTIBELT V-belts. The tension values are to be calculated on the same basis or to be taken from the table on page 138. Once correctly tensioned optibelt RED POWER 3 V-belts need no re-tensioning.

Application areas

optibelt RED POWER 3 wedge belts were especially developed for mechanical engineering. The application areas include compressors, pumps, presses, fans and other heavy duty drives.

Standardisation/Dimensions

optibelt RED POWER 3 wedge belts in the profiles SPZ, SPA, SPB, SPC, 3V/9N, 5V/15N and 8V/25N are standardised according to DIN 7753 Part 1, ISO 4184 and RMA/MPTA.

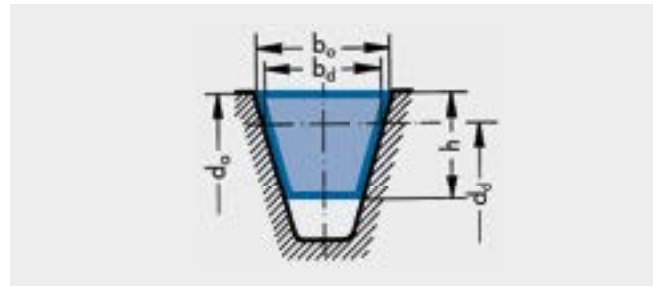

Table 1

Profile		SPZ	SPA	SPB	SPC
Belt top width	$b_o \approx$	9.7	12.7	16.3	22
Datum width	$b_d \approx$	8.5	11	14	19
Belt height	$h \approx$	8	10	13	18
Recommended minimum datum pulley diameter	$d_{d \min}$	63	90	140	224
Weight per meter (kg/m)	\approx	0.074	0.123	0.195	0.377
Flex rate (s^{-1})	$f_{B \max} \approx$	100			
Belt speed (m/s)	$v_{\max} \approx$	55*			

* $v > 55$ m/s. Please consult our Application Engineering Department.

Table 2

Profile		3V/9N	5V/15N	8V/25N
Datum width	$b_o \approx$	9	15	25
Belt height	$h \approx$	8	13	23
Recommended minimum outside pulley diameter	$d_{a \min}$	67	151	315
Weight per meter (kg/m)	\approx	0.074	0.195	0.575
Flex rate (s^{-1})	$f_{B \max} \approx$	100		
Belt speed (m/s)	$v_{\max} \approx$	55*		

* $v > 55$ m/s. Please consult our Application Engineering Department.

PRODUCT DESCRIPTION

optibelt **BLUE POWER** HIGH PERFORMANCE WEDGE BELTS

Structure/Properties

optibelt BLUE POWER wedge belts:

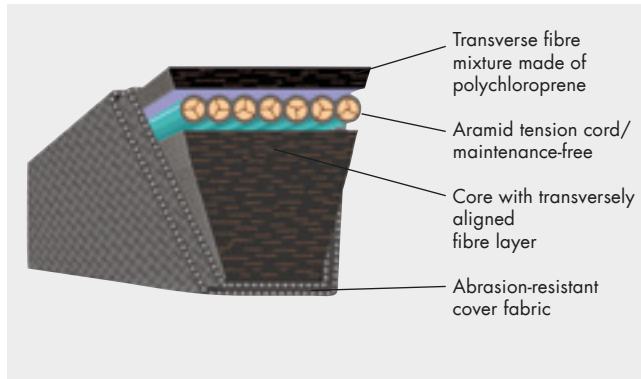

The aramid tension cord has extremely low-stretch compared to common materials such as polyester. The breaking strength is almost twice as high with the same cord diameter. Nevertheless, the fibre is extremely flexible. The high quality specially prepared aramid tension cord is embedded in a rubber compound. It is supported by the top and bottom structures. These consist of a polychloroprene rubber compound with transverse fibres. The abrasion-proof cover fabric is coated with a special rubber compound and covers the whole belt. The V-belt is electrically conductive according to ISO 1813

optibelt BLUE POWER belts are mainly used when

- highest power transmission levels are required
- there are limited design dimensions
- there is only little installation and tensioning space
- high temperature influences occur

This way, a much better performance is guaranteed e. g. with the same number of belts. Even the operation of once critical drives is now largely free of risk. Higher load limits are now safety zones. Thus optibelt BLUE POWER belts are mainly implemented in heavily loaded drives:

- in critical drives in mechanical engineering
- in special machines
- in agricultural machinery

Application

Attention: When retro-fitting existing drives please let OPTIBELT check the tension. As part of this description not all criteria can be dealt with. Please consult our Application Engineering Department.

Standardisation/Dimensions

optibelt BLUE POWER wedge belts in the profiles SPZ, SPA, SPB, SPC, 3V/9N, 5V/15N and 8V/25N are standardised according to DIN 7753 Part 1, ISO 4184 and RMA/MPTA.

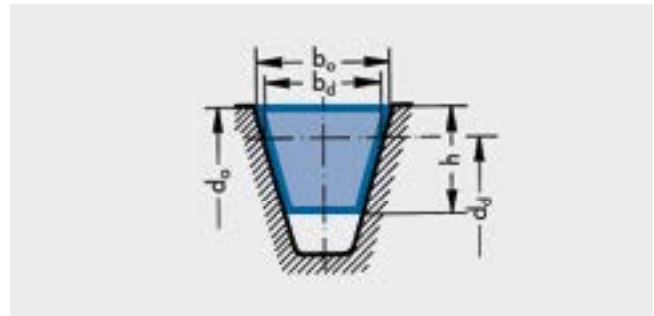

Table 3

Profile		SPB	SPC
Belt top width	$b_o \approx$	16.3	22
Datum width	$b_d \approx$	14	19
Belt height	$h \approx$	13	18
Distance	$h_d \approx$	3.5	4.8
Recommended minimum datum pulley diameter	$d_{d \min}$	180	280
Weight per meter (kg/m)	\approx	0.206	0.389
Flex rate (s^{-1})	$f_{B \max} \approx$	100	
Belt speed (m/s)	$v_{\max} \approx$	50*	

* $v > 50$ m/s. Please consult our Application Engineering Department.

Table 4

Profile		5V/15N	8V/25N
Datum width	$b_o \approx$	15	25
Belt height	$h \approx$	13	23
Recommended minimum outside pulley diameter	$d_{a \min}$	191	315
Weight per meter (kg/m)	\approx	0.204	0.603
Flex rate (s^{-1})	$f_{B \max} \approx$	100	
Belt speed (m/s)	$v_{\max} \approx$	50*	

* $v > 50$ m/s. Please consult our Application Engineering Department.

PRODUCT DESCRIPTION

optibelt SK HIGH PERFORMANCE WEDGE BELTS

DIN 7753 PART 1 / ISO 4184

Structure

optibelt SK wedge belts consist of:

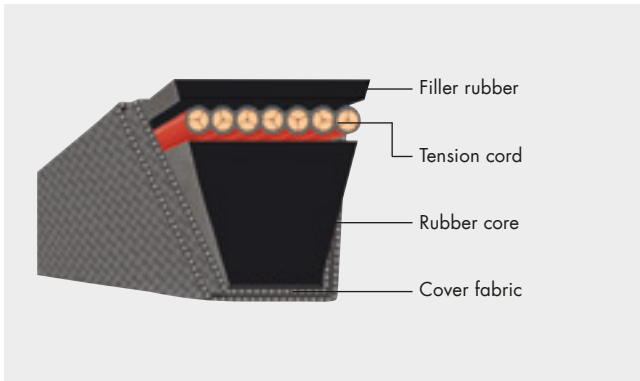

The polyester tension cord is standard for all profiles and cross sections, with cord constructions matching the requirements of each profile. The cord is specially impregnated and then embedded in a special rubber compound homogeneously bonding with the base and the core.

Due to special processing, the optibelt SK wedge belt is extremely low-stretch. Thus we were able to reduce our recommendation values for minimum axial distance significantly – even dropping below the DIN/ISO requirements. The fabric cover is treated with a wear-resistant rubber compound. This makes the belt resistant to oil, hot and cold temperatures and to the effects of dust.

Properties

The use of the best materials and the most advanced production methods result in this high performance drive element, the optibelt SK wedge belt. The production processes are continuously monitored using state-of-the-art static and dynamic testing devices.

optibelt SK high power wedge belts exceed classic V-belts according to DIN 2215 thanks to the following characteristics:

- Substantially lower width compared to classic V-belt drives that have the same power rating (height to width ratio of approximately 1:1.2). Due to the available space gained by this, the costs for a complete drive with optibelt SK high performance wedge belts are lower than a design with DIN 2215 V-belts.
- Bigger friction surface lowers the centrifugal force and permits belt speeds of up to 42 m/sec.
- Much more elastic, therefore bigger flex rate allowed.
- Little deformation of the belt cross-section when running in grooves, therefore balanced pressure on the belt edges.

These characteristics allow for a significantly better performance than V-belts DIN 2212 with approximately the same top widths. Therefore, we recommend equipping all new drives with optibelt SK wedge belts.

Applications

optibelt SK wedge belts in the profiles SPZ, SPA, SPB and SPC were specially developed for all industrial applications from lightly loaded drives, such as those for pumps, up to heavily loaded mills and even stone crusher drives.

Standardisation/Dimensions

optibelt SK wedge belts SPZ, SPA, SPB and SPC comply with the standards of DIN 7753 and ISO 4184.

The ISO standards specify the datum width as a basis for the standardisation of V-belts and grooves.

The staggering of the datum lengths is implemented according to DIN 7753 Part 1 corresponding to the standard number sequence R 40. In exceptional cases also corresponding to standard number sequence R 20.

For many years, our product range has comprised serial production datum lengths of standard number sequence R 40 and beyond.

Note: Electrically conductive according to ISO 1813.

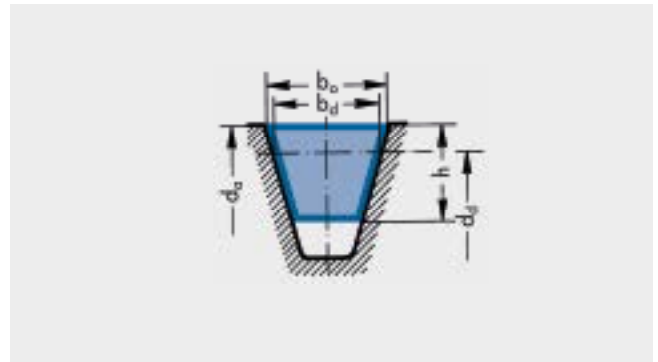

Table 5

Profile		SPZ	SPA	SPB	SPC
Belt top width	$b_o \approx$	9.7	12.7	16.3	22
Datum width	$b_d \approx$	8.5	11	14	19
Belt height	$h \approx$	8	10	13	18
Recommended minimum datum pulley diameter	d_{dmin}	63	90	140	224
Weight per meter (kg/m)	\approx	0.074	0.123	0.195	0.377
Flex rate (s ⁻¹)	$f_{Bmax} \approx$		100		
Belt speed (m/s)	$v_{max} \approx$		42*		

* $v > 42$ m/s. Please consult our Application Engineering Department.

PRODUCT DESCRIPTION

optibelt SK WEDGE BELTS

USA STANDARD RMA/MPTA

Structure/Properties

optibelt SK wedge belts according to USA standard RMA/MPTA have the same structure and properties as wedge belts according to DIN 7753 Part 1.

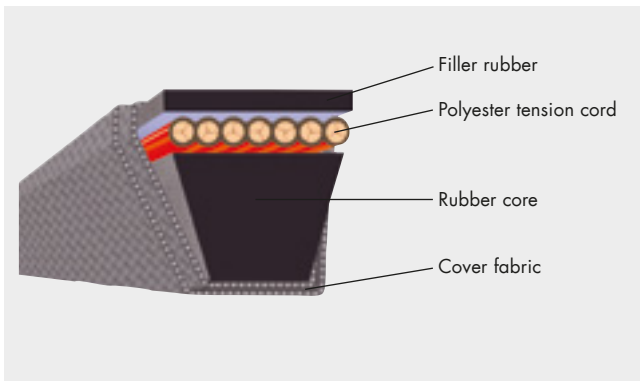

Standardisation/Dimensions

The three wedge belt profiles standardised in the USA are 3V/9N, 5V/15N and 8V/25N. The cross section dimensions of these belts and the according length only partially conform to the profiles and lengths of the wedge belts DIN 7753 Part 1.

The profile 3V/9N roughly corresponds to SPZ; and 5V/15N to profile SPB. There is no comparable DIN/ISO wedge belt profile for 8V/25N. It is possible to use belts in profile 3V/9N and 5V/15N in SPZ-Z/10 or SPB-B/17 pulleys, respectively; but the use of SPZ or SPB belts in RMA/MPTA standard pulleys is not generally recommended. The top width of the American pulley grooves is smaller than that of the corresponding DIN/ ISO pulleys. This can cause wear on the upper edges of SPZ and SPB belts and can lead to premature failure.

Due to its cross section, the optibelt SK wedge belt in SPB profile is also suitable for 5V/15N pulleys.

Note: Electrically conductive according to ISO 1813.

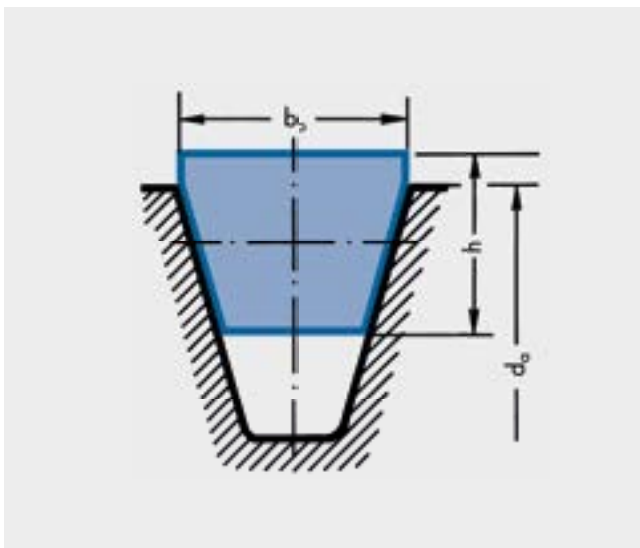

Table 6

Profile		3V/9N	5V/15N	8V/25N
Belt top width	$b_o \approx$	9	15	25
Belt height	$h \approx$	8	13	23
Recommended minimum pulley outside diameter	$d_{a\min}$	67	151	315
Belt weight (kg/m)	\approx	0.074	0.195	0.575
Flex rate (s^{-1})	$f_{B\max} \approx$	100		
Belt speed (m/s)	$v_{\max} \approx$	55*		

* > 55 m/s. Please contact our Application Engineering Department.

The belt length designation refers to the effective outside length.

Example:

Inch designation	Metric designation
3V 750	9N 1905
3V = profile 3/8"	9 \approx 9 mm
750 = outside length in inches : 10 (1 inch = 25.4 mm)	N = designation for single V-belt
Outside length in mm:	1905 = effective outside length

$$L_a = \frac{750 \cdot 25.4}{10}$$

$$L_a = 1905 \text{ mm}$$

Applications

The use of optibelt SK wedge belt drives in profiles 3V/9N and 5V/15N is recommended for machines exported to countries such as the USA and Canada where these belt profiles are standardised and predominantly used. Profile 8V/25N is primarily employed in very heavy duty drives such as mills or stone crushers. As these wedge belts transmit very high levels of power, they can sometimes form a more compact drive than the SPC profile.

For this reason, the 8V/25N profile has continued to be used in Europe for such applications. A further advantage is the fact that single wedge belts can be replaced by kraft-bands, without changing the pulley geometry, in case unexpected belt vibration problems develop.

Drive calculation

Drive calculations follow the procedures described in this manual. The power value of the SPZ applies for drives with the 3V/9N profile. The value of the SPB profile applies for 5V/15N. The datum diameters of the SPZ and SPB wedge belts have to be the same as the external diameters of the 3V/9N and 5V/15N. Slight mathematical differences in the rotational frequency and transmission have no practical influence. Slight differences in the theoretical drive speed and the speed ratio are not significant in practice.

PRODUCT DESCRIPTION

optibelt **VB** CLASSIC V-BELTS

DIN 2215 / ISO 4184

Structure/Properties

optibelt VB classic V-belts are manufactured using the same production processes as those for optibelt SK high performance wedge belts.

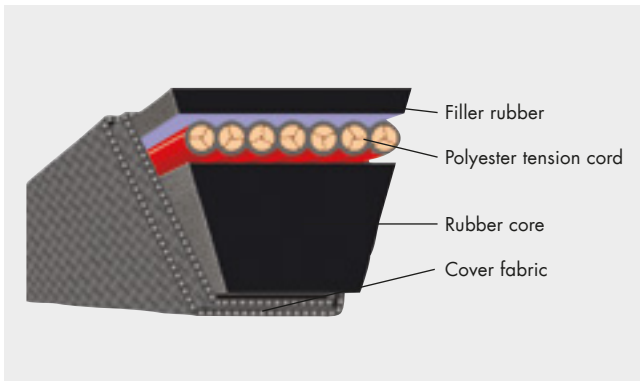

The components used are perfectly suited to the power ratings P_N . These values are far above those given by DIN 2218. Thus the operational safety in existing drives is increased and overloading is avoided.

- optibelt VB classic V-belts have a height-width ratio of 1:1.6.
- The maximum belt speed $v_{\max} = 30$ m/s should not be exceeded.
- The allowed flexibility rate is far below that of wedge belts. It is $f_{B \max} = 80$ s⁻¹.

Application areas

optibelt VB classic V-belts are mainly employed as replacement parts for industrial drives. For new drives, the use of high performance wedge belts is almost always recommended due to reasons of space and cost. However, special drives such as V-flat drives can often only be operated with classic V-belts. In special constructions, optibelt VB classic V-belts tackle difficult drives in the gardening sector and in agricultural machinery.

For these applications special belt constructions and calculation methods are required which are not included in this manual. In these cases we ask you to give us the according drive data.

Standardisation/Dimensions

optibelt VB classic V-belts in the profiles Y/6, Z/10, A/13, B/17, C/22, D/32 and E/40 are standardised according to DIN 2215 and ISO 4184.

Further, non-standardised ISO profiles 5, 8, 20 and 25 are available. These profiles should however not be used due to reasons of exchangeability and rationalisation.

The ISO standard 4184 specifies the datum length for measuring the belt length. The former belt designation of the inside length L_i is replaced by the datum length L_d . For the conversion factors from pitch to inside length, please see page 161.

Note: Electrically conductive according to ISO 1813.

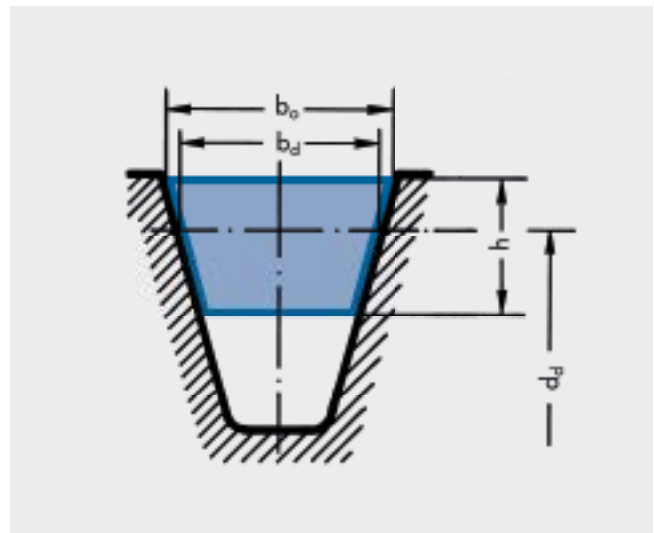

Table 7

Profile	DIN 2215	(5)	6	(8)	10	13	17	(20)	22	(25)	32	40
	ISO 4184	-	Y	-	Z	A	B	-	C	-	D	E
Belt top width	$b_o \approx$	5	6	8	10	13	17	20	22	25	32	40
Datum width	b_d	4.2	5.3	6.7	8.5	11	14	17	19	21	27	32
Belt height	$h \approx$	3	4	5	6	8	11	12.5	14	16	20	25
Recommended minimum pulley outside diameter	$d_{d \min}$	20	28	40	50	75	125	160	200	250	355	500
Belt weight (kg/m)	\approx	0.018	0.026	0.042	0.064	0.109	0.190	0.266	0.324	0.420	0.690	0.958
Flex rate (s ⁻¹)	$f_{B \max} \approx$						80					
Belt speed (m/s)	$v_{\max} \approx$						30					

PRODUCT DESCRIPTION

optibelt **KB** KRAFTBANDS

Product characteristics

optibelt KB kraftbands are characterised by the following properties:

- High level of uniform power transmission
- Favourable running behaviour especially regarding vibration
- Excellent flexibility
- High centre distances with small pulley datum diameters
- V-flat drives
- Vertical drives
- Clutched drives and conveyance drives

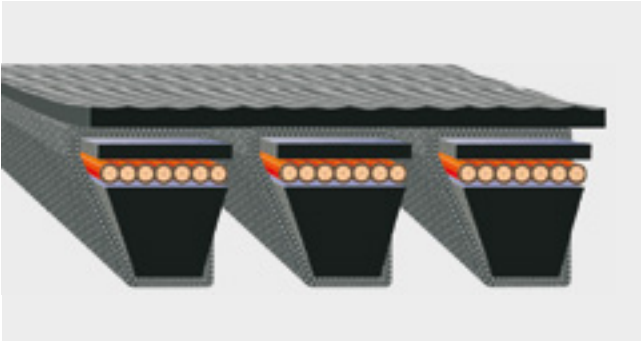

optibelt KB kraftbands consist of individual V-belts that are connected to one another via a top surface. Depending on the application the kraftbands will be fitted with two, three, four or five ribs.

On special request, kraftbands can also be delivered with more than five ribs.

When using multiple kraftbands per drive, combinations of sets are required.

Order example

The drive is to be equipped with a 5V 1600/15J 4064 kraftband with 18 ribs.

Kraftbands: Installation combination with 5/4/4/5 ribs

The order is as follows:

A KB set, consisting of:

2 pieces optibelt KB kraftbands 4-5V 1600/15J 4064 and

2 pieces optibelt KB kraftbands 5-5V 1600/15J 4064

4 or 5 = quantity of ribs

5V/15J = profile

1600 = belt number or 160 inch belt length

4064 = outside length in mm

Standardisation/Dimensions

KB wedge belts

optibelt KB kraftbands with high power wedge belts are manufactured in SPZ, SPA, SPB, SPC profiles as well as in 3V/9J, 5V/15J, 8V/25J in compliance with international conventions.

SPZ, SPA, SPB and SPC kraftbands can be used with V-grooved pulleys according to DIN 2211 and ISO 4183. 3V/9J, 5V/15J, 8V/25J kraftbands can be used with V-grooved pulleys according to ISO 5290 and USA standard RMA/MPTA IP 22.

KB classic V-belts

optibelt KB kraftbands with classic V-belts are manufactured in AJ/HA, BJ/HB, CJ/HC, DJ/HD profiles in compliance with international conventions.

The ISO 5291 standard and the RMA/MPTA IP 20 USA standard are applied to kraftbands in machine construction. The ASAE S211. ... USA standard is applied to kraftbands used in agricultural machine construction.

Note: Electrically conductive according to ISO 1813.

PRODUCT DESCRIPTION

optibelt **KB** KRAFTBANDS

Product design

The optibelt KB kraftbands are used in the most varied constructions according to the technical requirements and applications.

Wrapped kraftbands

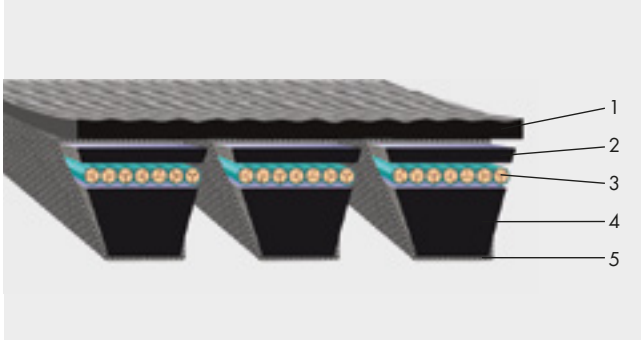

- 1 Top surface
- 2 Rubber coating
- 3 Polyester tension cord
- 4 Base compound
- 5 Cover fabric

Profiles

3V/9J; 5V/15J; 8V/25J;
SPZ; SPA; SPB; SPC;
A/HA; B/HB; C/HC; D/HD

Dimensions

1200 mm to 12,000 mm
standard range

Application areas:

OPTIBELT wrapped KB kraftbands are primarily used in mechanical engineering and agricultural machines.

RED POWER 3 high performance kraftbands – wrapped

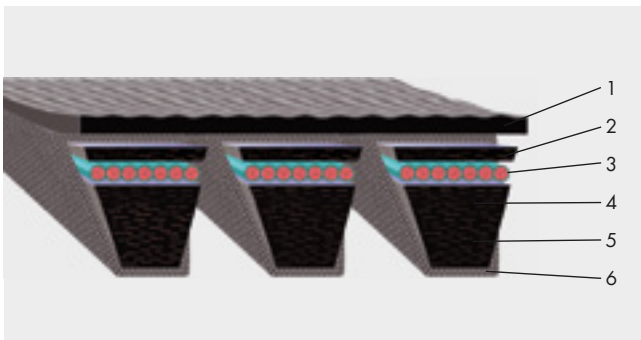

- 1 Top surface
- 2 Transverse polychloroprene fibre compound
- 3 Polyester tension cord, maintenance-free
- 4 Transverse polychloroprene fibre compound
- 5 Base compound
- 6 Abrasion-resistant cover fabric

Profiles

3V/9J; 5V/15J; 8V/25J;
SPB; SPC

Dimensions

1200 to 12,000 mm
standard range

Application areas

This compact drive element is primarily used for special problem solutions in mechanical engineering and commercial vehicle construction.

We recommend the use of optibelt KB RED POWER 3 for maintenance-free drives and for the use with back bend tension idlers.

PRODUCT DESCRIPTION

optibelt **KB** KRAFTBANDS

High performance kraftbands – raw edge SUPER KBX-POWER

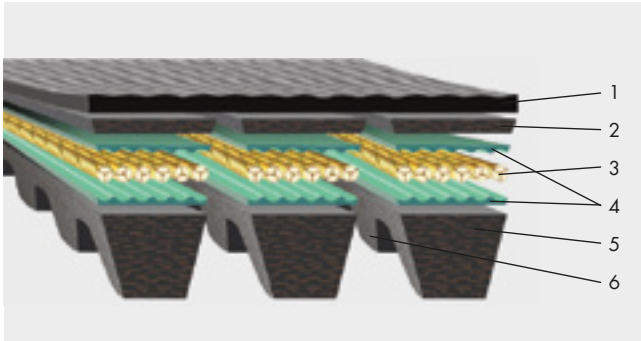

- 1 Top surface
- 2 Upper belt structure
- 3 Polyester tension cord, low maintenance
- 4 Embedding compound
- 5 Belt base
- 6 Moulded cogs

Profiles

3VX/9JX; 5VX/15JX;
XPB
XPZ; XPA on request

Dimensions

1270 mm to 3556 mm
standard range

Application areas

The use of SUPER KBX-POWER kraftbands is recommended when dealing with compact drive solutions with high power requirements, small pulley datum diameters and for many more special applications in mechanical engineering and vehicle construction.

Kraftbands with aramid cord – wrapped and raw edge

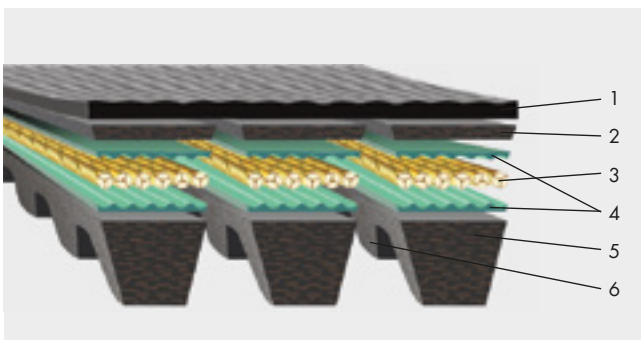

- 1 Top surface
- 2 Upper belt structure
- 3 Aramid tension cord, low maintenance
- 4 Embedding compound
- 5 Belt base
- 6 Moulded cogs

Profiles

3V/9J; 5V/15J; 8V/25J;
SPB; SPC; 5VX/15JX;
A/HA; B/HB; C/HC

Dimensions

1270 mm up to 12,000 mm wrapped kraftbands
1270 mm up to 3556 mm raw edge kraftbands
standard range

Application areas

The advantages of the optibelt KB kraftbands with aramid tension cords become obvious when dealing with heavy loaded drives in mechanical engineering and in the agricultural machine industry. These kraftbands provide the highest possible level of reliability wherever high temperature impacts and low adjustment ranges are present.

PRODUCT DESCRIPTION

optibelt **KB** KRAFTBANDS

Kraftbands with top coatings

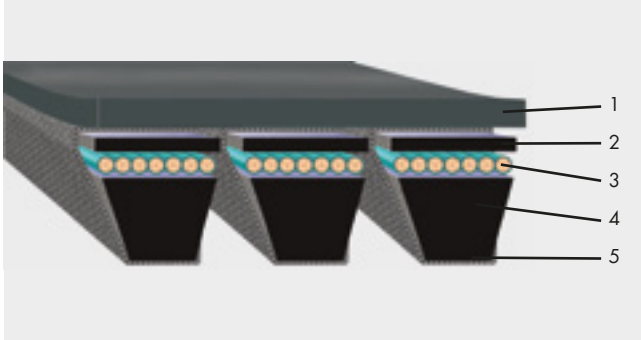

- 1 PKR top surface
- 2 Rubber coating
- 3 Polyester tension cord
- 4 Rubber core
- 5 Cover fabric

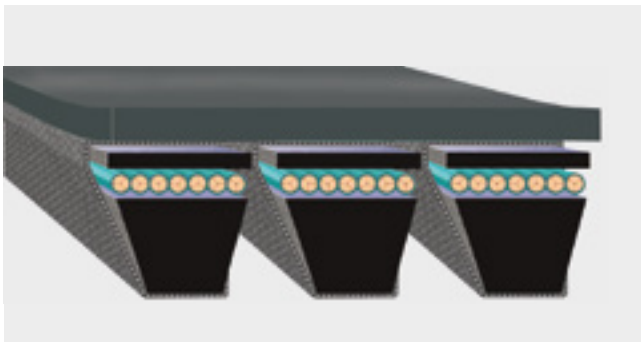

Kraftband
with PKR 0 coating

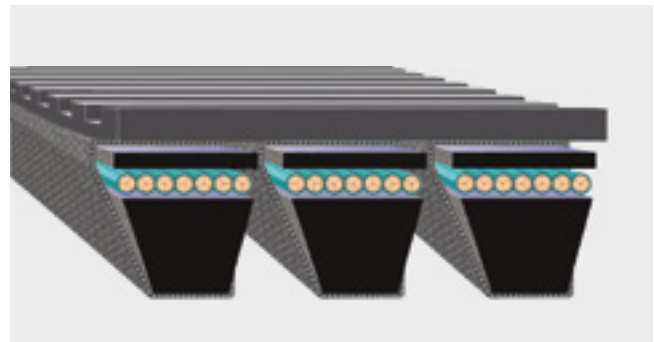

Kraftband
with PKR 1 coating

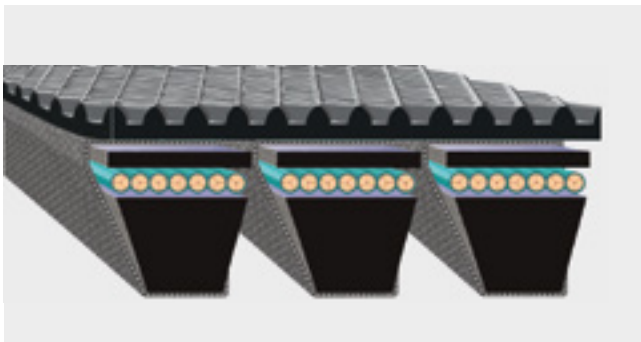

Kraftband
with PKR 2 coating

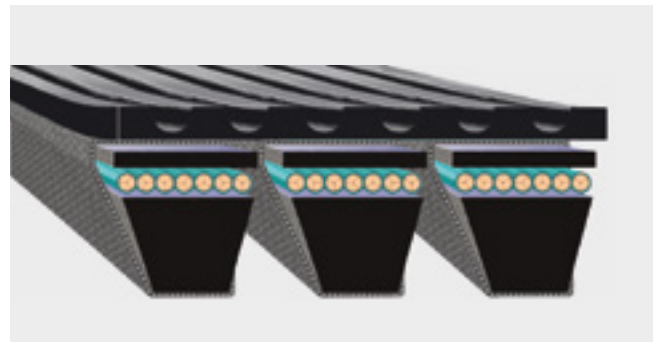

Kraftband
with PKR 3 coating

Application areas

When dealing with conveyance applications, the optibelt KB kraftbands can be provided with an additional coating.

With patterned top surfaces, these kraftbands are suitable for the conveyance of containers, heavy cargo and for diverse transport and shipment equipment.

Further details see chapter "Conveyor elements".

Drive calculation

Drives with optibelt KB kraftbands in mechanical engineering have to be designed according to the stated drive calculation example found on pages 85 to 87 in this manual as well as according to the power values for the according products and profiles.

Special power and tension values apply for OPTIBELT kraftbands with aramid constructions. Agricultural machine drives will be dimensioned according to special calculation methods. Therefore we request the submission of the technical data.

PRODUCT DESCRIPTION

optibelt **SUPER X-POWER M=S**

RAW EDGE, MOULDED COGGED – DIN/ISO, RMA/MPTA

Advantages

SUPER X-POWER M=S wedge belts are perfectly suited for applications with

- extremely small pulley diameters
- high rotational speeds
- high and low ambient temperatures

SUPER X-POWER M=S wedge belts offer

- high power transmission
- extremely low stretch
- improved maintenance intervals – low maintenance
- optimised running characteristics – smooth running
- excellent heat and oil resistance
- M=S, for set matching
- electrically conductive according to ISO 1813

Drive ratios $i = 1:12$ are possible with optibelt SUPER X-POWER.

Multi-stage drives can be eliminated.

optibelt SUPER X-POWER M=S wedge belts in profiles XPZ, XPA, XPB, XPC, 3VX/9NX and 5VX/15NX, offer the best technical and economic solutions due to their harmonised premium materials.

Structure/Properties

optibelt SUPER X-POWER M=S consist of:

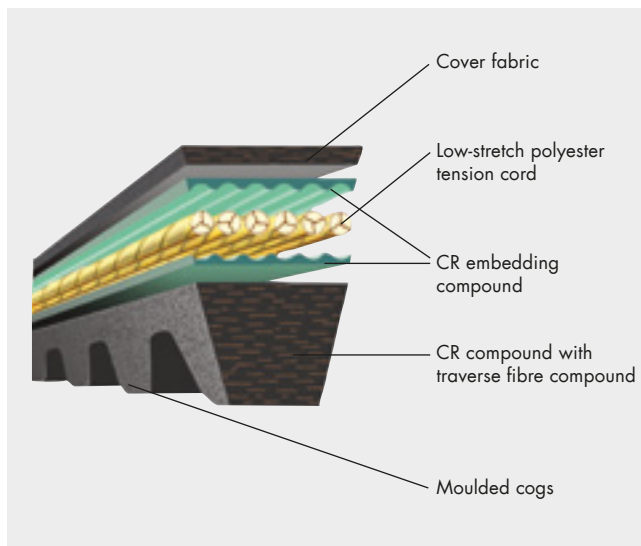

1. The special polyester tension cord of SUPER X-POWER M=S is extremely low-stretch and allows for maintenance-free drives.

The number of re-tensioning processes is reduced and the drive becomes less expensive in the long term.

2. The structure of the cover fabric supports the tension cord and this is how the SUPER X-POWER M=S achieves its high level of flexibility.

3. The belt base structure consists of a high performance chloroprene compound, reinforced with a traverse fibre compound.

The special tension cord and the optimum tooth shape allow for higher dynamic power transmissions, improved bending stress and a higher temperature resistance.

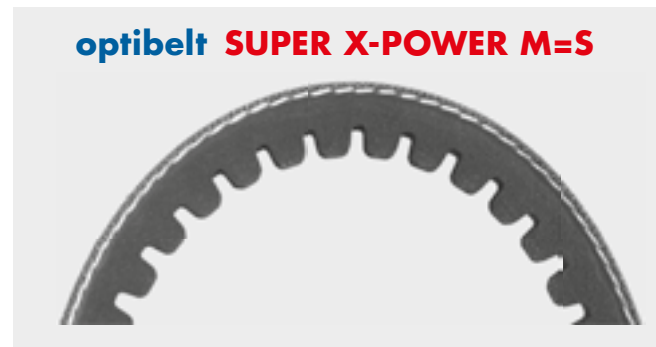

As high power transmission is possible, even with small pulley diameters and high engine speed, weight and space can be reduced thus also substantially reducing costs.

Application areas Machines:

- compressors
- fans
- compactors
- pumps
- wood working machines
- high performance saws
- special machines

Machine tools:

- lathes and drilling machines
- grinding machines

optibelt SUPER X-POWER M=S V-belts are recommended for mechanical engineering applications wherever wrapped V-belts are likely to reach their performance limits.

PRODUCT DESCRIPTION

optibelt **SUPER X-POWER M=S**

RAW EDGE, MOULDED COGGED – DIN/ISO, RMA/MPTA

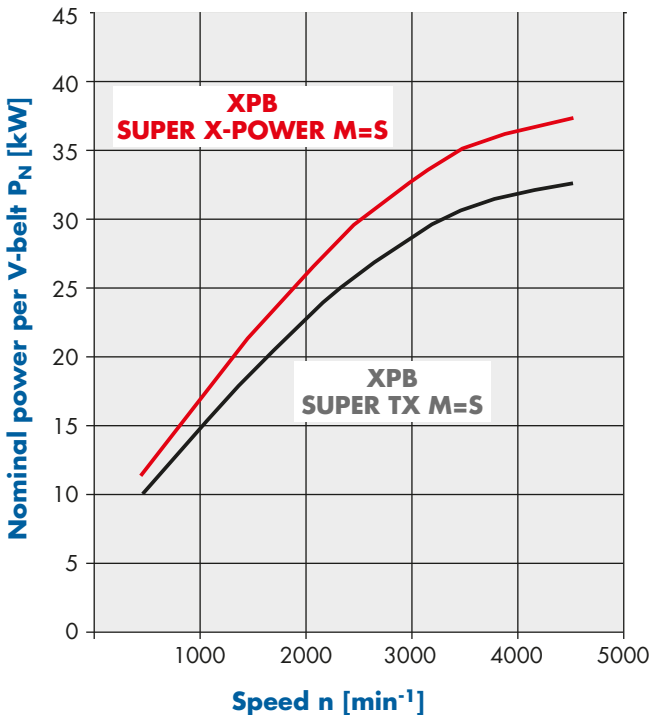

Belt tension / Static shaft load

Belt tension and static shaft load are calculated in the same way as for wrapped belts. When dealing with the same geometric ratios, the shaft load does not exceed that of wrapped belts although the quantity of the belts is often less. Therefore, only the individual V-belt requires higher tension than wrapped belts.

The precise edges of the optibelt SUPER X-POWER M=S V-belt ensure uniform seating in the pulley grooves, resulting in smoother running.

Drive calculation

Drive design using optibelt SUPER X-POWER M=S belts should be carried out according to the examples given on pages 85 to 87. The higher power ratings given in the relevant tables, apply. These are based on a theoretical laboratory running time of 25,000 hours.

Standardisation/Dimensions

The cross sections and dimensions of optibelt SUPER X-POWER M=S V-belts are in accordance with DIN 7753 Part 1, DIN 2215, ISO 4184 and RMA/MPTA.

The basis for the length measurement is the datum length (L_d) to DIN/ISO.

Table 8

Profile	Top belt width $b_o \approx$	Datum width b_d	Belt height $h \approx$	Meter weight [kg/m] \approx
XPZ	9.7	8.5	8	0.065
XPA	12.7	11.0	10	0.105
XPB	16.3	14.0	13	0.183
XPC	22.0	19.0	18	0.340
3VX/9NX	9.0	—	8	0.065
5VX/15NX	15.0	—	13	0.183

V-grooved pulleys

optibelt SUPER X-POWER M=S are used with pulleys according to DIN 2211, DIN 2217, ISO 4183 and RMA/MPTA. Considerably smaller minimum pulley datum diameters are allowed.

Table 9

Recommended minimum pulley diameter [mm] wedge belt			
Profile	Raw edge, moulded cogged	Profile	Wrapped
XPZ	56	SPZ	63
XPA	71	SPA	90
XPB	112	SPB	140
XPC	180	SPC	224
3VX/9NX	56	3V/9N	67
5VX/15NX	112	5V/15N	151

PRODUCT DESCRIPTION

optibelt **SUPER E-POWER M=S**

RAW EDGE, MOULDED COGGED – DIN/ISO, RMA/MPTA

Advantages

SUPER E-POWER M=S wedge belts are perfectly suited for complex applications which require the highest capacities under the most severe conditions such as with

- extremely small pulley diameters
- high rotational speeds
- high and low ambient temperatures

SUPER E-POWER M=S wedge belts offer

- high power transmission, up to 20 % better performance
- extremely high capacity and extremely low stretch
- optimised extremely smooth running characteristics
- optimised operational life and operating times
- improved maintenance intervals and low service expenditures (low maintenance)
- excellent temperature resistance from -50 °C to +120 °C
- M=S, for set matching
- electrically conductive according to ISO 1813 and compatible with ATEX

Structure/Properties

optibelt SUPER E-POWER M=S consist of:

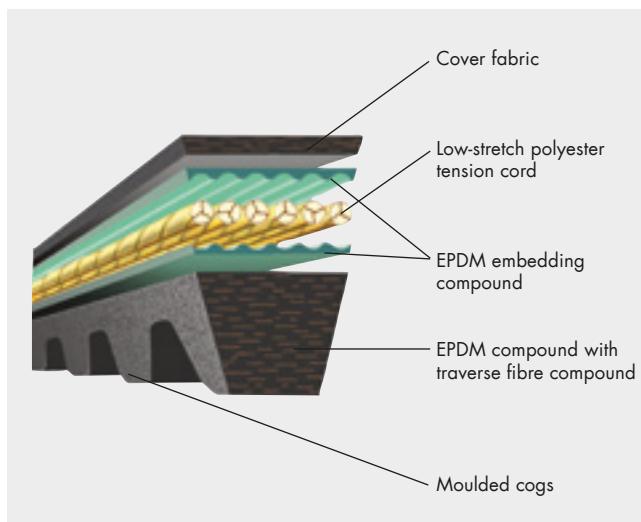

1. The highly modular polyester tension cord of the SUPER E-POWER M=S is very low-stretch and thus allows for a low maintenance drive. The number of re-tensionings is reduced; the drive is more cost-effective in the long term.

2. The structure of the cover fabric supports the tension cord and this is how the SUPER E-POWER M=S achieves its high level of flexibility.

3. The belt base structure consists of a high performance EPDM compound, reinforced with a traverse fibre compound. The special tension cord and the optimised rubber compound allow for a higher power transmission level, less flexing stress and better heat dissipation.

optibelt **SUPER E-POWER M=S**



The use of the SUPER E-POWER M=S by OPTIBELT allows for high power transmissions even with small pulley diameters and high engine speed. Thus, weight and space can be reduced, also additionally reducing costs.

Application areas Machines:

- compressors
- fans
- compactors
- pumps
- wood working machines
- high performance saws
- special machines

Machine tools:

- lathes and drilling machines
- grinding machines

In mechanical engineering, wrapped V-belts are often employed in fringe areas and might wear out soon. In order to prevent downtimes, we recommend using optibelt SUPER E-POWER M=S.

SUPER E-POWER
available on request

PRODUCT DESCRIPTION

optibelt **SUPER E-POWER M=S**

RAW EDGE, MOULDED COGGED – DIN/ISO, RMA/MPTA

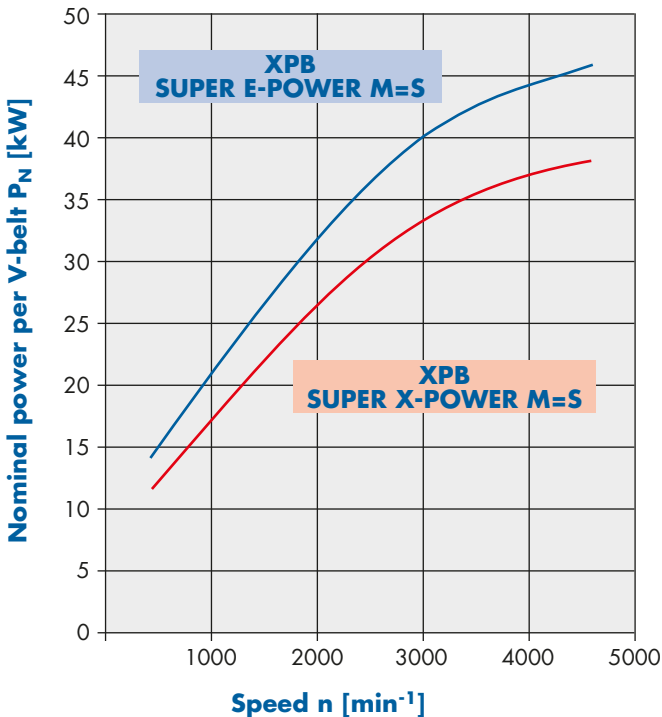

Belt tension / Static shaft load

Belt tension and static shaft load are calculated the same way as for wrapped belts. When dealing with the same geometric ratios, the shaft load does not exceed that of wrapped belts although the quantity of the belts is often less. Therefore, only the individual V-belt requires higher tension than wrapped belts.

The precise edges of the optibelt SUPER E-POWER M=S V-belt ensure uniform seating in the pulley grooves, resulting in smoother running.

Test results

optibelt SUPER E-POWER M=S exhibit a considerably improved tension retention when compared to the common raw edge, moulded cogged construction.

Comparison test: **Tension retention [N]**,

Power P = 13.0 kW, n₁ = 4700 min⁻¹

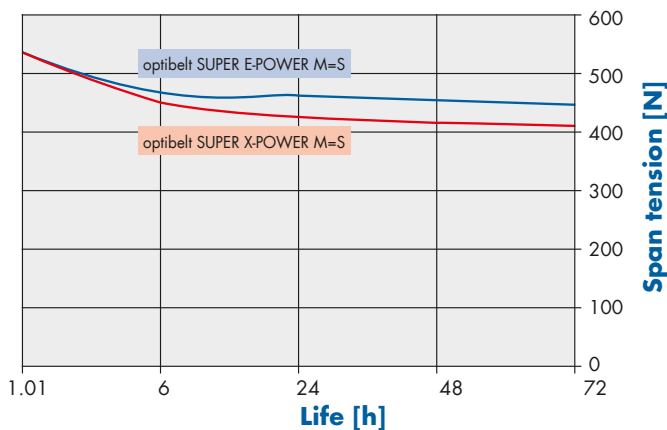

Drive calculation

Drive design using optibelt SUPER E-POWER M=S belts should be carried out according to the examples given on pages 85 to 87. The higher power ratings given in the relevant tables, apply. These are based on a theoretical laboratory running time of 25,000 hours.

Standardisation/Dimensions

The cross sections and dimensions of optibelt SUPER E-POWER M=S V-belts are in accordance with DIN 7753 Part 1, DIN 2215, ISO 4184 and RMA/MPTA.

The basis for the length measurement is the datum length (L_d) to DIN/ISO.

Table 10

Profile	Top belt width b _o ≈	Datum width b _d	Belt height h ≈	Meter weight [kg/m] ≈
XPZ	9.7	8.5	8	0.065
XPA	12.7	11.0	10	0.105
XPB	16.3	14.0	13	0.183
XPC	22.0	19.0	18	0.340
3VX/9NX	9.0	—	8	0.065
5VX/15NX	15.0	—	13	0.183

V-grooved pulleys

optibelt SUPER E-POWER M=S are used with pulleys to DIN 2211, DIN 2217, ISO 4183 and RMA/MPTA.

Considerably smaller minimum pulley datum diameters are allowed.

Table 11

Recommended minimum pulley diameter [mm] wedge belt			
Profile	Raw edge, moulded cogged	Profile	Wrapped
XPZ	56	SPZ	63
XPA	71	SPA	90
XPB	112	SPB	140
XPC	180	SPC	224
3VX/9NX	56	3V/9N	67
5VX/15NX	112	5V/15N	151

PRODUCT DESCRIPTION

optibelt **SUPER TX M=S** V-BELTS

RAW EDGE, MOULDED COGGED – DIN/ISO, RMA/MPTA

The advantages of optibelt SUPER TX M=S V-belts can best be seen when dealing with

- extremely small pulley diameters
- high rotational speeds
- extremely high power requirements
- higher ambient temperatures

In these cases the use of wrapped V-belts is uneconomic and not recommended.

optibelt SUPER TX M=S V-belts in profiles ZX/X10, AX/X13, BX/X17 and CX/X22 offer the best technical and economic solutions under these conditions due to their high quality perfectly harmonised materials.

Structure/Properties

optibelt SUPER TX M=S consist of:

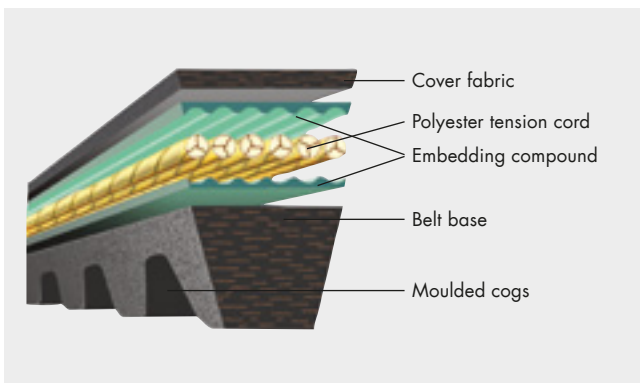

The belt base consists of a polychloroprene rubber compound with traverse fibres which support the tension cord.

This results in

- significant flexing rate
- extreme traverse stability
- significantly improved wear resistance and slip resistance
- electrically conductive according to DIN 1813
- low stretch

The specially prepared tension cord is embedded in a special compound. Even with high dynamic loads a perfect adhesion between all components is assured. The fabric layers of the upper structure support the tension cord. The fibre-reinforced substructure combined with the OPTIBELT tension cord and the moulded cogs allows for a higher dynamic power transmission. The moulded cogs decrease the flexing resistance, resulting in an excellent flexing rate. Thus, much smaller pulleys can be used compared to common wrapped V-belts.

optibelt SUPER TX M=S allows for drive ratios $i = 1:12$. Multi-stage drives can be eliminated.

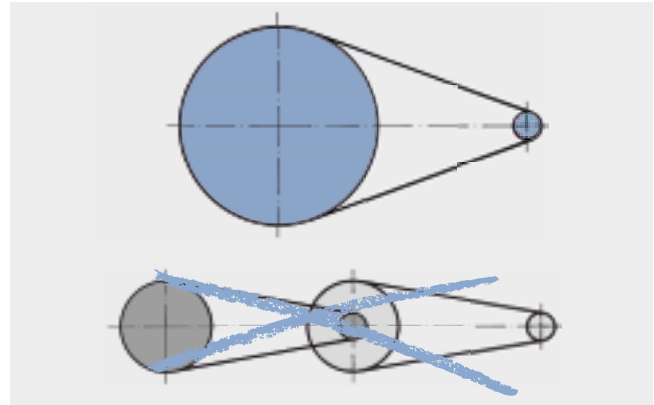

Due to the use of high quality polychloroprene rubber compounds, the optibelt SUPER TX M=S has a higher oil and heat-resistance than wrapped V-belts.

As high power transmission is possible, even with small pulley diameters and high engine speed, weight and space can be reduced thus also substantially reducing costs.

Drive calculation

Drive design using optibelt SUPER E-POWER M=S belts should be carried out according to the examples given on pages 85 to 87. The higher power ratings given in the relevant tables, apply. These are based on a theoretical laboratory running time of 25,000 hours.

V-grooved pulleys

optibelt SUPER TX M=S are used with pulleys to DIN 2211, DIN 2217, ISO 4183 and RMA/MPTA. Considerably smaller minimum pulley datum diameters are allowed.

Table 12

Recommended minimum pulley diameter [mm] V-belts			
Profile	Raw edge, moulded cogged	Profile	Wrapped
ZX/X10	40	Z/10	50
AX/X13	63	A/13	71
BX/X17	90	B/17	112
CX/X22	140	C/22	180

Profile	Top belt width $b_o \approx$	Datum width b_d	Belt height $h \approx$	Meter weight [kg/m] \approx
ZX/X10	10	8.5	6	0.062
AX/X13	13	11	8	0.099
BX/X17	17	14	11	0.165
CX/X22	22	19	14	0.276

PRODUCT DESCRIPTION

optibelt **VARIO POWER** VARIABLE SPEED BELTS

RAW EDGE, MOULDED COGGED / DOUBLE-COGGED – DIN 7719 / ISO 1604

optibelt **VARIO POWER** variable speed belts – raw edge, moulded cogged

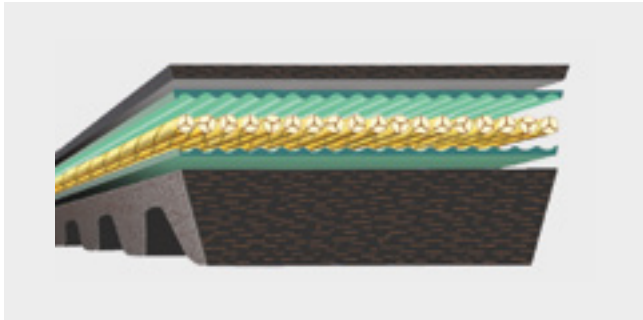

Increasing demands on variable speed belts due to the continuous increase of power transmission levels initiated the development of the raw edge, moulded cogged variable speed belts.

The base compound consists of a polychloroprene rubber compound with traverse fibres. The high quality and extremely low-stretch polyester or aramid tension cord is embedded in a rubber compound. It is effectively supported by an upper and substructure. The special characteristics of the raw edge, moulded cogged variable speed belt are:

- high power transmission
- excellent flexibility in running direction
- high traverse stability
- exceptionally smooth running
- wear and slip resistance
- long operational life
- electrically conductive according to ISO 1813

Profiles

Belt widths of up to 100 mm

Belt heights of 5-25 mm

Dimensions

Lengths up to 5000 mm

Standardised dimensions to BS/DIN/ISO and USA standard RMA/MPTA

Application areas

Industrial machinery:	special drives
Variable speed drives:	compact units
Printing machinery:	multi-colour offset drives
Gearboxes:	variable diameter pulley sets
Agricultural machinery:	thresher drum drives
Textile machinery:	winding machinery
Machine tools:	lathes
Automotive technology:	snowmobile drives

optibelt **VARIO POWER** variable speed belts – raw edge, double-cogged

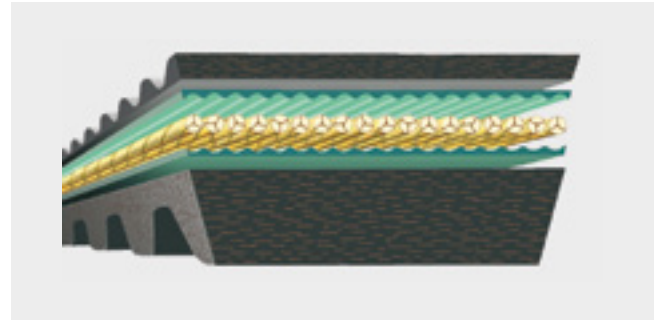

Further increases in demand on the performance of drive elements and the trend towards designing ever smaller, space saving drive units, led to the development of the double-cogged, raw edge optibelt **VARIO POWER** variable speed belt.

Double-cogged OPTIBELT variable speed belts allow for the smallest pulley diameters, even below standard recommendations. The double-cogged design improves heat emission, thereby significantly reducing the belt running temperature. The production methods and the structure of the belt have been derived from the raw edge **VARIO POWER** variable speed belt. Depending upon the application and application range, this belt can also be equipped with layers of special cross-cord material in the base compound. The belt is double-cogged, with the depth and spacing of the cogs matching with the specific belt profile. The polyester or aramid tension cord ensures ideal power transmission, increased service life, and extremely low-stretch characteristics.

The features of the **VARIO POWER** variable speed belt can be summarised as follows:

- extremely high acceptance of axial loads
- high flexibility and flexing rate
- better heat emission
- use with small pulley diameters
- high running smoothness with high belt speeds
- long operational life
- electrically conductive according to ISO 1813

Profiles

Belt widths of 20-85 mm

Belt heights of 10-30 mm

Dimensions

Length ranges from 600-3500 mm

Profiles and dimensions following DIN/ISO and USA standard RMA/MPTA

optibelt **VS** variable speed belts – wrapped

The optibelt **VS** is the first generation of variable speed belts. Its structure complies with the standard constructions of wrapped, classic V-belts or wedge belts.

Profiles and dimensions: on request

PRODUCT DESCRIPTION

optibelt DK DOUBLE-SIDED V-BELTS

Structure

A cross section of the optibelt DK double-sided V-belt reveals a hexagon made up of two congruent trapeziums. The neutral axis containing the tension cord is exactly half way up the belt profile. optibelt DK double-sided V-belts comprise:

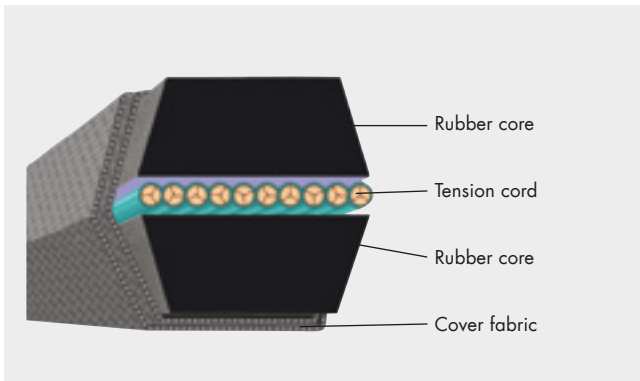

Properties/Application areas

The tension cord positioned at the centre of the belt gives the optibelt DK double-sided V-belts extreme flexibility and low-stretch properties. Thus, the belt is particularly suitable for flexing in different directions in the same plane. optibelt DK double-sided V-belts are used when several pulleys are arranged in one plane and the direction of one or more of the driven pulleys has to be changed without crossing the belts. Due to the position of the tension cord in the neutral axis and the special shape of the double-sided V-belt, the tension cord is not subjected to any force other than tension unlike standard V-belts bent around an outside idler. The optibelt DK double-sided V-belt comes up to typical serpentine arrangements. Special constructions with different top surfaces are possible. Mainly, double-sided V-belts are used in agricultural machinery but also in mechanical engineering.

Standardisation

The cross dimensions of the optibelt DK double-sided V-belts comply with DIN 7722 and ISO 5289.

Table 13

Profile	DIN/ISO designation	HAA	HBB	HCC	HDD	—	—
	Designation	AA	BB	CC	DD	22x22	25x22
Belt width	$b \approx$	13	17	22	32	22	25
Belt height	$h \approx$	10	13	17	25	22	22
Recommended minimum pulley diameter	$d_{a \min}$	80	125	224	355	280	280
Belt weight [kg/m]	\approx	0.150	0.250	0.440	0.935	0.511	0.625
Belt speed [m/s]	$v_{\max} \approx$	30					

This applies to the profiles HAA, HBB, HCC and HDD, in accordance with the USA standard ASAE S 211. ..., thereby ensuring an international interchange. The reference/nominal length of the optibelt DK double-sided V-belt is measured on the effective/outside diameter of the measuring pulley. This length equates to the middle length of the belt.

Conversion factors are as follows:

Profile AA/HAA reference length \approx centre length – 4 mm

Profile BB/HBB reference length \approx centre length – 8 mm

Profile CC/HCC reference length \approx centre length + 3 mm

Profile DD/HDD reference length = centre length.

Experience has shown that in practical use/ordering these conversion factors can be ignored.

Note: Electrically conductive according to ISO 1813.

V-grooved pulleys

No special pulleys are required for optibelt DK double-sided V-belts. Pulleys conforming to ISO 4183, DIN 2211, DIN 2217 and ASAE S 211. ... are suitable.

Profile AA/HAA in grooved pulleys for profile A/13-SPA

Profile BB/HBB in grooved pulleys for profile B/17-SPB

Profile CC/HCC in grooved pulleys for profile C/22-SPC

Profile DD/HDD in grooved pulleys for profile D/32

Special profiles

For special applications, we also supply double-sided V-belts in profiles 22 x 22 and 25 x 22. These are not standardised.

Drive calculation

Drive calculations for optibelt DK double-sided V-belts differ from those given in this manual for two pulley drives. Multi pulley calculations are so complicated that they cannot be presented here.

Reference lengths, rotational speeds, transmission ratios and belt speeds are determined by the reference/outside pulley diameters.

Our Application Engineering Department will be pleased to assist you in the design of drives using optibelt DK double-sided V-belts.

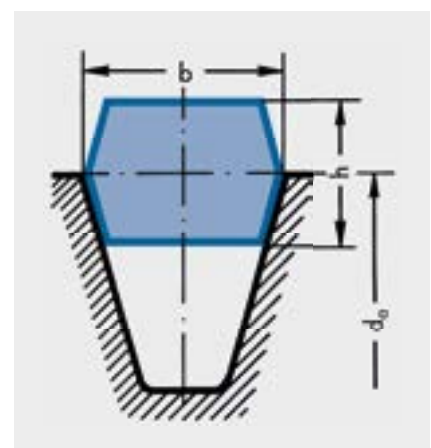

STANDARD PROPERTIES

According to the respective requirements, all OPTIBELT V-belts are manufactured using carefully selected basic materials and continuously updated technical procedures. Regular routine checks during production, elaborate laboratory tests and careful testing of the raw materials used guarantees a consistently high level of quality that can be expected from every OPTIBELT drive element. Reliability and long service life are considered the most important criteria.



Oil resistance

The limited oil resistance prevents the damaging effects of mineral oils and greases, as long as these substances

are not in permanent contact with the timing belt and/or are not present in large quantities. Animal and vegetable fats as well as water-soluble cooling and cutting oils result in a reduction of the service life. For higher concentrations, we recommend the use of our SUPER X-POWER M=S or the special design "05", respectively.



Heat resistance

Standard V-belts allow ambient temperatures of up to +70° C. Temperatures exceeding this range lead to

premature ageing and hardening of V-belts. In such cases, we recommend the use of our special constructions RED POWER 3 or SUPER E-POWER or SUPER X-POWER. For details see page 23.



Dust protection

Dust enormously reduces the service life of V-belts. Wear-resistant fabric covers make OPTIBELT V-belts resistant

to dust. This is demonstrated by their continuous application in cement factories, mills, in the stone processing industries, and in the mining industry.



M=S "Matched Sets"

optibelt SUPER E-POWER M=S, optibelt X-POWER M=S and optibelt SUPER TX M=S are raw edge, mould-

ed cogged V-belts that can be used in sets without measuring. Due to special production processes the narrowest tolerances can be achieved so that V-belts of a given nominal length can be combined without further measurement. The precise edging of the belt results in smooth running. The even power transmission of all belts ensures a high efficiency and saves energy.

Set code numbers are not necessary, there is no set bundling. As a consequence, storage and costs can be reduced.



S=C plus "SetConstant"

This stands for wrapped V-belts that can be used in a set without measuring.

And here are the advantages:

- + saves energy, efficiency of up to 97 %
- + consistent power transmission
- + incorporates the world famous S=C plus tolerances: always at nominal length
- + extremely low-stretch
- + longer service life
- + set code numbers are not required
- + reduces vibrations with resultant smooth running
- + requires only minimal adjustment space
- + reduces self-heating, thus ageing resistant
- + longer maintenance intervals
- + simple storage
- + significant cost reductions

Example of S=C plus length tolerances for a high performance wedge belt with 5000 mm datum length:

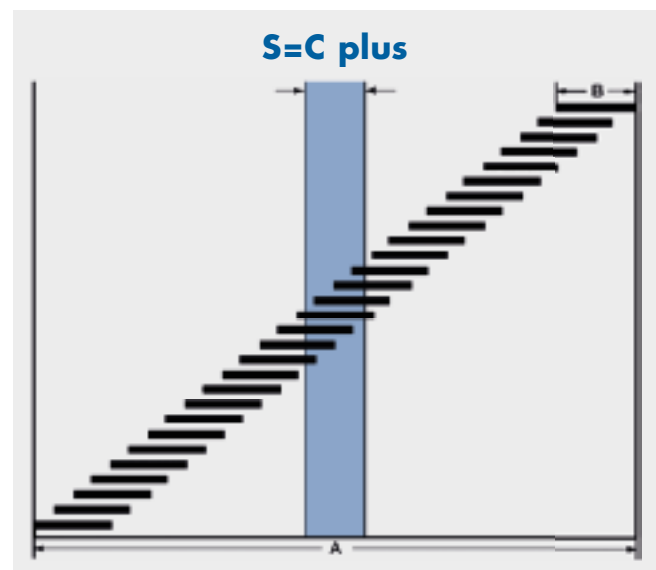

The dimension (A) is the tolerance allowed according to DIN of an individual V-belt with a length of 5000 mm. If you want to install sets for multi-groove drives, the individual elements in a set should not deviate more than 6 mm (B). The tolerance of the optibelt S=C plus V-belt is considerably lower than those allowed according to the standard. S=C plus tolerances are always at nominal length.

SPECIAL CONSTRUCTIONS

Extra heat-resistant V-belts

The service life of standard OPTIBELT V-belts can be massively reduced due to the effects of temperature. In case of ambient temperatures that constantly vary between +70 °C and 90 °C we recommend RED POWER 3, SUPER E-POWER M=S, SUPER X-POWER M=S or SUPER TX M=S belts. Special rubber compounds largely prevent premature ageing and brittleness. In borderline cases, trials are recommended, as individual drive parameters such as belt speed and pulley diameter may influence the operational life.

The diagram below illustrates the great impact of ambient temperature on the operational life of belts. It also presents the optimised operational life of special constructions in high temperature ranges compared to standard constructions. However, you cannot expect the same service life as under normal conditions.

Smooth running selected V-belts

Drives that require a smooth running – that is variations of shaft centre distances – such as lathes and grinders, and are supposed to guarantee a vibration free operation, should be equipped with OPTIBELT V-belts with “selected smooth running”. Fluctuations in the shaft centre distance are electronically measured on testing machines. The measurements comply with the OPTIBELT standards or the conditions agreed upon with our customers.

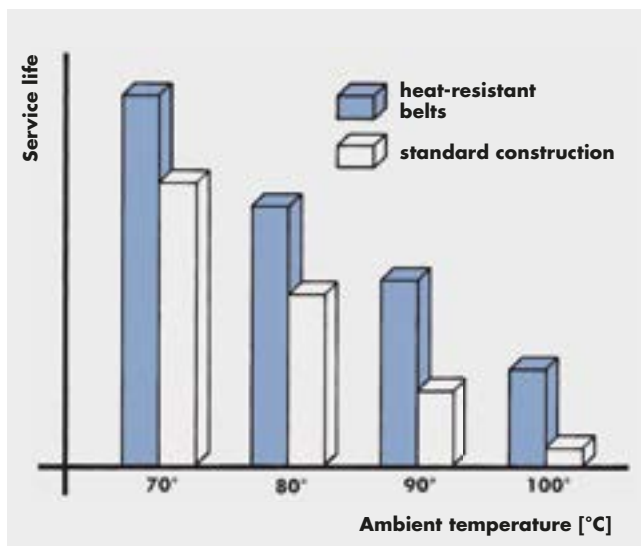

Mining industry

optibelt SK wedge belts and optibelt VB classic V-belts can be used in underground mining as well as in areas above ground that are exposed to explosion and fire risks. For these areas, different national and international testing specifications and standards apply. OPTIBELT “Mining Belts” comply with all requirements of “DIN 22100-7”

Applications with other special constructions

For special applications e.g. in general mechanical engineering, agricultural machinery and horticulture, further special constructions are also available in intermediate sizes for

- special drives with tension, back bend and guide idlers
- clutching drives
- shock loads
- extreme operating conditions

These OPTIBELT V-belts in special constructions have different tension cord types and structures with a variety of rubber compounds, different fabric qualities and a differing number of fabric covers and top surfaces.

All special constructions and intermediate lengths must be ordered in sets or in multiples thereof.

As part of this description not all criteria can be dealt with. For further information please contact our Application Engineering Department.

STANDARD RANGE

optibelt **RED POWER 3** HIGH PERFORMANCE WEDGE BELTS

DIN 7753 PART 1 / ISO 4184

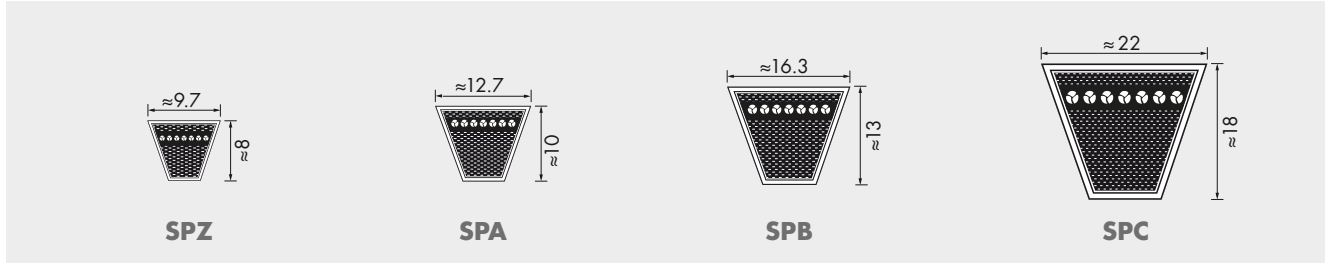

Profile SPZ			Profile SPA				Profile SPB	Profile SPC
Datum length ISO [mm] L _d			Datum length ISO [mm] L _d				Datum length ISO [mm] L _d	Datum length ISO [mm] L _d
1202	1587	2137	1207	1700	2282	3082	1250	2000
1212	1600	2187	1232	1707	2300	3150	1320	2120
1237	1612	2240	1250	1732	2307	3182	1400	2240
1250	1637	2287	1257	1757	2332	3282	1500	2360
1262	1662	2360	1282	1782	2360	3350	1600	2500
1287	1687	2500	1307	1800	2382	3382	1700	2650
1312	1700	2650	1320	1807	2432	3550	1800	2800
1320	1737	2800	1332	1832	2482	3750	1900	3000
1337	1762	3000	1357	1857	2500	4000	2000	3150
1362	1787	3150	1382	1882	2532		2120	3350
1387	1800	3350	1400	1900	2582		2240	3550
1400	1837	3550	1407	1907	2607		2360	3750
1412	1862		1432	1932	2632		2500	4000
1437	1887		1457	1957	2650		2650	4250
1462	1900		1482	1982	2682		2800	4500
1487	1937		1500	2000	2732		3000	4750
1500	1987		1507	2032	2782		3150	5000
1512	2000		1532	2057	2800		3350	5300
1537	2037		1557	2082	2832		3550	5600
1562	2120		1582	2120	2847		3750	6000
			1600	2132	2882		4000	6300
			1607	2182	2932		4250	6700
			1632	2207	2982		4500	7100
			1657	2232	3000		4750	7500
			1682	2240	3032		5000	8000
							5300	8500
							5600	9000
							6000	9500
							6300	10000
							6700	
							7100	
							7500	
							8000	
Maximum production length: 4000 mm Non-standard length ranges on request Weight: ≈ 0.074 kg/m			Maximum production length: 4000 mm Non-standard length ranges on request Weight: ≈ 0.123 kg/m				Maximum production length: 12500 mm Non-standard length ranges on request Weight: ≈ 0.195 kg/m	Maximum production length: 12500 mm Non-standard length ranges on request Weight: ≈ 0.377 kg/m
Datum length L _d ≙ Pitch length L _w /L _p								

Lengths in **bold** type are in S=C plus (SetConstant).

STANDARD RANGE

optibelt **RED POWER 3** HIGH PERFORMANCE WEDGE BELTS

USA STANDARD RMA/MPTA

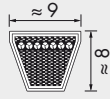

3V/9N

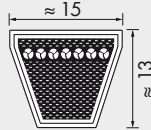

5V/15N

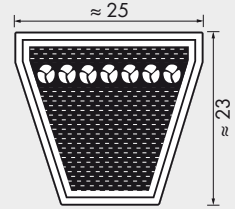

8V/25N

Profile 3V/9N		Profile 5V/15N		Profile 8V/25N	
Belt designation		Belt designation		Belt designation	
Profile, length code	Profile, outside length, L _o (mm)	Profile, length code	Profile, outside length, L _o (mm)	Profile, length code	Profile, outside length, L _o (mm)
3V 475	9N 1206	5V 530	15N 1346	8V 1000	25N 2540
3V 500	9N 1270	5V 560	15N 1422	8V 1120	25N 2845
3V 530	9N 1346	5V 600	15N 1524	8V 1180	25N 2997
3V 560	9N 1422	5V 630	15N 1600	8V 1250	25N 3175
3V 600	9N 1524	5V 670	15N 1702	8V 1320	25N 3353
3V 630	9N 1600	5V 710	15N 1803	8V 1400	25N 3556
3V 670	9N 1702	5V 750	15N 1905	8V 1500	25N 3810
3V 710	9N 1803	5V 800	15N 2032	8V 1600	25N 4064
3V 750	9N 1905	5V 850	15N 2159	8V 1700	25N 4318
3V 800	9N 2032	5V 900	15N 2286	8V 1800	25N 4572
3V 850	9N 2159	5V 950	15N 2413	8V 1900	25N 4826
3V 900	9N 2286	5V 1000	15N 2540	8V 2000	25N 5080
3V 950	9N 2413	5V 1060	15N 2692	8V 2120	25N 5385
3V 1000	9N 2540	5V 1120	15N 2845	8V 2240	25N 5690
3V 1060	9N 2692	5V 1180	15N 2997	8V 2360	25N 5994
3V 1120	9N 2845	5V 1250	15N 3175	8V 2500	25N 6350
3V 1180	9N 2997	5V 1320	15N 3353	8V 2650	25N 6731
3V 1250	9N 3175	5V 1400	15N 3556	8V 2800	25N 7112
3V 1320	9N 3353	5V 1500	15N 3810	8V 3000	25N 7620
3V 1400	9N 3556	5V 1600	15N 4064	8V 3150	25N 8001
		5V 1700	15N 4318	8V 3350	25N 8509
		5V 1800	15N 4572	8V 3550	25N 9017
		5V 1900	15N 4826	8V 3750	25N 9525
		5V 2000	15N 5080	8V 4000	25N 10160
		5V 2120	15N 5385	8V 4250	25N 10795
		5V 2240	15N 5690	8V 4500	25N 11430
		5V 2360	15N 5994	8V 4750	25N 12065
		5V 2500	15N 6350		
		5V 2650	15N 6731		
		5V 2800	15N 7112		
		5V 3000	15N 7620		
		5V 3150	15N 8001		
Maximum production length: 4000 mm L _o Non-standard length ranges on request Weight: ≈ 0.074 kg/m		Maximum production length: 12500 mm L _o Non-standard length ranges on request Weight: ≈ 0.195 kg/m		Maximum production length: 12500 mm L _o Non-standard length ranges on request Weight: ≈ 0.575 kg/m	

Lengths in **bold** type are in S=C plus (SetConstant).

STANDARD RANGE

optibelt **BLUE POWER** HIGH PERFORMANCE WEDGE BELTS

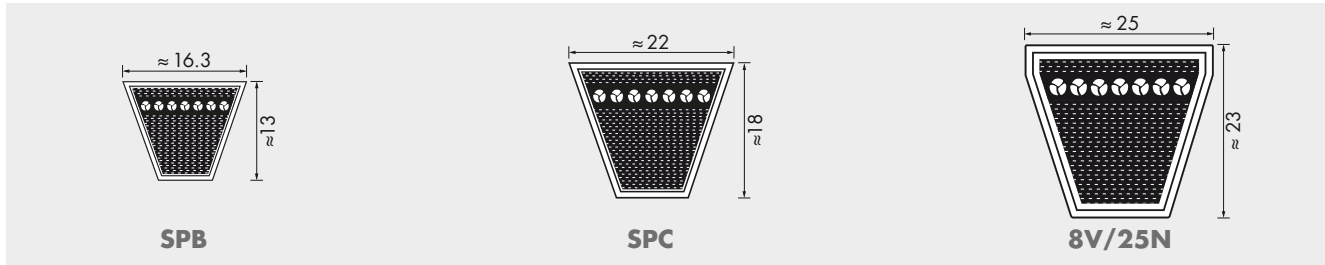

DIN 7753 Part 1 / ISO 4184 / BS 3790

USA Standard RMA / MPTA

Profile SPB		Profile SPC		Profile 8V/25N	
Datum length ISO L_d [mm]		Datum length ISO L_d [mm]		Belt designation	
				Profile, length code	Profile, outside length, L_o [mm]
1500	4750	2000	6300	8V 1600	25N 4064
1600	5000	2120	6700	8V 1700	25N 4318
1700	5300	2240	7100	8V 1800	25N 4572
1800	5600	2360	7500	8V 1900	25N 4826
1900	6000	2500	8000	8V 2000	25N 5080
2000	6300	2650	8500	8V 2120	25N 5385
2120	6700	2800	9000	8V 2240	25N 5690
2240	7100	3000		8V 2360	25N 5994
2360	7500	3150		8V 2500	25N 6350
2500	8000	3350		8V 2650	25N 6731
2650		3550		8V 2800	25N 7112
2800		3750		8V 3000	25N 7620
3000		4000		8V 3150	25N 8001
3150		4250		8V 3350	25N 8509
3350		4500		8V 3550	25N 9017
3550		4750			
3750		5000			
4000		5300			
4250		5600			
4500		6000			
Maximum production length: 18000 mm Minimum order quantity: 1500 mm – 1800 mm = 25 pieces Over 1800 mm = 23 pieces Weight: ≈ 0.206 kg/m		Maximum production length: 18000 mm Minimum order quantity: from 2000 mm = 16 pieces Weight: ≈ 0.389 kg/m		Maximum production length: 18000 mm L_o Minimum order quantity: from 4064 mm L_o = 14 pieces Weight: ≈ 0.603 kg/m	

STANDARD RANGE

optibelt **SK** HIGH PERFORMANCE WEDGE BELTS

DIN 7753 PART 1 / ISO 4184

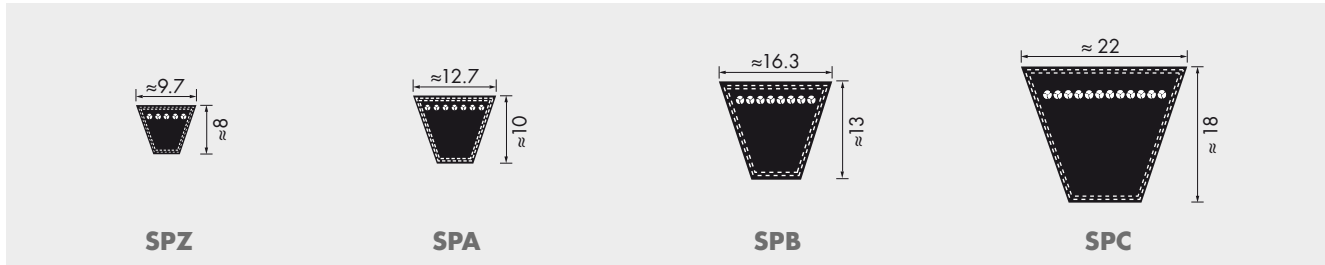

Profile SPZ			Profile SPA				Profile SPB		Profile SPC
Datum length ISO L_d [mm]			Datum length ISO L_d [mm]				Datum length ISO L_d [mm]		Datum length ISO L_d [mm]
487	1047	1662	732	1382	2120	3350	1250	3650	2000
512	1060	1687	757	1400	2132	3382	1320	3750	2120
562	1077	1700	782	1407	2182	3550	1400	3800•	2240
587	1087	1737	800	1432	2207	3750	1450	4000	2360
612	1112	1762	807	1457	2232	4000	1500	4050•	2500
630	1120	1787	832	1482	2240	4250	1600	4250	2650
637	1137	1800	850	1500	2282	4500	1700	4300•	2800
662	1162	1812	857	1507	2300		1750	4500	3000
670	1180	1837	882	1532	2307		1800	4560•	3150
687	1187	1850	900	1557	2332		1850	4750	3350
710	1202	1862	907	1582	2360		1900	4820•	3550
722	1212	1887	932	1600	2382		2000	5000	3750
737	1237	1900	950	1607	2432		2020•	5070•	4000
750	1250	1937	957	1632	2482		2060	5300	4250
762	1262	1987	982	1657	2500		2120	5600	4500
772	1287	2000	1000	1682	2532		2150•	6000	4750
787	1312	2037	1007	1700	2582		2180	6300	5000
800	1320	2120	1032	1707	2607		2240	6700	5300
812	1337	2137	1060	1732	2632		2280•	7100	5600
825	1347	2150•	1082	1757	2650		2360	7500	6000
837	1362	2187	1107	1782	2682		2391	8000	6300
850	1387	2240	1120	1800	2732		2400•		6700
862	1400	2287	1132	1807	2782		2500		7100
875	1412	2360	1157	1832	2800		2650		7500
887	1437	2500	1180	1857	2832		2680•		8000
900	1462	2540•	1207	1882	2847		2800		8500
912	1487	2650	1232	1900	2882		2840•		9000
925	1500	2690•	1250	1907	2932		2850		9500
937	1512	2800	1257	1932	2982		2900		10000
950	1537	2840•	1272	1957	3000		3000		10600
962	1562	3000	1282	1982	3032		3150		11200
987	1587	3150	1307	2000	3082		3250		12500
1000	1600	3350	1320	2032	3150		3350		
1012	1612	3550	1332	2057	3182		3450		
1024	1637		1357	2082	3282		3550		
1037	1650								
Maximum production length: 4500 mm L_d Minimum order quantity: Over 1800 mm = 20 pieces for non-standard length ranges 60 pieces for special constructions Weight: ≈ 0.074 kg/m			Maximum production length: 4500 mm L_d Minimum order quantity: Over 1800 mm = 31 pieces for non-standard length ranges 93 pieces for special constructions Weight: ≈ 0.123 kg/m				Maximum production length: 18000 mm L_d Minimum order quantity: Over 1800 mm = 25 pieces for non-standard length ranges 75 pieces for special constructions Weight: ≈ 0.195 kg/m		Maximum production length: 21000 mm L_d Minimum order quantity: Over 2000 mm = 16 pieces for non-standard length ranges 48 pieces for special constructions Weight: ≈ 0.377 kg/m

Datum length $L_d \triangleq$ Pitch length L_w/L_p

• Non stock items

Lengths in **bold** type are in S=C plus (SetConstant).

STANDARD RANGE

optibelt **SK** HIGH PERFORMANCE WEDGE BELTS

USA STANDARD RMA/MPTA

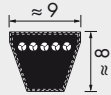

3V/9N

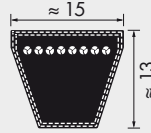

5V/15N

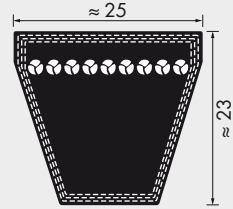

8V/25N

Profile 3V/9N		Profile 5V/15N		Profile 8V/25N	
Belt designation		Belt designation		Belt designation	
Profile, length code	Profile, outside length, L _a (mm)	Profile, length code	Profile, outside length, L _a (mm)	Profile, length code	Profile, outside length, L _a (mm)
3V 250	9N 635	5V 530	15N 1346	8V 1000	25N 2540
3V 265	9N 673	5V 560	15N 1422	8V 1120	25N 2845
3V 280	9N 711	5V 600	15N 1524	8V 1180	25N 2997
3V 300	9N 762	5V 630	15N 1600	8V 1250	25N 3175
3V 315	9N 800	5V 670	15N 1702	8V 1320	25N 3353
3V 335	9N 851	5V 710	15N 1803	8V 1400	25N 3556
3V 355	9N 902	5V 750	15N 1905	8V 1500	25N 3810
3V 375	9N 952	5V 800	15N 2032	8V 1600	25N 4064
3V 400	9N 1016	5V 850	15N 2159	8V 1700	25N 4318
3V 425	9N 1079	5V 900	15N 2286	8V 1800	25N 4572
3V 450	9N 1143	5V 950	15N 2413	8V 1900	25N 4826
3V 475	9N 1206	5V 1000	15N 2540	8V 2000	25N 5080
3V 500	9N 1270	5V 1060	15N 2692	8V 2120	25N 5385
3V 530	9N 1346	5V 1120	15N 2845	8V 2240	25N 5690
3V 560	9N 1422	5V 1180	15N 2997	8V 2360	25N 5994
3V 600	9N 1524	5V 1250	15N 3175	8V 2500	25N 6350
3V 630	9N 1600	5V 1320	15N 3353	8V 2650	25N 6731
3V 670	9N 1702	5V 1400	15N 3556	8V 2800	25N 7112
3V 710	9N 1803	5V 1500	15N 3810	8V 3000	25N 7620
3V 750	9N 1905	5V 1600	15N 4064	8V 3150	25N 8001
3V 800	9N 2032	5V 1700	15N 4318	8V 3350	25N 8509
3V 850	9N 2159	5V 1800	15N 4572	8V 3550	25N 9017
3V 900	9N 2286	5V 1900	15N 4826	8V 3750	25N 9525
3V 950	9N 2413	5V 2000	15N 5080	8V 4000	25N 10160
3V 1000	9N 2540	5V 2120	15N 5385	8V 4250	25N 10795
3V 1060	9N 2692	5V 2240	15N 5690	8V 4500	25N 11430
3V 1120	9N 2845	5V 2360	15N 5994	8V 4750	25N 12065
3V 1180	9N 2997	5V 2500	15N 6350	8V 5000	25N 12700
3V 1250	9N 3175	5V 2650	15N 6731		
3V 1320	9N 3353	5V 2800	15N 7112		
3V 1400	9N 3556	5V 3000	15N 7620		
		5V 3150	15N 8001		
		5V 3350	15N 8509		
		5V 3550	15N 9017		
Maximum production length: 4500 mm L _a Minimum order quantity: Over 1800 mm L _a = 20 pieces for non-standard length ranges 60 pieces for special constructions Weight: ≈ 0.074 kg/m		Maximum production length: 18000 mm L _a Minimum order quantity: Over 1800 mm L _a = 25 pieces for non-standard length ranges 75 pieces for special constructions Weight: ≈ 0.195 kg/m		Maximum standard production length: 21 000 mm L _a Over 18 000 to 21 000 mm on request Minimum order quantity: Over 2540 mm L _a = 11 pieces for non-standard length ranges 33 pieces for special constructions Weight: ≈ 0.575 kg/m	

Lengths in **bold** type are in S=C plus (SetConstant).

STANDARD RANGE

optibelt **VB** CLASSIC V-BELTS

DIN 2215 / ISO 4184



5



Y/6



8

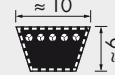

Z/10

Profile 5*		Profile Y/6*		Profile 8		Profile Z/10									
Datum length ISO L _d [mm]	Inside length L _i [mm]	Datum length ISO L _d [mm]	Inside length L _i [mm]	Datum length ISO L _d [mm]	Inside length L _i [mm]	Belt no.	Datum length ISO L _d [mm]	Inside length L _i [mm]	Belt no.	Datum length ISO L _d [mm]	Inside length L _i [mm]	Belt no.	Datum length ISO L _d [mm]	Inside length L _i [mm]	
200	190	295	280	335*	315*	Z 11	312*	290*	Z 38½	997	975	Z 68	1747	1725	
239	229	315	300	375*	355*	Z 12½	337*	315*	Z 39	1022	1000	Z 69	1772	1750	
270	260	350	335	420*	400*	Z 14	397*	375*	Z 40	1038	1016	Z 70	1797	1775	
290	280	415	400	445*	425*	Z 15	422*	400*	Z 40½	1052	1030	Z 71	1822	1800	
310	300	440	425	470*	450*	Z 16	447*	425*	Z 41	1063	1041	Z 73	1872	1850	
325	315	465	450	495*	475*	Z 17	472*	450*	Z 41½	1072	1050	Z 75	1922	1900	
332	322	515	500	510*	490*	Z 18	497*	475*	Z 42	1082	1060	Z 78	1997	1975	
345	335	555	540	550*	530*	Z 19	502*	480*	Z 43	1102	1080	Z 79	2022	2000	
385	375	615	600	580*	560*	Z 19¾	522*	500*	Z 43¼	1122	1100	Z 83½	2142	2120	
435	425	865	850	595*	575*	Z 20	537*	515*	Z 44	1142	1120	Z 88	2262	2240	
485	475			620*	600*	Z 20½	547*	525*	Z 45	1172	1150	Z 93	2382	2360	
510	500			650*	630*	Z 21	552*	530*	Z 46	1187	1165	Z 98	2522	2500	
540	530			690*	670*	Z 21¼	562*	540*	Z 46½	1202	1180				
564	554			720*	700*	Z 22	582*	560*	Z 47	1216	1194				
610	600			730*	710*	Z 23	597	575	Z 48	1237	1215				
				770*	750*	Z 24	622	600	Z 48½	1247	1225				
				795*	775*	Z 25	652	630	Z 49	1272	1250				
				820*	800*	Z 26	672	650	Z 50	1292	1270				
				845	825	Z 27	692	670	Z 51	1317	1295				
				870	850	Z 27½	722	700	Z 52	1342	1320				
				895	875	Z 28	732	710	Z 53	1368	1346				
				920	900	Z 28½	747	725	Z 54	1393	1371				
				970	950	Z 29	752	730	Z 55	1422	1400				
				1020	1000	Z 29½	772	750	Z 56	1444	1422				
				1040	1020	Z 30	787	765	Z 57	1472	1450				
				1070	1050	Z 31	797	775	Z 58	1497	1475				
				1095	1075	Z 31½	822	800	Z 59	1522	1500				
				1140	1120	Z 32	842	820	Z 60	1546	1524				
				1220	1200	Z 33	847	825	Z 61	1572	1550				
				1270	1250	Z 33½	872	850	Z 62	1597	1575				
						Z 34	887	865	Z 63	1622	1600				
						Z 35	897	875	Z 64	1648	1626				
						Z 36	922	900	Z 65	1673	1651				
						Z 37	947	925	Z 66	1697	1675				
						Z 38	972	950	Z 67	1722	1700				
Further sizes on request Weight: ≈ 0.018 kg/m	Further sizes on request Weight: ≈ 0.026 kg/m	Weight: ≈ 0.042 kg/m	Maximum production length: 4500 mm Minimum order quantity: Over 1800 mm = 20 pieces for non-standard length ranges 60 pieces for special constructions Weight: ≈ 0.064 kg/m												

Datum length L_d ≙ Pitch length L_w/L_p * Raw edge, moulded cogged V-belts Further sizes on request

Lengths in **bold** type are in S=C plus (SetConstant).

STANDARD RANGE

optibelt **VB** CLASSIC V-BELTS

DIN 2215 / ISO 4184

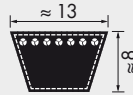

A/13

Profile A/13											
Belt no.	Datum length ISO L_d [mm]	Inside length L_i [mm]	Belt no.	Datum length ISO L_d [mm]	Inside length L_i [mm]	Belt no.	Datum length ISO L_d [mm]	Inside length L_i [mm]	Belt no.	Datum length ISO L_d [mm]	Inside length L_i [mm]
A 16	437	407	A 41	1071	1041	A 69	1780	1750	A 105	2697	2667
A 18	487	457	A 41½	1080	1050	A 70	1805	1775	A 107	2755	2725
A 19	510	480	A 42	1090	1060	A 71	1830	1800	A 108	2773	2743
A 20	538	508	A 42½	1105	1075	A 72	1855	1825	A 110	2830	2800
A 21	565	535	A 43	1130	1100	A 73	1884	1854	A 112	2875	2845
A 22	590	560	A 43½	1135	1105	A 74	1910	1880	A 114	2926	2896
A 23	605	575	A 44	1150	1120	A 75	1930	1900	A 116	2976	2946
A 23½	630	600	A 45	1173	1143	A 76	1960	1930	A 118	3030	3000
A 24	640	610	A 45½	1180	1150	A 77	1986	1956	A 120	3078	3048
A 25	660	630	A 46	1198	1168	A 78	2010	1980	A 124	3180	3150
A 26	680	650	A 46½	1210	1180	A 79	2030	2000	A 128	3280	3250
A 26½	700	670	A 47	1230	1200	A 80	2062	2032	A 132	3380	3350
A 27	716	686	A 47½	1245	1215	A 81	2090	2060	A 136	3484	3454
A 27½	730	700	A 48	1250	1220	A 82	2113	2083	A 140	3580	3550
A 28	740	710	A 48½	1255	1225	A 83	2130	2100	A 144	3688	3658
A 29	760	730	A 49	1280	1250	A 83½	2150	2120	A 148	3780	3750
A 29½	780	750	A 50	1300	1270	A 84	2164	2134	A 158	4030	4000
A 30	797	767	A 51	1330	1300	A 84½	2180	2150	A 167	4280	4250
A 31	805	775	A 52	1350	1320	A 85	2190	2160	A 187	4780	4750
A 31½	830	800	A 53	1380	1350	A 86½	2230	2200	A 197	5030	5000
A 32	843	813	A 54	1405	1375	A 87	2240	2210			
A 32½	855	825	A 55	1430	1400	A 88	2270	2240			
A 33	871	841	A 56	1452	1422	A 89	2291	2261			
A 34	880	850	A 57	1480	1450	A 90	2316	2286			
A 34½	905	875	A 58	1505	1475	A 91	2341	2311			
A 35	919	889	A 59	1530	1500	A 92	2367	2337			
A 35½	930	900	A 60	1555	1525	A 93	2390	2360			
A 36	944	914	A 61	1580	1550	A 94	2418	2388			
A 37	955	925	A 62	1605	1575	A 95	2443	2413			
A 37½	980	950	A 63	1630	1600	A 96	2468	2438			
A 38	995	965	A 64	1655	1625	A 97	2494	2464			
A 38½	1005	975	A 65	1680	1650	A 98	2530	2500			
A 39	1030	1000	A 66	1706	1676	A 100	2570	2540			
A 40	1046	1016	A 67	1730	1700	A 102	2621	2591			
A 40½	1060	1030	A 68	1755	1725	A 104	2680	2650			

Maximum production length: 10000 mm L_i
 Minimum order quantity:
 Over 1800 mm =
 31 pieces for non-standard length ranges
 93 pieces for special constructions
 Weight: ≈ 0.109 kg/m

Datum length $L_d \triangleq$ Pitch length L_w/L_p Further sizes on request

Lengths in **bold** type are in S=C plus (SetConstant).

STANDARD RANGE

optibelt **VB** CLASSIC V-BELTS

DIN 2215 / ISO 4184

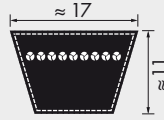

B/17

Profile B/17

Belt no.	Datum length ISO L_d [mm]	Inside length L_i [mm]	Belt no.	Datum length ISO L_d [mm]	Inside length L_i [mm]	Belt no.	Datum length ISO L_d [mm]	Inside length L_i [mm]	Belt no.	Datum length ISO L_d [mm]	Inside length L_i [mm]
B 23	610	570	B 51	1340	1300	B 87	2250	2210	B 140	3590	3550
B 24	655	615	B 52	1360	1320	B 88	2280	2240	B 142	3640	3600
B 25	670	630	B 52½	1375	1335	B 89	2301	2261	B 144	3698	3658
B 26	690	650	B 53	1390	1350	B 90	2326	2286	B 146	3740	3700
B 26½	710	670	B 53½	1400	1360	B 91	2340	2300	B 148	3790	3750
B 27	726	686	B 54	1412	1372	B 92	2377	2337	B 150	3850	3810
B 28	750	710	B 55	1440	1400	B 93	2400	2360	B 151	3890	3850
B 29	765	725	B 56	1462	1422	B 94	2428	2388	B 152	3901	3861
B 30	790	750	B 57	1490	1450	B 94½	2440	2400	B 154	3952	3912
B 31	815	775	B 58	1513	1473	B 95	2453	2413	B 155	3990	3950
B 32	840	800	B 59	1540	1500	B 96	2478	2438	B 156	4002	3962
B 32½	865	825	B 60	1565	1525	B 96½	2490	2450	B 158	4040	4000
B 33	876	836	B 61	1590	1550	B 97	2505	2465	B 160	4104	4064
B 34	890	850	B 62	1615	1575	B 98	2540	2500	B 162	4155	4115
B 34½	915	875	B 63	1640	1600	B 99	2555	2515	B 165	4240	4200
B 35	929	889	B 64	1665	1625	B 100	2580	2540	B 167	4290	4250
B 36	940	900	B 65	1690	1650	B 101	2605	2565	B 173	4434	4394
B 37	965	925	B 66	1716	1676	B 102	2640	2600	B 175	4490	4450
B 37½	990	950	B 67	1740	1700	B 103	2656	2616	B 177	4540	4500
B 38	1005	965	B 68	1765	1725	B 104	2690	2650	B 180	4612	4572
B 38½	1015	975	B 69	1790	1750	B 105	2707	2667	B 187	4790	4750
B 39	1040	1000	B 69½	1801	1761	B 106	2740	2700	B 195	4993	4953
B 40	1056	1016	B 70	1815	1775	B 107	2758	2718	B 197	5040	5000
B 40½	1070	1030	B 71	1840	1800	B 108	2790	2750	B 208	5340	5300
B 41	1080	1040	B 72	1869	1829	B 110	2840	2800	B 210	5374	5334
B 41½	1090	1050	B 73	1890	1850	B 112	2885	2845	B 220	5640	5600
B 42	1100	1060	B 74	1920	1880	B 114	2940	2900	B 236	6040	6000
B 42½	1115	1075	B 75	1940	1900	B 115	2961	2921	B 240	6136	6096
B 43	1130	1090	B 76	1970	1930	B 116	2990	2950	B 248	6340	6300
B 43¼	1140	1100	B 77	1990	1950	B 118	3040	3000	B 264	6740	6700
B 44	1160	1120	B 78	2021	1981	B 120	3088	3048	B 276	7040	7000
B 45	1190	1150	B 79	2040	2000	B 122	3139	3099	B 280	7140	7100
B 45½	1203	1163	B 80	2072	2032	B 124	3190	3150			
B 46	1215	1175	B 81	2100	2060	B 126	3240	3200			
B 46½	1220	1180	B 82	2123	2083	B 128	3290	3250			
B 47	1240	1200	B 83	2140	2100	B 130	3342	3302			
B 48	1255	1215	B 83½	2160	2120	B 132	3390	3350			
B 48½	1265	1225	B 84	2174	2134	B 134	3444	3404			
B 49	1290	1250	B 85	2200	2160	B 136	3490	3450			
B 50	1315	1275	B 86	2240	2200	B 138	3545	3505			

Maximum production length: 21 000 mm L_i
 Minimum order quantity:
 Over 1800 mm =
 21 pieces for non-standard length ranges
 63 pieces for special constructions
 Weight: ≈ 0.196 kg/m

Datum length $L_d \triangleq$ Pitch length L_w/L_p Further sizes on request

Lengths in **bold** type are in S=C plus (SetConstant).

STANDARD RANGE

optibelt **VB** CLASSIC V-BELTS

DIN 2215 / ISO 4184

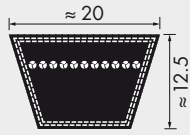

20

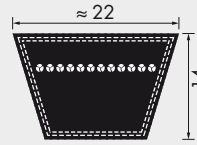

C/22

Profile 20		Profile C/22								
Datum length ISO L _d [mm]	Inside length L _i [mm]	Belt no.	Datum length ISO L _d [mm]	Inside length L _i [mm]	Belt no.	Datum length ISO L _d [mm]	Inside length L _i [mm]	Belt no.	Datum length ISO L _d [mm]	Inside length L _i [mm]
950	900	C 43	1148	1090	C 84	2192	2134	C 134	3462	3404
1050	1000	C 47	1258	1200	C 85	2217	2159	C 136	3508	3450
1170	1120	C 48	1273	1215	C 86	2242	2184	C 138	3563	3505
1230	1180	C 49	1308	1250	C 87	2268	2210	C 140	3608	3550
1300	1250	C 51	1353	1295	C 88	2298	2240	C 142	3665	3607
1370	1320	C 52	1378	1320	C 89	2319	2261	C 144	3716	3658
1450	1400	C 53	1408	1350	C 90	2344	2286	C 146	3758	3700
1550	1500	C 54	1433	1375	C 92	2395	2337	C 148	3808	3750
1650	1600	C 55	1458	1400	C 93	2418	2360	C 150	3868	3810
1750	1700	C 56	1483	1425	C 94	2446	2388	C 158	4058	4000
1850	1800	C 57	1508	1450	C 95	2471	2413	C 162	4158	4100
1950	1900	C 58	1533	1475	C 96	2496	2438	C 166	4274	4216
2050	2000	C 59	1558	1500	C 96 ^{1/2}	2508	2450	C 167	4308	4250
2170	2120	C 60	1582	1524	C 97	2522	2464	C 168	4325	4267
2290	2240	C 61	1608	1550	C 98	2558	2500	C 170	4376	4318
2410	2360	C 62	1632	1574	C 99	2583	2525	C 173	4452	4394
2550	2500	C 63	1658	1600	C 100	2598	2540	C 175	4503	4445
2700	2650	C 65	1708	1650	C 101	2618	2560	C 177	4558	4500
2850	2800	C 66	1734	1676	C 102	2649	2591	C 180	4630	4572
3050	3000	C 67	1758	1700	C 104	2700	2642	C 187	4808	4750
3200	3150	C 68	1785	1727	C 105	2725	2667	C 190	4884	4826
3400	3350	C 69	1808	1750	C 106	2750	2692	C 195	5011	4953
3600	3550	C 70	1836	1778	C 108	2808	2750	C 197	5058	5000
3800	3750	C 71	1858	1800	C 110	2858	2800	C 208	5358	5300
4050	4000	C 72	1887	1829	C 112	2903	2845	C 210	5392	5334
4550	4500	C 73	1912	1854	C 114	2954	2896	C 220	5658	5600
5050	5000	C 74	1938	1880	C 115	2979	2921	C 225	5773	5715
6050	6000	C 75	1958	1900	C 116	3008	2950	C 236	6058	6000
		C 76	1988	1930	C 117	3023	2965	C 240	6154	6096
		C 77	2014	1956	C 118	3058	3000	C 248	6358	6300
		C 78	2039	1981	C 120	3106	3048	C 264	6758	6700
		C 79	2058	2000	C 122	3157	3099	C 270	6916	6858
		C 80	2090	2032	C 124	3208	3150	C 280	7158	7100
		C 81	2118	2060	C 126	3258	3200	C 295	7558	7500
		C 82	2141	2083	C 128	3308	3250	C 300	7678	7620
		C 83	2166	2108	C 130	3360	3302	C 315	8058	8000
		C 83 ^{1/2}	2178	2120	C 132	3408	3350			

Maximum production length:
10000 mm L_i
Minimum order quantity:
Over 1800 mm =
18 pieces for non-standard
length ranges
54 pieces for special
constructions
Weight: ≈ 0.266 kg/m

Maximum standard production length: 21 000 mm L_i
Over 18 000 to 21 000 mm on request
Minimum order quantity:
Over 1800 mm =
16 pieces for non-standard length ranges
48 pieces for special constructions
Weight: ≈ 0.324 kg/m

Datum length L_d ≙ Pitch length L_w/L_p Further sizes on request

Lengths in **bold** type are in S=C plus (SetConstant).

STANDARD RANGE

optibelt **VB** CLASSIC V-BELTS

DIN 2215 / ISO 4184

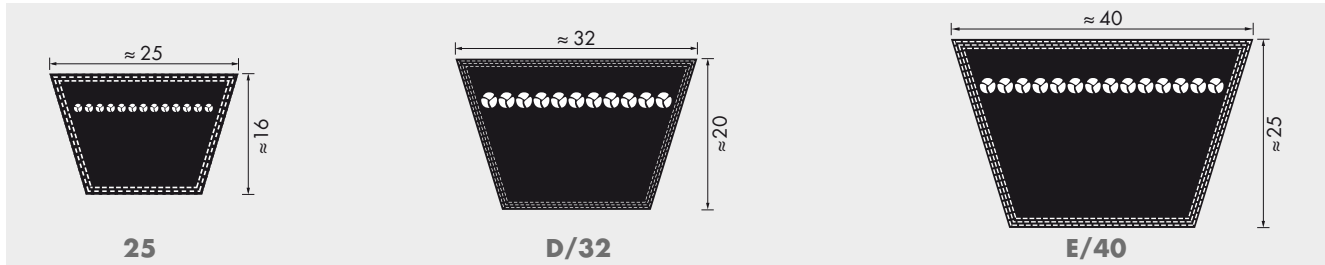

Profile 25		Profile D/32			Profile E/40		
Datum length ISO L_d [mm]	Inside length L_i [mm]	Belt no.	Datum length ISO L_d [mm]	Inside length L_i [mm]	Belt no.	Datum length ISO L_d [mm]	Inside length L_i [mm]
1460	1400	D 79	2075	2000	E 118	3080	3000
1560	1500	D 98	2575	2500	E 158	4080	4000
1660	1600	D 104	2725	2650	E 197	5080	5000
1760	1700	D 110	2875	2800	E 220	5680	5600
1860	1800	D 118	3075	3000	E 236	6080	6000
1960	1900	D 120	3123	3048	E 248	6380	6300
2060	2000	D 124	3225	3150	E 280	7180	7100
2180	2120	D 128	3326	3251	E 295	7580	7500
2300	2240	D 132	3425	3350	E 315	8080	8000
2420	2360	D 135	3500	3425	E 354	9080	9000
2560	2500	D 136	3529	3454	E 394	10080	10000
2710	2650	D 140	3625	3550	E 441	11280	11200
2760	2700	D 144	3733	3658	E 492	12580	12500
2860	2800	D 148	3825	3750			
3060	3000	D 154	4000	3925			
3210	3150	D 158	4075	4000			
3410	3350	D 162	4190	4115			
3610	3550	D 167	4325	4250			
3810	3750	D 173	4469	4394			
4060	4000	D 177	4575	4500			
4310	4250	D 180	4647	4572			
4560	4500	D 187	4825	4750			
4810	4750	D 195	5028	4953			
5060	5000	D 197	5075	5000			
5360	5300	D 208	5375	5300			
5660	5600	D 210	5409	5334			
6060	6000	D 220	5675	5600			
6360	6300	D 225	5790	5715			
6760	6700	D 236	6075	6000			
7160	7100	D 240	6171	6096			
7560	7500	D 248	6375	6300			
8060	8000	D 264	6775	6700			
8560	8500	D 270	6933	6858			
9060	9000	D 280	7175	7100			
		D 295	7575	7500			
		D 300	7695	7620			
		D 315	8075	8000			
		D 330	8457	8382			
		D 335	8575	8500			
		D 354	9075	9000			
		D 374	9575	9500			
		D 394	10075	10000			
		D 441	11275	11200			
Maximum standard production length: 21 000 mm L_i Over 18 000 to 21 000 mm on request Minimum order quantity: Over 1800 mm = 14 pieces for non-standard length ranges 42 pieces for certain special constructions Weight: \approx 0.420 kg/m		Maximum standard production length: 21 000 mm L_i Over 18 000 to 21 000 mm on request Minimum order quantity: Over 2000 mm = 11 pieces for non-standard length ranges 33 pieces for certain special constructions Weight: \approx 0.668 kg/m			Maximum production length: 21 000 mm L_i Minimum order quantity: Over 3000 mm = 7 pieces for non-standard length ranges 21 pieces for certain special constructions Weight: \approx 0.958 kg/m		
Datum length $L_d \triangleq$ Pitch length L_w/L_p Further sizes on request							

Lengths in **bold** type are in S=C plus (SetConstant).

STANDARD RANGE

optibelt **RED POWER 3** KRAFTBANDS

WITH HIGH PERFORMANCE WEDGE BELTS DIN/ISO

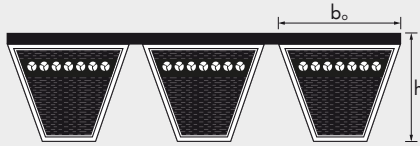

Profile	SPB	SPC
$b_o \approx$ [mm]	16.5	22.0
$h \approx$ [mm]	15.6	22.6

Profile SPB	Profile SPC
Datum length ISO L_d [mm]	Datum length ISO L_d [mm]
2000	3000
2120	3150
2240	3350
2360	3550
2500	3750
2650	4000
2800	4250
3000	4500
3150	4750
3350	5000
3550	5300
3750	5600
4000	6000
4250	6300
4500	6700
4750	7100
5000	7500
5300	8000
5600	8500
6000	9000
6300	9500
6700	10000
7100	
7500	
8000	
Maximum production length: 10000 mm L_d	Maximum production length: 10000 mm L_d
Non-standard length ranges on request	Non-standard length ranges on request
Weight: per rib \approx 0.261 kg/m	Weight: per rib \approx 0.555 kg/m

Datum length $L_d \triangleq$ Pitch length L_w/L_p Further sizes on request

STANDARD RANGE

optibelt **RED POWER 3** KRAFTBANDS

WITH HIGH PERFORMANCE WEDGE BELTS RMA/MPTA

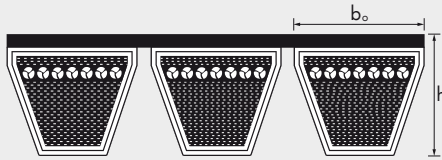

Profile	3V/9J	5V/15J	8V/25J
$b_o \approx$ [mm]	9.0	15.0	25.0
$h \approx$ [mm]	9.9	15.1	25.5

Profile 3V/9J		Profile 5V/15J		Profile 8V/25J	
Belt designation		Belt designation		Belt designation	
Profile, length code	Profile, outside length, L_o [mm]	Profile, length code	Profile, outside length, L_o [mm]	Profile, length code	Profile, outside length, L_o [mm]
3V 500	9J 1270	5V 560	15J 1422	8V 1000	25J 2540
3V 530	9J 1346	5V 600	15J 1524	8V 1060	25J 2692
3V 560	9J 1422	5V 630	15J 1600	8V 1120	25J 2845
3V 600	9J 1524	5V 670	15J 1702	8V 1180	25J 2997
3V 630	9J 1600	5V 710	15J 1803	8V 1250	25J 3175
3V 670	9J 1702	5V 750	15J 1905	8V 1320	25J 3353
3V 710	9J 1803	5V 800	15J 2032	8V 1400	25J 3556
3V 750	9J 1905	5V 850	15J 2159	8V 1500	25J 3810
3V 800	9J 2032	5V 900	15J 2286	8V 1600	25J 4064
3V 850	9J 2159	5V 950	15J 2413	8V 1700	25J 4318
3V 900	9J 2286	5V 1000	15J 2540	8V 1800	25J 4572
3V 950	9J 2413	5V 1060	15J 2692	8V 1900	25J 4826
3V 1000	9J 2540	5V 1120	15J 2845	8V 2000	25J 5080
3V 1060	9J 2692	5V 1180	15J 2997	8V 2120	25J 5385
3V 1120	9J 2845	5V 1250	15J 3175	8V 2240	25J 5690
3V 1180	9J 2997	5V 1320	15J 3353	8V 2360	25J 5994
3V 1250	9J 3175	5V 1400	15J 3556	8V 2500	25J 6350
3V 1320	9J 3353	5V 1500	15J 3810	8V 2650	25J 6731
3V 1400	9J 3556	5V 1600	15J 4064	8V 2800	25J 7112
		5V 1700	15J 4318	8V 3000	25J 7620
		5V 1800	15J 4572	8V 3150	25J 8001
		5V 1900	15J 4826	8V 3350	25J 8509
		5V 2000	15J 5080	8V 3550	25J 9017
		5V 2120	15J 5385	8V 3750	25J 9525
		5V 2240	15J 5690	8V 4000	25J 10160
		5V 2360	15J 5994	8V 4250	25J 10795
		5V 2500	15J 6350	8V 4500	25J 11430
		5V 2650	15J 6731	8V 4750	25J 12065
		5V 2800	15J 7112		
		5V 3000	15J 7620		
		5V 3150	15J 8001		
Maximum production length: 4000 mm L_o Non-standard length ranges on request Weight: per rib \approx 0.122 kg/m		Maximum production length: 10000 mm L_o Non-standard length ranges on request Weight: per rib \approx 0.252 kg/m		Maximum production length: 18000 mm L_o Non-standard length ranges on request Weight: per rib \approx 0.693 kg/m	

Further sizes on request

STANDARD RANGE

optibelt **BLUE POWER** KRAFTBANDS

WITH HIGH PERFORMANCE WEDGE BELTS

DIN 7753 PART 1 / ISO 4184

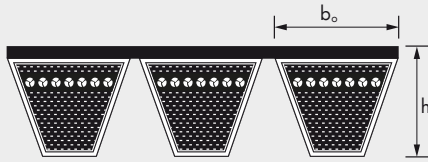

Profile	SPB	SPC
$b_o \approx$ [mm]	16.5	22.0
$h \approx$ [mm]	15.6	22.6

Profile SPB	Profile SPC
Datum length ISO L_d [mm]	Datum length ISO L_d [mm]
2000	3000
2120	3150
2240	3350
2360	3550
2500	3750
2650	4000
2800	4250
3000	4500
3150	4750
3350	5000
3550	5300
3750	5600
4000	6000
4250	6300
4500	6700
4750	7100
5000	7500
5300	8000
5600	8500
6000	9000
6300	9500
6700	10000
7100	
7500	
8000	
<p>Maximum production length: 10000 mm L_d Non-standard length ranges from 2000 mm L_d Minimum order quantity: from 2000 mm L_d 4 pieces with 5 ribs or 5 pieces with 4 ribs or 7 pieces with 3 ribs or 11 pieces with 2 ribs or a multiple thereof Weight: per rib \approx 0.283 kg/m</p>	<p>Maximum production length: 10000 mm L_d Non-standard length ranges from 3000 mm L_d Minimum order quantity: 3 pieces with 5 ribs or 4 pieces with 4 ribs or 5 pieces with 3 ribs or 8 pieces with 2 ribs or a multiple thereof Weight: per rib \approx 0.567 kg/m</p>

Datum length $L_d \triangleq$ Pitch length L_w/L_p Further sizes on request

STANDARD RANGE

optibelt **BLUE POWER** KRAFTBANDS

WITH HIGH PERFORMANCE WEDGE BELTS

USA STANDARD RMA/MPTA

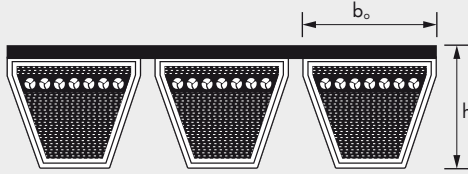

Profile	5V/15J	8V/25J
$b_o \approx$ [mm]	15.0	25.0
$h \approx$ [mm]	15.1	25.5

Profile 5V/15J		Profile 8V/25J	
Belt designation		Belt designation	
Profile, length code	Profile, outside length, L_d [mm]	Profile, length code	Profile, outside length, L_d [mm]
5V 800	15J 2032	8V 1000	25J 2540
5V 850	15J 2159	8V 1060	25J 2692
5V 900	15J 2286	8V 1120	25J 2845
5V 950	15J 2413	8V 1180	25J 2997
5V 1000	15J 2540	8V 1250	25J 3175
5V 1060	15J 2692	8V 1320	25J 3353
5V 1120	15J 2845	8V 1400	25J 3556
5V 1180	15J 2997	8V 1500	25J 3810
5V 1250	15J 3175	8V 1600	25J 4064
5V 1320	15J 3353	8V 1700	25J 4318
5V 1400	15J 3556	8V 1800	25J 4572
5V 1500	15J 3810	8V 1900	25J 4826
5V 1600	15J 4064	8V 2000	25J 5080
5V 1700	15J 4318	8V 2120	25J 5385
5V 1800	15J 4572	8V 2240	25J 5690
5V 1900	15J 4826	8V 2360	25J 5994
5V 2000	15J 5080	8V 2500	25J 6350
5V 2120	15J 5385	8V 2650	25J 6731
5V 2240	15J 5690	8V 2800	25J 7112
5V 2360	15J 5994	8V 3000	25J 7620
5V 2500	15J 6350	8V 3150	25J 8001
5V 2650	15J 6731	8V 3350	25J 8509
5V 2800	15J 7112	8V 3550	25J 9017
5V 3000	15J 7620	8V 3750	25J 9525
5V 3150	15J 8001	8V 4000	25J 10160
		8V 4250	25J 10795
		8V 4500	25J 11430
		8V 4750	25J 12065

<p>Maximum production length: 18 000 mm L_d Non-standard length ranges from 2032 mm L_d Minimum order quantity: 6 pieces with 5 ribs or 7 pieces with 4 ribs or 10 pieces with 3 ribs or 15 pieces with 2 ribs or a multiple thereof</p> <p>Weight: per rib \approx 0.253 kg/m</p>	<p>Maximum production length: 18 000 mm L_d Non-standard length ranges from 2540 mm L_d Minimum order quantity: 3 pieces with 5 ribs or 3 pieces with 4 ribs or 5 pieces with 3 ribs or 7 pieces with 2 ribs or a multiple thereof</p> <p>Weight: per rib \approx 0.738 kg/m</p>
--	--

Further sizes on request

STANDARD RANGE

optibelt **KB** KRAFTBANDS WITH WEDGE BELTS

DIN/ISO

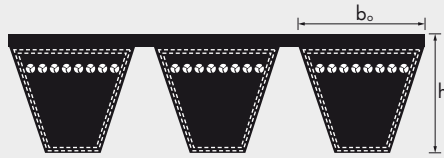

Profile	SPZ	SPA	SPB	SPC
$b_o \approx$ [mm]	9.7	12.7	16.5	22.0
$h \approx$ [mm]	10.5	12.5	15.6	22.6

Profile SPZ	Profile SPA	Profile SPB	Profile SPC
Datum length ISO L_d [mm]	Datum length ISO L_d [mm]	Datum length ISO L_d [mm]	Datum length ISO L_d [mm]
1250	1250	2000	3000
1400	1400	2120	3150
1500	1500	2240	3350
1600	1600	2360	3550
1700	1700	2500	3750
1800	1800	2650	4000
1900	1900	2800	4250
2000	2000	3000	4500
2120	2120	3150	4750
2240	2240	3350	5000
2360	2360	3550	5300
2500	2500	3750	5600
2650	2650	4000	6000
2800	2800	4250	6300
3000	3000	4500	6700
3150	3150	4750	7100
3350	3350	5000	7500
3550	3550	5300	8000
	3750	5600	8500
	4000	6000	9000
	4250	6300	9500
	4500	6700	10000
		7100	10600
		7500	11200
		8000	11800
			12500
Maximum production length: 4500 mm L_d Non-standard length ranges from 1800 mm L_d Minimum order quantity for special length ranges: 8 pieces with 5 ribs or 10 pieces with 4 ribs or 14 pieces with 3 ribs or 21 pieces with 2 ribs or a multiple thereof Weight: per rib \approx 0.120 kg/m Minimum order quantity for design with aramid tension cord on request	Maximum production length: 4500 mm L_d Non-standard length ranges from 1800 mm L_d Minimum order quantity for all length ranges: 6 pieces with 5 ribs or 8 pieces with 4 ribs or 11 pieces with 3 ribs or 16 pieces with 2 ribs or a multiple thereof Weight: per rib \approx 0.166 kg/m Minimum order quantity for design with aramid tension cord on request	Maximum production length: 10000 mm L_d Non-standard length ranges from 2000 mm L_d Minimum order quantity for special length ranges: 4 pieces with 5 ribs or 5 pieces with 4 ribs or 7 pieces with 3 ribs or 11 pieces with 2 ribs or a multiple thereof Weight: per rib \approx 0.261 kg/m Minimum order quantity for design with aramid tension cord on request	Maximum production length: 12500 mm L_d Non-standard length ranges from 3000 mm L_d Minimum order quantity for all length ranges: 3 pieces with 5 ribs or 4 pieces with 4 ribs or 5 pieces with 3 ribs or 8 pieces with 2 ribs or a multiple thereof Weight: per rib \approx 0.555 kg/m Minimum order quantity for design with aramid tension cord on request

Datum length $L_d \triangleq$ Pitch length L_w/L_p Further sizes on request

STANDARD RANGE

optibelt **KB** KRAFTBANDS WITH WEDGE BELTS

RMA/MPTA

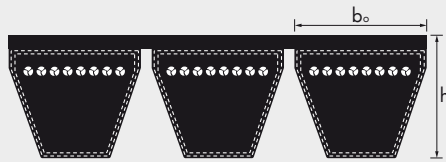

Profile	3V/9J	5V/15J	8V/25J
$b_o \approx$ [mm]	9.0	15.0	25.0
$h \approx$ [mm]	9.9	15.1	25.5

Profile 3V/9J		Profile 5V/15J		Profile 8V/25J	
Belt designation		Belt designation		Belt designation	
Profile, length code	Profile, outside length, L_o [mm]	Profile, length code	Profile, outside length, L_o [mm]	Profile, length code	Profile, outside length, L_o [mm]
3V 500	9J 1270	5V 560	15J 1422	8V 1000	25J 2540
3V 530	9J 1346	5V 600	15J 1524	8V 1060	25J 2692
3V 560	9J 1422	5V 630	15J 1600	8V 1120	25J 2845
3V 600	9J 1524	5V 670	15J 1702	8V 1180	25J 2997
3V 630	9J 1600	5V 710	15J 1803	8V 1250	25J 3175
3V 670	9J 1702	5V 750	15J 1905	8V 1320	25J 3353
3V 710	9J 1803	5V 800	15J 2032	8V 1400	25J 3556
3V 750	9J 1905	5V 850	15J 2159	8V 1500	25J 3810
3V 800	9J 2032	5V 900	15J 2286	8V 1600	25J 4064
3V 850	9J 2159	5V 950	15J 2413	8V 1700	25J 4318
3V 900	9J 2286	5V 1000	15J 2540	8V 1800	25J 4572
3V 950	9J 2413	5V 1060	15J 2692	8V 1900	25J 4826
3V 1000	9J 2540	5V 1120	15J 2845	8V 2000	25J 5080
3V 1060	9J 2692	5V 1180	15J 2997	8V 2120	25J 5385
3V 1120	9J 2845	5V 1250	15J 3175	8V 2240	25J 5690
3V 1180	9J 2997	5V 1320	15J 3353	8V 2360	25J 5994
3V 1250	9J 3175	5V 1400	15J 3556	8V 2500	25J 6350
3V 1320	9J 3353	5V 1500	15J 3810	8V 2650	25J 6731
3V 1400	9J 3556	5V 1600	15J 4064	8V 2800	25J 7112
		5V 1700	15J 4318	8V 3000	25J 7620
		5V 1800	15J 4572	8V 3150	25J 8001
		5V 1900	15J 4826	8V 3350	25J 8509
		5V 2000	15J 5080	8V 3550	25J 9017
		5V 2120	15J 5385	8V 3750	25J 9525
		5V 2240	15J 5690	8V 4000	25J 10160
		5V 2360	15J 5994	8V 4250	25J 10795
		5V 2500	15J 6350	8V 4500	25J 11430
		5V 2650	15J 6731	8V 4750	25J 12065
		5V 2800	15J 7112		
		5V 3000	15J 7620		
		5V 3150	15J 8001		
		5V 3350	15J 8509		
		5V 3550	15J 9017		

<p>Maximum production length: 4250 mm L_o Non-standard length ranges from 1800 mm L_o Minimum order quantity for special length ranges: 9 pieces with 5 ribs or 12 pieces with 4 ribs or 16 pieces with 3 ribs or 24 pieces with 2 ribs or or a multiple thereof Weight: per rib \approx 0.102 kg/m Minimum order quantity for design with aramid tension cord on request</p>	<p>Maximum production length: 10 000 mm L_o Non-standard length ranges from 1800 mm L_o Minimum order quantity for special length ranges: 6 pieces with 5 ribs or 7 pieces with 4 ribs or 10 pieces with 3 ribs or 15 pieces with 2 ribs or or a multiple thereof Weight: per rib \approx 0.252 kg/m Minimum order quantity for design with aramid tension cord on request</p>	<p>Maximum standard production length: 15 000 mm L_o Over 15 000 to 18 000 mm on request Non-standard length ranges from 2540 mm L_o Minimum order quantity for all sizes: 2 pieces with 5 ribs or 2 pieces with 4 ribs or 3 pieces with 3 ribs or or a multiple thereof Weight: per rib \approx 0.693 kg/m Minimum order quantity for design with aramid tension cord on request</p>
---	--	---

Further sizes on request

STANDARD RANGE

optibelt **SUPER KBX-POWER** KRAFTBANDS – RAW EDGE, MOULDED COGGED USA STANDARD RMA/MPTA

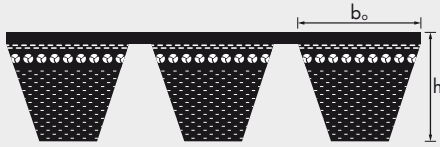

Profile	3VX/9JX	5VX/15JX
$b_o \approx$ [mm]	9.0	15.0
$h \approx$ [mm]	9.9	15.1

Profile 3VX/9JX		Profile 5VX/15JX	
Belt designation		Belt designation	
Profile, length code	Profile, outside length, L_o [mm]	Profile, length code	Profile, outside length, L_o [mm]
3VX 500	9JX 1270	5VX 500	15JX 1270
3VX 530	9JX 1346	5VX 530	15JX 1346
3VX 560	9JX 1422	5VX 560	15JX 1422
3VX 600	9JX 1524	5VX 600	15JX 1524
3VX 630	9JX 1600	5VX 630	15JX 1600
3VX 670	9JX 1702	5VX 670	15JX 1702
3VX 710	9JX 1803	5VX 710	15JX 1803
3VX 750	9JX 1905	5VX 750	15JX 1905
3VX 800	9JX 2032	5VX 800	15JX 2032
3VX 850	9JX 2159	5VX 850	15JX 2159
3VX 900	9JX 2286	5VX 900	15JX 2286
3VX 950	9JX 2413	5VX 950	15JX 2413
3VX 1000	9JX 2540	5VX 1000	15JX 2540
3VX 1060	9JX 2692	5VX 1060	15JX 2692
3VX 1120	9JX 2845	5VX 1120	15JX 2845
3VX 1180	9JX 2997	5VX 1180	15JX 2997
3VX 1250	9JX 3175	5VX 1250	15JX 3175
3VX 1320	9JX 3353	5VX 1320	15JX 3353
3VX 1400	9JX 3556	5VX 1400	15JX 3556

Kraftbands in profiles XPZ, XPA, XPB, AX/HAX and BX/HBX available on request.

Weight: per rib \approx 0.117 kg/m	Weight: per rib \approx 0.241 kg/m
--------------------------------------	--------------------------------------

Further sizes on request

STANDARD RANGE

optibelt **KB** KRAFTBANDS WITH CLASSIC V-BELTS

DIN/ISO, ASAE



Profile	A/HA	B/HB	C/HC	D/HD	E*
$b_o \approx$ [mm]	13.0	17.0	22.0	32.0	40.0
$h \approx$ [mm]	9.9	13.0	16.2	22.4	25.0

* available on request

Profile A/HA			Profile B/HB					Profile C/HC			Profile D/HD			
(Profile A) Inside length		(Profile HA) Outside length L_o [mm]	(Profile B) Inside length		(Profile HB) Outside length L_o [mm]	(Profile B) Inside length		(Profile HB) Outside length L_o [mm]	(Profile C) Inside length		(Profile HC) Outside length L_o [mm]	(Profile D) Inside length		(Profile HD) Outside length L_o [mm]
Belt no.	L_i [mm]		Belt no.	L_i [mm]		Belt no.	L_i [mm]		Belt no.	L_i [mm]		Belt no.	L_i [mm]	
47	1200	1236	47	1200	1262	146	3700	3762	90	2286	2361	98	2500	2611
51	1300	1336	51	1300	1362	148	3750	3812	98	2500	2575	110	2800	2911
56	1422	1458	55	1400	1462	158	4000	4062	108	2750	2825	120	3048	3159
57	1450	1486	59	1500	1562	167	4250	4312	120	3048	3123	128	3250	3361
59	1500	1536	61	1550	1612	177	4500	4562	128	3250	3325	144	3658	3769
64	1625	1661	63	1600	1662	187	4750	4812	140	3550	3625	158	4000	4111
67	1700	1736	64	1625	1687	197	5000	5062	146	3700	3775	162	4115	4226
71	1800	1836	67	1700	1762	208	5300	5362	151	3850	3925	173	4394	4505
75	1900	1936	71	1800	1862	220	5600	5662	167	4250	4325	180	4572	4683
79	2000	2036	73	1850	1912				177	4500	4575	195	4953	5064
88	2240	2276	75	1900	1962				187	4750	4825	210	5334	5445
98	2500	2536	79	2000	2062				197	5000	5075	225	5715	5826
100	2540	2576	83	2100	2162				208	5300	5375	240	6096	6207
104	2650	2686	88	2240	2302				220	5600	5675	255	6477	6588
112	2845	2881	91	2300	2362				236	6000	6075	270	6858	6969
120	3048	3084	94 ^{1/2}	2400	2462				248	6300	6375	285	7239	7350
128	3250	3286	98	2500	2562							300	7620	7731
144	3658	3694	102	2600	2662							315	8000	8111
158	4000	4036	106	2700	2762							330	8382	8493
167	4250	4286	112	2845	2907							345	8763	8874
187	4750	4786	118	3000	3062							360	9144	9255
			120	3048	3110							390	9906	10017
			128	3250	3312							420	10668	10779
			132	3350	3412							450	11430	11541
			140	3550	3612							480	12200	12311
												540	13716	13827
												600	15240	15351
												660	16764	16875
												700	17780	17891

Maximum production length: 10000 mm L_i
 Non-standard length ranges from 1800 mm
 Minimum order quantity for special length ranges from: 1200 to 2000 mm
 6 pieces with 5 ribs or 8 pieces with 4 ribs or 10 pieces with 3 ribs or 16 pieces with 2 ribs or a multiple thereof
 2001 to 8000 mm
 6 pieces with 5 ribs or 8 pieces with 4 ribs or 11 pieces with 3 ribs or 16 pieces with 2 ribs or a multiple thereof
 Weight: per rib \approx 0.163 kg/m
 Minimum order quantity for design with aramid tension cord on request

Maximum production length: 18000 mm L_i
 Non-standard length ranges from 1800 mm
 Minimum order quantity for special length ranges from: 5 pieces with 5 ribs or 6 pieces with 4 ribs or 9 pieces with 3 ribs or 13 pieces with 2 ribs or a multiple thereof
 Weight: per rib \approx 0.266 kg/m
 Minimum order quantity for design with aramid tension cord on request

Maximum production length: 18000 mm L_i
 Non-standard length ranges from 2286 mm
 Minimum order quantity for special length ranges from: 2286 to 10000 mm
 4 pieces with 5 ribs or 5 pieces with 4 ribs or 6 pieces with 3 ribs or 10 pieces with 2 ribs or a multiple thereof
 10001 to 12000 mm
 3 pieces with 5 ribs or 4 pieces with 4 ribs or 5 pieces with 3 ribs or 8 pieces with 2 ribs or a multiple thereof
 Weight: per rib \approx 0.447 kg/m
 Minimum order quantity for design with aramid tension cord on request

Maximum production length: 18000 mm L_i
 Non-standard length ranges from 2500 mm
 Minimum order quantity for all sizes:
 2 pieces with 5 ribs or 2 pieces with 4 ribs or 3 pieces with 3 ribs or 5 pieces with 2 ribs or a multiple thereof
 Weight: per rib \approx 0.798 kg/m
 Minimum order quantity for design with aramid tension cord on request

Further sizes on request

STANDARD RANGE

optibelt **SUPER X-POWER M=S** WEDGE BELTS – RAW EDGE, MOULDED COGGED DIN 7753 PART 1 / ISO 4184 AND RMA/MPTA

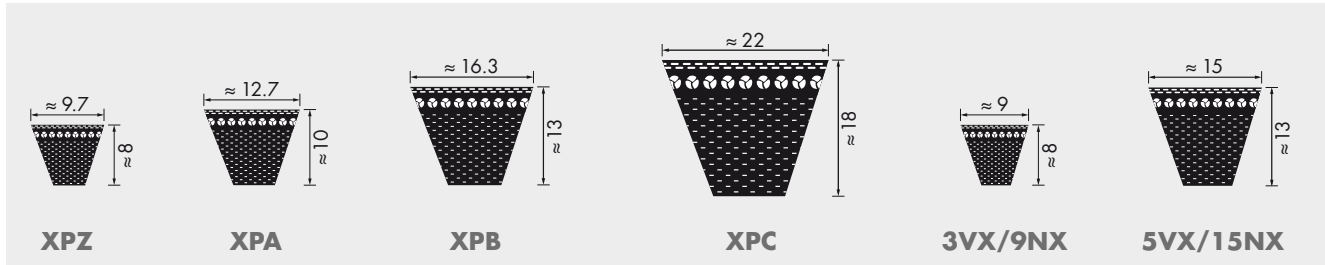

Profile XPZ			Profile XPA		Profile XPB	Profile XPC	Profile 3VX/9NX		Profile 5VX/15NX	
Datum length ISO L_d [mm]			Datum length ISO L_d [mm]		Datum length ISO L_d [mm]	Datum length ISO L_d [mm]	Belt designation		Belt designation	
							Profile, length code	Profile, outside length, L_o [mm]	Profile, length code	Profile, outside length, L_o [mm]
587	1112	1900	707	1432	1250	2000	3VX 250	9NX 635	5VX 500	15NX 1270
612	1120	1950	732	1450	1320	2120	3VX 265	9NX 673	5VX 530	15NX 1346
630	1137	2000	757	1457	1400	2240	3VX 280	9NX 711	5VX 560	15NX 1422
637	1162	2120	782	1482	1500	2360	3VX 300	9NX 762	5VX 600	15NX 1524
662	1180	2150	800	1500	1600	2500	3VX 315	9NX 800	5VX 630	15NX 1600
670	1187	2240	807	1507	1700	2650	3VX 335	9NX 851	5VX 670	15NX 1702
687	1202	2360	832	1532	1750	2800	3VX 355	9NX 902	5VX 710	15NX 1803
710	1212	2500	850	1557	1800	3000	3VX 375	9NX 952	5VX 750	15NX 1905
730	1237	2540	857	1582	1850	3150	3VX 400	9NX 1016	5VX 800	15NX 2032
737	1250	2650	882	1600	1900	3350	3VX 425	9NX 1079	5VX 850	15NX 2159
750	1262	2690	900	1607	2000	3550	3VX 450	9NX 1143	5VX 900	15NX 2286
762	1287	2800	907	1632	2020		3VX 475	9NX 1206	5VX 950	15NX 2413
772	1312	2840	932	1650	2120		3VX 500	9NX 1270	5VX 1000	15NX 2540
787	1320	3000	950	1682	2150		3VX 530	9NX 1346	5VX 1060	15NX 2692
800	1337	3150	957	1700	2240		3VX 560	9NX 1422	5VX 1120	15NX 2845
812	1362	3350	982	1732	2280		3VX 600	9NX 1524	5VX 1180	15NX 2997
825	1387	3550	1000	1750	2360		3VX 630	9NX 1600	5VX 1250	15NX 3175
837	1400		1007	1757	2400		3VX 670	9NX 1702	5VX 1320	15NX 3353
850	1412		1030	1782	2500		3VX 710	9NX 1803	5VX 1400	15NX 3556
862	1437		1060	1800	2650		3VX 750	9NX 1905		
875	1462		1082	1832	2680		3VX 800	9NX 2032		
887	1487		1107	1850	2800		3VX 850	9NX 2159		
900	1500		1120	1882	2840		3VX 900	9NX 2286		
912	1512		1132	1900	3000		3VX 950	9NX 2413		
925	1537		1157	1932	3150		3VX 1000	9NX 2540		
937	1562		1180	1950	3350		3VX 1060	9NX 2692		
950	1587		1207	1982	3550		3VX 1120	9NX 2845		
962	1600		1232	2000			3VX 1180	9NX 2997		
987	1612		1250	2120			3VX 1250	9NX 3175		
1000	1662		1257	2240			3VX 1320	9NX 3353		
1012	1700		1272	2360			3VX 1400	9NX 3556		
1037	1750		1282	2500						
1060	1762		1307	2650						
1077	1800		1320	2800						
1087	1850		1332	3000						
			1357	3150						
			1382	3350						
			1400	3550						
Weight: ≈ 0.065 kg/m			Weight: ≈ 0.096 kg/m		Weight: ≈ 0.183 kg/m	Weight: ≈ 0.340 kg/m	Weight: ≈ 0.065 kg/m		Weight: ≈ 0.183 kg/m	

Datum length $L_d \triangleq$ Pitch length L_w/L_p Further sizes on request

STANDARD RANGE

optibelt **SUPER E-POWER M=S** WEDGE BELTS – RAW EDGE, MOULDED COGGED DIN 7753 PART 1 / ISO 4184 AND RMA/MPTA

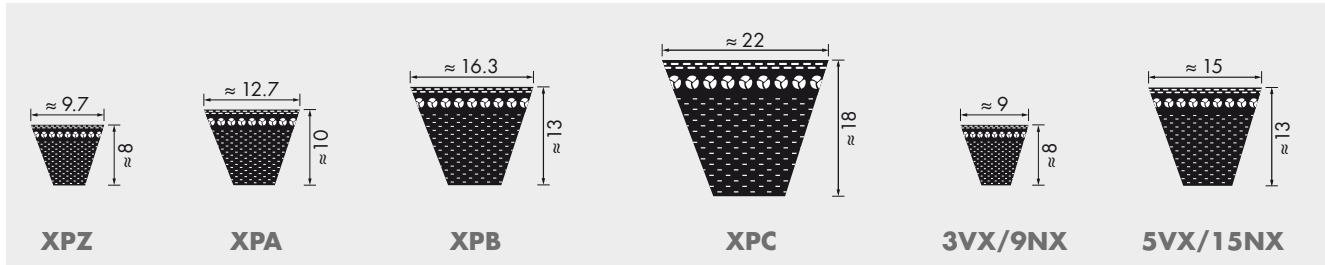

Profile XPZ			Profile XPA		Profile XPB	Profile XPC	Profile 3VX/9NX		Profile 5VX/15NX	
Datum length ISO L_d [mm]			Datum length ISO L_d [mm]		Datum length ISO L_d [mm]	Datum length ISO L_d [mm]	Belt designation		Belt designation	
							Profile, length code	Profile, outside length, L_o [mm]	Profile, length code	Profile, outside length, L_o [mm]
587	1112	1900	707	1432	1250	2000	3VX 250	9NX 635	5VX 500	15NX 1270
612	1120	1950	732	1450	1320	2120	3VX 265	9NX 673	5VX 530	15NX 1346
630	1137	2000	757	1457	1400	2240	3VX 280	9NX 711	5VX 560	15NX 1422
637	1162	2120	782	1482	1500	2360	3VX 300	9NX 762	5VX 600	15NX 1524
662	1180	2150	800	1500	1600	2500	3VX 315	9NX 800	5VX 630	15NX 1600
670	1187	2240	807	1507	1700	2650	3VX 335	9NX 851	5VX 670	15NX 1702
687	1202	2360	832	1532	1750	2800	3VX 355	9NX 902	5VX 710	15NX 1803
710	1212	2500	850	1557	1800	3000	3VX 375	9NX 952	5VX 750	15NX 1905
730	1237	2540	857	1582	1850	3150	3VX 400	9NX 1016	5VX 800	15NX 2032
737	1250	2650	882	1600	1900	3350	3VX 425	9NX 1079	5VX 850	15NX 2159
750	1262	2690	900	1607	2000	3550	3VX 450	9NX 1143	5VX 900	15NX 2286
762	1287	2800	907	1632	2020		3VX 475	9NX 1206	5VX 950	15NX 2413
772	1312	2840	932	1650	2120		3VX 500	9NX 1270	5VX 1000	15NX 2540
787	1320	3000	950	1682	2150		3VX 530	9NX 1346	5VX 1060	15NX 2692
800	1337	3150	957	1700	2240		3VX 560	9NX 1422	5VX 1120	15NX 2845
812	1362	3350	982	1732	2280		3VX 600	9NX 1524	5VX 1180	15NX 2997
825	1387	3550	1000	1750	2360		3VX 630	9NX 1600	5VX 1250	15NX 3175
837	1400		1007	1757	2400		3VX 670	9NX 1702	5VX 1320	15NX 3353
850	1412		1030	1782	2500		3VX 710	9NX 1803	5VX 1400	15NX 3556
862	1437		1060	1800	2650		3VX 750	9NX 1905		
875	1462		1082	1832	2680		3VX 800	9NX 2032		
887	1487		1107	1850	2800		3VX 850	9NX 2159		
900	1500		1120	1882	2840		3VX 900	9NX 2286		
912	1512		1132	1900	3000		3VX 950	9NX 2413		
925	1537		1157	1932	3150		3VX 1000	9NX 2540		
937	1562		1180	1950	3350		3VX 1060	9NX 2692		
950	1587		1207	1982	3550		3VX 1120	9NX 2845		
962	1600		1232	2000			3VX 1180	9NX 2997		
987	1612		1250	2120			3VX 1250	9NX 3175		
1000	1662		1257	2240			3VX 1320	9NX 3353		
1012	1700		1272	2360			3VX 1400	9NX 3556		
1037	1750		1282	2500						
1060	1762		1307	2650						
1077	1800		1320	2800						
1087	1850		1332	3000						
			1357	3150						
			1382	3350						
			1400	3550						
Weight: ≈ 0.062 kg/m			Weight: ≈ 0.091 kg/m		Weight: ≈ 0.174 kg/m	Weight: ≈ 0.323 kg/m	Weight: ≈ 0.062 kg/m		Weight: ≈ 0.147 kg/m	

Datum length $L_d \triangleq$ Pitch length L_w/L_p Further sizes on request

STANDARD RANGE

optibelt **SUPER TX M=S** V-BELTS – RAW EDGE, MOULDED COGGED DIN 2215 / ISO 4184

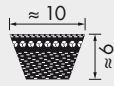

ZX/X10

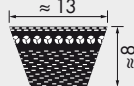

AX/X13

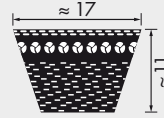

BX/X17

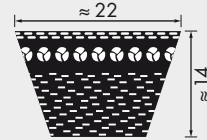

CX/X22

Profile ZX/X10		Profile AX/X13				Profile BX/X17				Profile CX/X22	
Belt no.	Datum length ISO L_d [mm]	Belt no.	Datum length ISO L_d [mm]	Belt no.	Datum length ISO L_d [mm]	Belt no.	Datum length ISO L_d [mm]	Belt no.	Datum length ISO L_d [mm]	Belt no.	Datum length ISO L_d [mm]
ZX 23	597	AX 23	605	AX 62	1605	BX 23	610	BX 67	1740	CX 39	1058•
ZX 24	622	AX 23½	630	AX 63	1630	BX 25	670	BX 69	1790	CX 43	1148•
ZX 25	652	AX 24	640	AX 67	1730	BX 26	690	BX 71	1840	CX 49	1308•
ZX 26	672	AX 25	660	AX 70	1805	BX 28	750	BX 73	1890	CX 52	1378•
ZX 27	692	AX 26½	700	AX 71	1830	BX 29	765	BX 75	1940	CX 55	1458•
ZX 28	732	AX 27	716	AX 75	1930	BX 30	790	BX 79	2040	CX 59	1558•
ZX 29	752	AX 28	740	AX 79	2030	BX 31	815	BX 88	2280	CX 62	1632•
ZX 29½	772	AX 29	760	AX 88	2270	BX 32	840	BX 93	2400	CX 67	1758•
ZX 31½	822	AX 30	797	AX 93	2390	BX 33	876	BX 98	2540	CX 68	1785•
ZX 32	842	AX 31	805	AX 98	2530•	BX 34	890	BX 103	2656•	CX 71	1858•
ZX 33	847	AX 32	843	AX 104	2680•	BX 34½	915	BX 104	2690•	CX 75	1958•
ZX 33½	872	AX 33	871	AX 110	2830•	BX 35	929	BX 110	2840•	CX 79	2058•
ZX 35	897	AX 34	880	AX 118	3030•	BX 36	940	BX 118	3040•	CX 81	2118•
ZX 36	922	AX 35	919	AX 124	3180•	BX 37	965	BX 124	3190•	CX 85	2217•
ZX 37	947	AX 35½	930	AX 132	3380•	BX 38	1005	BX 132	3390•	CX 88	2298•
ZX 38	972	AX 36	944			BX 39	1040			CX 90	2344•
ZX 40	1038•	AX 37	955			BX 40	1056			CX 93	2418•
ZX 42	1082•	AX 37½	980			BX 41	1080			CX 96	2496•
ZX 46½	1202•	AX 38	995			BX 42	1100			CX 98	2558•
ZX 52	1342•	AX 39	1030			BX 43	1130			CX 110	2858•
ZX 55	1422•	AX 40	1046			BX 44	1160			CX 118	3058•
ZX 59	1522•	AX 41½	1080			BX 45	1190			CX 124	3208•
		AX 42	1090			BX 45½	1203			CX 132	3408•
		AX 43	1130			BX 46	1215				
		AX 44	1150			BX 46½	1220				
		AX 45½	1180			BX 47	1240				
		AX 46	1198			BX 48	1255				
		AX 47	1230			BX 49	1290				
		AX 48	1250			BX 50	1315				
		AX 49	1280			BX 51	1340				
		AX 50	1300			BX 52	1360				
		AX 51	1330			BX 53	1390				
		AX 52	1350			BX 54	1412				
		AX 53	1380			BX 55	1440				
		AX 54	1405			BX 57	1490				
		AX 55	1430			BX 58	1513				
		AX 56	1452			BX 59	1540				
		AX 57	1480			BX 61	1590				
		AX 58	1505			BX 62	1615				
		AX 59	1530			BX 63	1640				
Weight: ≈ 0.062 kg/m		Weight: ≈ 0.099 kg/m				Weight: ≈ 0.165 kg/m				Weight: ≈ 0.276 kg/m	
Datum length $L_d \triangleq$ Pitch length L_w/L_p Further sizes on request • Non stock items											

STANDARD RANGE

optibelt **VARIO POWER** VARIABLE SPEED BELTS – RAW EDGE, MOULDED COGGED DIN 7719 / ISO 1604



Profile/ inside length L _i [mm]	ISO designation (datum length) L _d	Profile/ inside length L _i [mm]	ISO designation (datum length) L _d	Profile/ inside length L _i [mm]	ISO designation (datum length) L _d	Profile/ inside length L _i [mm]	ISO designation (datum length) L _d	Profile/ inside length L _i [mm]	ISO designation (datum length) L _d
13 x 5		26 x 8		32 x 10		47 x 13		70 x 18	
468		655	W 25 690	750	W 31,5 800	1000		1600	
500		672	W 25 710	790	W 31,5 840	1060		1700	
		710	W 25 750	820	W 31,5 870	1120		1800	
17 x 5		750	W 25 790	850	W 31,5 900	1180		1900	
426	W 16 450	762	W 25 800	900	W 31,5 950	1250		2000	
476	W 16 500	800	W 25 840	950	W 31,5 1000	1320		2240	
536	W 16 560	862	W 25 900	1000	W 31,5 1050	1400		2500	
570	W 16 600	962	W 25 1000	1073	W 31,5 1120	1500			
606	W 16 630	1082	W 25 1120	1120	W 31,5 1170	1600			
776	W 16 800			1180	W 31,5 1230	1700			
		28 x 8		1200	W 31,5 1250	1800			
21 x 6		600		1353	W 31,5 1400				
530	W 20 560	650				52 x 16			
600	W 20 630	700				1180	W 50 1250		
610	W 20 640	750		37 x 10		1250	W 50 1320		
675	W 20 710	800		660		1325	W 50 1400		
770	W 20 800	850		800		1400	W 50 1480		
870	W 20 900	900		850		1525	W 50 1600		
970	W 20 1000	950		900		1600	W 50 1680		
1220	W 20 1250	1000		950		1725	W 50 1800		
		1060		1000		1925	W 50 2000		
22 x 8		1120		1020		2165	W 50 2240		
485		1180		1060		2240	W 50 2320		
525		1250		1120					
565		1320		1180		55 x 16			
650		1400		1250		1400			
700		1500		1320		1500			
750				1400		1600			
800		30 x 10		1500		1700			
850		650		1600		1800			
900		665		1700					
950		700		1800		65 x 20			
1000		800				1706	W 63 1800		
1060		850		41 x 13		1906	W 63 2000		
1185		875		925	W 40 990				
		900		1000	W 40 1060				
		950		1040	W 40 1100				
		1000		1060	W 40 1120				
		1035		1120	W 40 1180				
		1120		1180	W 40 1240				
		1200		1190	W 40 1250				
		1340		1250	W 40 1310				
		1500		1340	W 40 1400				
		1600		1440	W 40 1500				
				1600	W 40 1660				
				1740	W 40 1800				
				1940	W 40 2000				

Standard production data

Belt length up to 5000 mm L_i

Belt top width up to 100 mm

Belt height 5 to 25 mm

24° angle for profile 13 x 5; 17 x 5

30° angle for profile 52 x 16; 55 x 16; 65 x 20 and 70 x 18

27° angle for all other profiles. Sizes according to USA standard RMA/MPTA as well as variable speed belts with angles from 22° to 42° can be produced on request. Minimum order quantities are required.

Further sizes as well as double-cogged variable speed belts on request

Tolerances

Length tolerance ± 1 % of the belt nominal length

Angle tolerance ± 1.5° of the nominal angle

Height tolerance ≤ 8 mm = ± 0.8 mm

> 8 to 20 mm = ± 1.0 mm

> 20 mm = ± 1.5 mm

Width tolerance ± 0.75 mm

STANDARD RANGE

optibelt **VARIO POWER** VARIABLE SPEED BELTS – RAW EDGE, MOULDED COGGED USA STANDARD RMA/MPTA



RMA/MPTA designation	RMA/MPTA designation	RMA/MPTA designation	RMA/MPTA designation
1422 V 235•	1922 V 751•	2530 V 934•	3230 V 630•
1422 V 240•	1922 V 756•	2530 V 990•	3230 V 670•
1422 V 270•			3230 V 710•
1422 V 290•	1926 V 250•	2830 V 337•	3230 V 723•
1422 V 300•	1926 V 275•	2830 V 363•	3230 V 750•
	1926 V 290•	2830 V 366•	
1422 V 330•	1926 V 407•	2830 V 367•	3230 V 800•
1422 V 340•	1926 V 415•	2830 V 393•	3230 V 850•
1422 V 360•			
1422 V 400•	1926 V 427•	2830 V 396•	3432 V 450•
1422 V 420•		2830 V 422•	3432 V 456•
			3432 V 480•
1422 V 440•	2230 V 266•	2926 V 471•	3432 V 528•
1422 V 460•	2230 V 273•	2926 V 486•	3432 V 534•
1422 V 470•	2230 V 275•	2926 V 521•	
1422 V 480•	2230 V 326•	2926 V 546•	4036 V 541•
1422 V 540•	2230 V 375•	2926 V 574•	4036 V 574•
1422 V 600•	2322 V 329•	2926 V 586•	4430 V 530•
1422 V 660•	2322 V 347•	2926 V 606•	4430 V 548•
	2322 V 364•	2926 V 616•	4430 V 555•
1430 V 215•	2322 V 396•	2926 V 636•	4430 V 560•
	2322 V 421•	2926 V 646•	4430 V 570•
1922 V 277•	2322 V 434•	2926 V 666•	4430 V 578•
1922 V 282•	2322 V 441•	2926 V 686•	4430 V 600•
1922 V 298•	2322 V 461•	2926 V 726•	4430 V 610•
1922 V 321•	2322 V 481•	2926 V 750•	4430 V 630•
1922 V 332•	2322 V 486•	2926 V 776•	4430 V 652•
1922 V 338•	2322 V 521•	2926 V 786•	4430 V 660•
1922 V 363•	2322 V 541•		4430 V 670•
1922 V 381•	2322 V 601•	3226 V 392•	4430 V 690•
1922 V 386•	2322 V 661•	3226 V 400•	4430 V 700•
1922 V 403•	2322 V 681•	3226 V 433•	4430 V 710•
		3226 V 450•	
1922 V 426•	2322 V 701•	3226 V 505•	4430 V 730•
1922 V 443•	2322 V 801•		4430 V 750•
1922 V 454•		3226 V 545•	4430 V 790•
1922 V 460•	2426 V 353•	3226 V 585•	4430 V 800•
1922 V 484•	2426 V 363•	3226 V 603•	4430 V 850•
		3226 V 650•	
1922 V 526•		3226 V 663•	
1922 V 544•	2530 V 500•		4436 V 525•
1922 V 604•	2530 V 530•	3226 V 723•	4436 V 551•
1922 V 630•	2530 V 560•	3226 V 783•	4436 V 561•
1922 V 646•	2530 V 600•	3226 V 843•	4436 V 576•
	2530 V 630•		4436 V 646•
1922 V 666•			
1922 V 686•	2530 V 670•	3230 V 419•	4436 V 750•
1922 V 706•	2530 V 710•	3230 V 528•	
1922 V 721•	2530 V 750•	3230 V 560•	
1922 V 726•	2530 V 790•	3230 V 585•	
	2530 V 800•	3230 V 600•	

Explanation (e.g. 1422 V 235)
 14 = top width 14/16"
 22 = angle
 V = variable speed
 235 = pitch length in 1/10"

• Non-stock item – Minimum order quantity on request. Further sizes as well as double-cogged variable speed belts on request.

STANDARD RANGE

optibelt **DK** DOUBLE-SIDED V-BELTS

DIN/ISO, ASAE

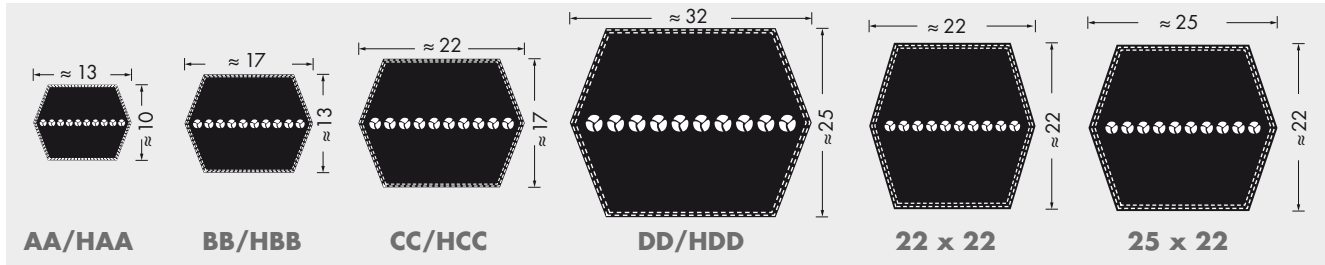

Profile AA/HAA		Profile BB/HBB				Profile CC/HCC		Profile DD/HDD	
Reference length [mm]	Belt no.	Reference length [mm]	Belt no.	Reference length [mm]	Belt no.	Reference length [mm]	Belt no.	Reference length [mm]	Belt no.
2000	77	1980	75	4040	156	2280	86	on request	
2032	78	2180	83	4200	162	2500	94		
2370	91	2300	88	4470	173	2800	106		
2500	96	2370	90	4500	174	3200	122		
2650	102	2500	95	4750	184	3310	126		
2667	103	2540	97	5000	194	3765	144		
2800	108	2600	99	5639	221	4000	153		
3300	128	2650	101			4216	162	Weight: ≈ 0.935 kg/m	
3920	152	2740	105			4300	165		
		2800	107			4500	173		
		2850	109			5000	193	Profile 22 x 22	
		2920	112			5300	204		
		3000	115			5340	206	5180	
		3030	116			5750	224	5220	
		3150	121					5850	
		3250	125					6270	
		3280	126						
		3325	128						
		3390	131					Weight: ≈ 0.511 kg/m	
		3450	133						
		3500	135					Profile 25 x 22	
		3550	137						
		3730	144						
		3750	145					on request	
		4010	155						
Weight: ≈ 0.150 kg/m		Weight: ≈ 0.250 kg/m				Weight: ≈ 0.440 kg/m		Weight: ≈ 0.625 kg/m	

Non-standard length ranges and special constructions:

- Profile AA/HAA 1350 to 6000 mm
- Profile BB/HBB 1350 to 12700 mm
- Profile CC/HCC 1600 to 19500 mm
- Profile DD/HDD on request
- Profile 22 x 22 on request
- Profile 25 x 22 on request

Minimum order quantity for special constructions on request

Conversion factors from the belt number to the reference length:

Profile AA/HAA – Belt no. x 25.4 = mm + 53 mm

Profile BB/HBB – (up to belt no. 210)
Belt no. x 25.4 = mm + 74 mm
(over belt no. 210)
Belt no. x 25.4 = mm + 36 mm

Profile CC/HCC – (up to belt no. 210)
Belt no. x 25.4 = mm + 107 mm
(over belt no. 210)
Belt no. x 25.4 = mm + 56 mm

Profile DD/HDD – (up to belt no. 210)
Belt no. x 25.4 = mm + 132 mm
(over belt no. 210)
Belt no. x 25.4 = mm + 69 mm

PRODUCT DESCRIPTION

optibelt **KS** V-GROOVED PULLEYS – optibelt **TB** TAPER-BUSHES



optibelt KS V-grooved pulleys

optibelt KS V-grooved pulleys are available with pilot bore and for taper bushes in all common belt profiles.



optibelt TB taper bushes

optibelt TB taper bushes are used for easy installations of pulleys on shafts with or without keyway.

PRODUCT DESCRIPTION

optibelt **KS** V-GROOVED PULLEYS, TYPES

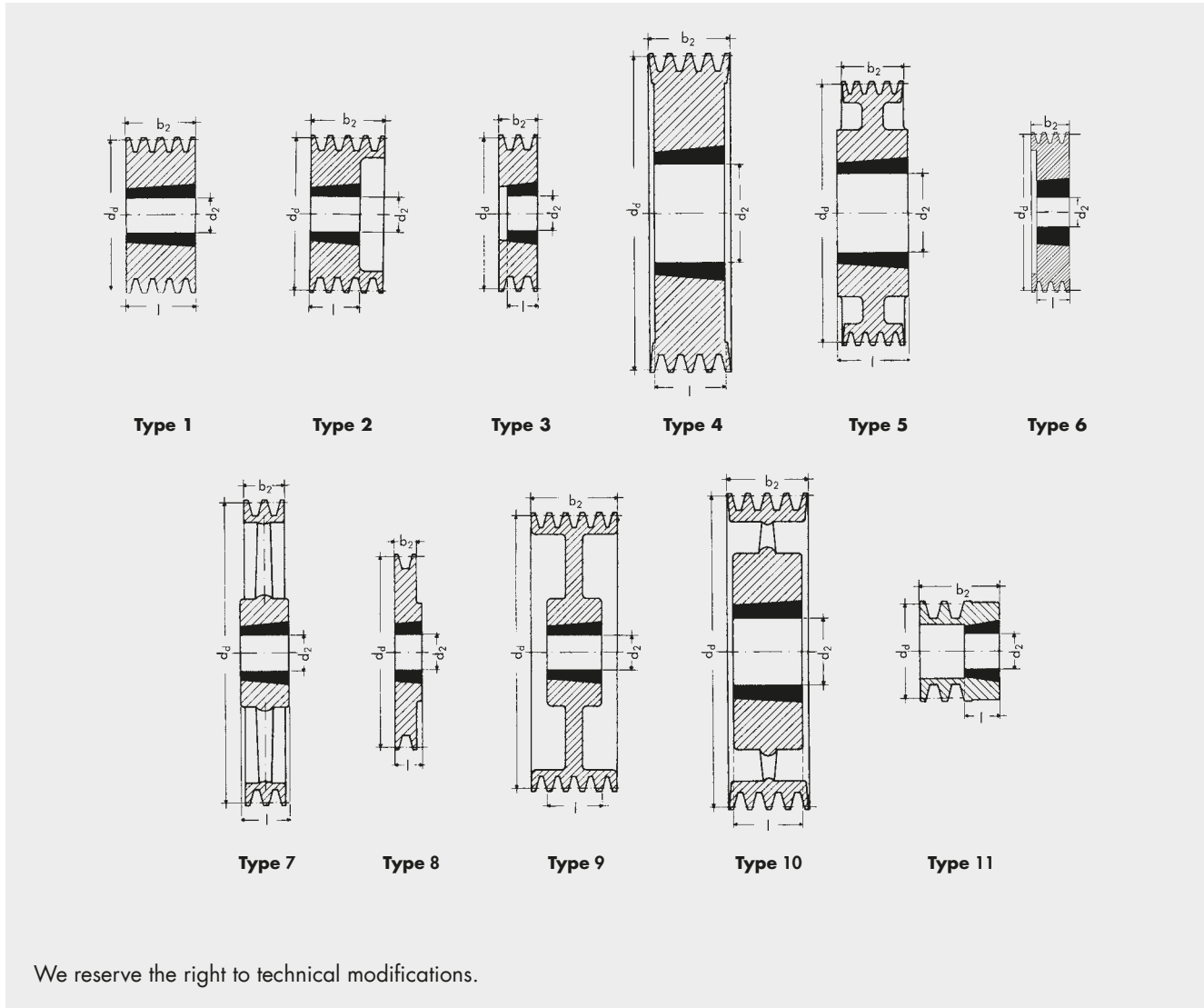

Balancing

V-grooved pulleys are statically balanced in accordance with the guidelines in VDI 2060, as standard: Quality level G 16; for dia. $d_d >$ at $n = 1500$ rpm; for dia. $d_d > 400$ mm at $v = 30$ m/s.

The pulleys are balanced without keys on smooth balancing spindles. Machines whose runners are balanced with a keyway in the shaft end should be ordered as follows: "Balanced with pilot bore and empty keyway on smooth balancing spindles without key."

Balancing in one plane to quality level G 6.3 on request. We recommend balancing in two planes according to quality level G 6.3, or finer when $v > 30$ m/s or the ratio of datum diameter to face width $d_d : b_2$ is < 4 at $v > 20$ m/s. In such cases, the operational speed of the pulley must be given.

Special pulleys and customised pulleys on request

PRODUCT DESCRIPTION

optibelt **KS** V-GROOVED PULLEYS – STANDARDS – DESIGN CRITERIA – TYPES

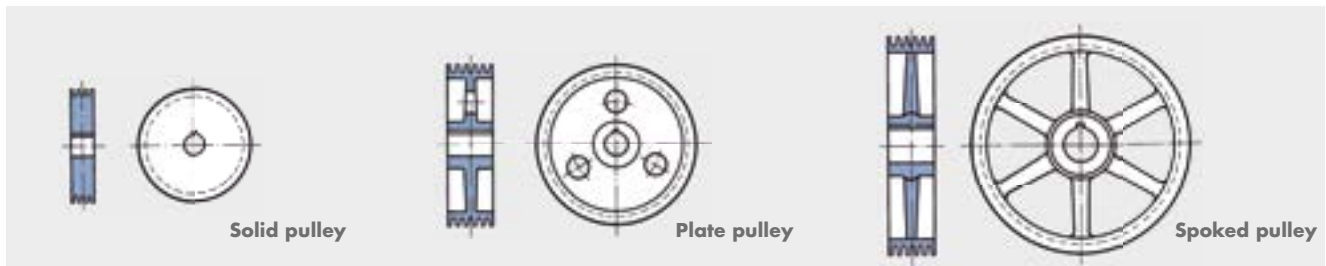

An essential component in V-belt drive systems is the V-belt pulley, or in short V-pulley. They are primarily manufactured from cast iron EN-GJL-200-DIN EN 1561 and are available with a pilot hole, pre-fabricated hole or with a clamping bush system. The DIN standard as well as the most important national pulley standards of all industrial nations are based upon the ISO 4183 standard "Grooved Pulleys for Classic V-Belts and Wedge Belts". V-belt pulleys with grooves for wedge belts according to DIN 7753 Part 1 are also suitable for classic V-belts with the same datum width b_d according to DIN 2215. These are known as dual duty pulleys.

- Balancing in two planes (dynamically), quality level Q 6.3 becomes necessary if:
 1. $v > 30$ m/s or
 2. the ratio of datum diameter to pulley face width $d_d : b_2 < 4$ at $v > 20$ m/s.

Note: The timely replacement of pulleys damaged by corrosion or erosion prevents premature failure of the belts. Furthermore, it is important to prevent the belt basis from direct contact with the groove basis as this can quickly lead to damage and premature failure (exception: special drives such as V-flat drives).

Example

	Belt		Grooved pulleys
Profile	SPZ	Z/10	SPZ – Z/10
Top width	$b_o \approx 9.7$	$b_o \approx 10$	$b_1 \approx 9.7$
Datum width	$b_d = 8.5$		$b_d = 8.5$
Belt height/ groove depth	$h \approx 8$	$h \approx 6$	$t_{min} = 11$

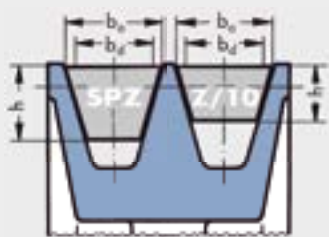

When selecting a pulley, the following criteria should be taken into account:

- Use standard pulley diameters. If design considerations make this impossible, a standard diameter should, as a minimum requirement, be selected for the largest pulley in the drive.
- Do not select a pulley smaller than the recommended size to ensure a longer operational life and overall drive efficiency.
- If manufacturing your own pulleys, the overall shape and processing must conform to the relevant standards.
- Grooved pulleys are generally balanced in one plane (statically) to quality level Q 16 as in VDI 2060.

Deep grooved pulleys

Deep grooved pulleys are employed for special drive situations such as

- the use of guide idlers,
- twist drives or
- drives subject to severe vibration.

The increased groove top width " b_1 " and depth " t " of deep grooved pulleys improves the running characteristics of the belt, particularly when entering the groove. Turning over and running out of the belt are prevented.

Deep grooved pulleys are not suitable for the use with kraftbands.

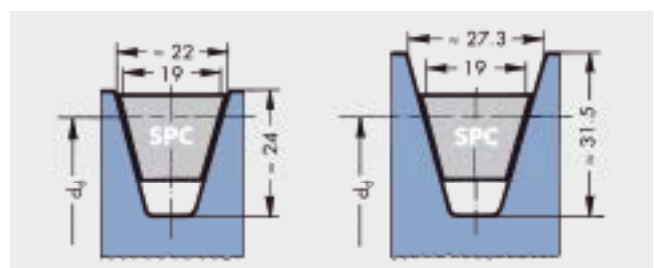

STANDARD RANGE

optibelt **KS** V-GROOVED PULLEYS DIN 2211 SHEET 1 FOR WEDGE BELTS AND DIN 2217 SHEET 1 FOR CLASSIC V-BELTS

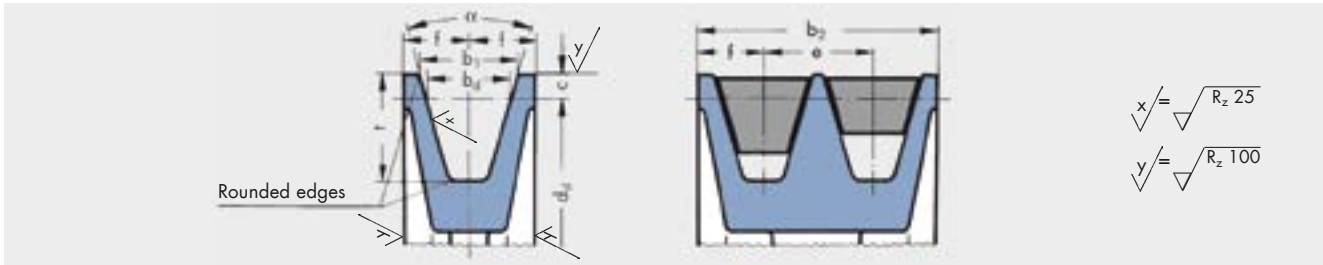

Table 14

V-belt profile	ISO designation	–	Y*	–	Z*	A*	B*	–	C*	–	D	E
Wedge belt profile	DIN 7753 Part 1 and ISO	–	–	–	SPZ*	SPA*	SPB*	–	SPC*	–	–	–
b_d		4.2	5.3	6.7	8.5	11.0	14.0	17.0	19.0	21.0	27.0	32.0
$b_1 \approx$		5.0	6.3	8.0	9.7	12.7	16.3	20.0	22.0	25.0	32.0	40.0
c		1.3	1.6	2.0	2.0	2.8	3.5	5.1	4.8	6.3	8.1	12.0
e		6 ± 0.3	8 ± 0.3	10 ± 0.3	12 ± 0.3	15 ± 0.3	19 ± 0.4	23 ± 0.4	25.5 ± 0.5	29 ± 0.5	37 ± 0.6	44.5 ± 0.7
f		5 ± 0.5	6 ± 0.5	7 ± 0.6	8 ± 0.6	10 ± 0.6	12.5 ± 0.8	15 ± 0.8	17 ± 1.0	19 ± 1.0	24 ± 2.0	29 ± 2.0
t	Endless V-belts	$6 + 0.6$	$7 + 0.6$	$9 + 0.6$	$11 + 0.6$	$14 + 0.6$	$18 + 0.6$	$18 + 0.6$	$24 + 0.6$	$22 + 0.6$	$28 + 0.6$	$33 + 0.6$
	Open-ended V-belts DIN 2216	0	0	0	0	0	0	0	0	0	0	0
$d_{d \text{ min}}$	V-belts	20	28	40	50	71	112	160	180	250	355	500
	Wedge belts	–	–	–	63	90	140	–	224	–	–	–
α		$32^\circ \pm 1^\circ$ $d_d \leq 50$	$32^\circ \pm 1^\circ$ $d_d \leq 63$	$32^\circ \pm 1^\circ$ $d_d \leq 75$	–	–	–	–	–	–	–	–
		–	–	–	$34^\circ \pm 1^\circ$ $d_d \leq 80$	$34^\circ \pm 1^\circ$ $d_d \leq 118$	$34^\circ \pm 1^\circ$ $d_d \leq 190$	$34^\circ \pm 1^\circ$ $d_d \leq 250$	$34^\circ \pm 1^\circ$ $d_d \leq 315$	$34^\circ \pm 1^\circ$ $d_d \leq 355$	–	–
		$36^\circ \pm 1^\circ$ $d_d > 50$	$36^\circ \pm 1^\circ$ $d_d > 63$	$36^\circ \pm 1^\circ$ $d_d > 75$	–	–	–	–	–	–	$36^\circ \pm 30'$ $d_d \leq 500$	$36^\circ \pm 30'$ $d_d \leq 630$
		–	–	–	$38^\circ \pm 1^\circ$ $d_d > 80$	$38^\circ \pm 1^\circ$ $d_d > 118$	$38^\circ \pm 1^\circ$ $d_d > 190$	$38^\circ \pm 1^\circ$ $d_d > 250$	$38^\circ \pm 30'$ $d_d > 315$	$38^\circ \pm 30'$ $d_d > 355$	$38^\circ \pm 30'$ $d_d > 500$	$38^\circ \pm 30'$ $d_d > 630$
Face width b_2 for number of grooves z $b_2 = (z - 1) e + 2 f$		1	10.0	12.0	14.0	16.0	20.0	25.0	30.0	34.0	38.0	48.0
		2	16.0	20.0	24.0	28.0	35.0	44.0	53.0	59.5	67.0	85.0
		3	22.0	28.0	34.0	40.0	50.0	63.0	76.0	85.0	96.0	122.0
		4	28.0	36.0	44.0	52.0	65.0	82.0	99.0	110.5	125.0	159.0
		5	34.0	44.0	54.0	64.0	80.0	101.0	122.0	136.0	154.0	196.0
		6	40.0	52.0	64.0	76.0	95.0	120.0	145.0	161.5	183.0	233.0
		7		60.0	74.0	88.0	110.0	139.0	168.0	187.0	212.0	270.0
		8			84.0	100.0	125.0	158.0	191.0	212.5	241.0	307.0
		9				112.0	140.0	177.0	214.0	238.0	270.0	344.0
		10					155.0	196.0	237.0	263.5	299.0	381.0
		11						215.0	260.0	289.0	328.0	418.0
		12							283.0	314.5	357.0	455.0

* These V-grooved pulleys are also suitable for SUPER TX M=S V-belts, SUPER E-POWER M=S and SUPER X-POWER M=S.

STANDARD RANGE

optibelt **KS** V-GROOVED PULLEYS DIN 2211 SHEET 1 FOR WEDGE BELTS AND DIN 2217 SHEET 1 FOR CLASSIC V-BELTS

Table 15

V-belt profile	ISO designation	-	Y	-	Z	A	B	-	C	-	D	E	Datum diameter d_d		Radial and axial run-out tolerance
	DIN 2215	5	6	8	10	13	17	20	22	25	32	40	min.	max.	
Wedge belt profile	DIN 7753 Part 1 and ISO 4184	-	-	-	SPZ	SPA	SPB	-	SPC	-	-	-	min.	max.	Radial and axial run-out tolerance
Datum diameter d_d	20.0												20.0	20.4	
	22.0												22.0	22.4	
	25.0												25.0	25.4	
	28.0	28.0											28.0	28.4	
	31.5	31.5											31.5	32.0	
	35.5	35.5											35.5	36.1	
	40.0	40.0	40		40								40.0	40.6	
	45.0	45.0	45		45								45.0	45.7	
	50.0	50.0	50		50								50.0	50.8	
	56.0	56.0	56		56								56.0	56.9	
	63.0	63.0	63		63	63							63.0	64.0	
					67	67							67.0	68.0	
	71.0	71.0	71		71	71							71.0	72.1	
	80.0	80.0	80		80	80							80.0	81.3	
			85		85	85						85.0	86.3		
		90.0	90		90	90	90						90.0	91.4	
		100.0	95		95	95	95	95					95.0	96.4	
			100		100	100	100	100					100.0	101.6	
					106	106	106						106.0	107.6	
	0.3	112.0	112		112	112	112							112.0	113.8
125.0		118		118	118	118							118.0	119.9	
		125		125	125	125							125.0	127.0	
		132		132	132	132							132.0	134.1	
		140		140	140	140							140.0	142.2	
		150		150	150	150							150.0	152.4	
		160		160	160	160	160		140	150	160		160.0	162.6	
		180		170	170	170	180		180				170.0	172.7	
200		180		180	180	180	180		180				180.0	182.9	
		190		190	190	190	200		190				190.0	193.0	
	200		200	200	200	200		200				200.0	203.2		
	212		212	212	212	224		212				212.0	215.4		
	224		224	224	224	224		224				224.0	227.6		
				225	225			225				225.0	228.6		
				236	236			236				236.0	239.8		
				250	250	250		250	250			250.0	254.0		
						265		265				265.0	269.0		
0.4				280	280	280	280	280	280				280.0	284.5	
				300	300	300		300					300.0	304.8	
				315	315	315	315	315	315				315.0	320.0	
				335	335	335		335					335.0	340.0	
				355	355	355	355	355	355	355			355.0	360.7	
0.5				375	375	375		375					375.0	380.7	
				400	400	400	400	400	400	400			400.0	406.4	
				425	425	425		425					425.0	431.4	
				450	450	450	450	450	450	450			450.0	457.2	
				475	475	475		475					475.0	482.2	
0.6				500	500	500	500	500	500	500	500		500.0	508.0	
				560	560	560	560	560	560	560	560		560.0	569.0	
				630	630	630	630	630	630	630	630		630.0	640.1	
				710	710	710		710					710.0	721.4	
0.8				800	800	800	800	800	800	800	800		800.0	812.8	
				900	900	900	900	900	900	900	900		900.0	914.4	
				1000	1000	1000	1000	1000	1000	1000	1000		1000.0	1016.0	
1.0															
1.2															
Allowed deviation of the datum diameters of the grooves in relation to one another [mm]	0.3			0.4			0.6					—			

For further details see standard DIN 2211 Page 1 and DIN 2217 Page 1. These V-grooved pulleys are also suitable optibelt SUPER TX and SUPER X-POWER M=S V-belts. Preferred datum diameters in **bold** type. ■ Only for classic V-belts, raw edge • For optibelt SUPER X-POWER M=S wedge belts

STANDARD RANGE

optibelt **KS** V-GROOVED PULLEYS USA STANDARD RMA/MPTA FOR WEDGE BELTS

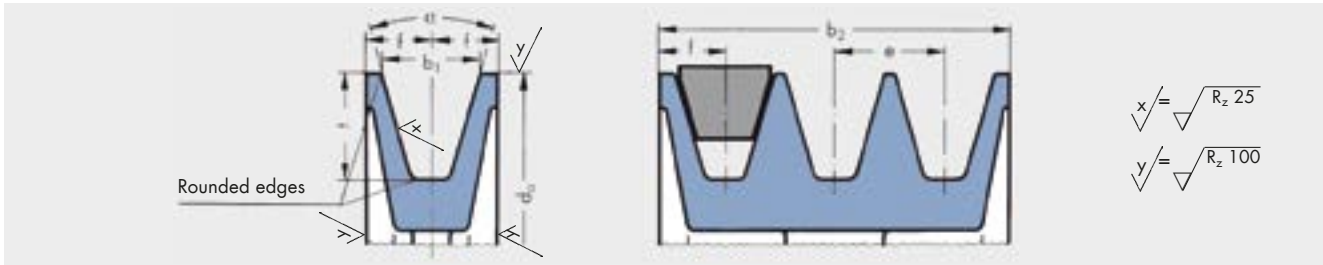

Table 16

Belt profile USA Standard RMA/MPTA	3V/9N	5V/15N	8V/25N	
b ₁	8.89 ± 0.13	15.24 ± 0.13	25.40 ± 0.13	
e	10.30 ± 0.40	17.50 ± 0.40	28.60 ± 0.40	
f	9.00 ^{+2.00} / _{-1.00}	13.00 ^{+3.00} / _{-1.00}	19.00 ^{+6.00} / _{-2.00}	
t _{min}	8.6	15.0	25.1	
d _{a min}	67	151	315	
α	36° ± 25' d _a 63 to 90	— —	— —	
	38° ± 25' d _a > 90 to 150	38° ± 25' d _a 140 to 255	38° ± 25' 315 to 405	
	40° ± 25' d _a > 150 to 305	40° ± 25' d _a > 255 to 405	40° ± 25' d _a > 405 to 570	
	42° ± 25' d _a > 305	42° ± 25' d _a > 405	42° ± 25' d _a > 570	
Face width b ₂ for number of grooves z: b ₂ = (z - 1) e + 2 f	1	18.0	26.0	38.0
	2	28.3	43.5	66.6
	3	38.6	61.0	95.2
	4	48.9	78.5	123.8
	5	59.2	96.0	152.4
	6	69.5	113.5	181.0
	7	79.8	131.0	209.6
	8	90.1	148.5	238.2
	9	100.4	166.0	266.8
	10	110.7	183.5	295.4
	11	121.0	201.0	324.0
	12	131.3	218.5	352.6

(values in mm)

For drives with several grooves the total of all deviations from the nominal value e for all groove distances of a pulley ± 0.8 mm must not be exceeded. For further details see USA standard RMA/MPTA.

Note

The allowed variations of V-grooved pulleys according to USA standard RMA/MPTA deviate only slightly from the values contained in ISO 5290 "Grooved pulleys for joint narrow V-belts (Kraftbands)". Therefore, optibelt KB kraftbands can be used in V-grooved pulleys manufactured according to both standards. These V-grooved pulleys are also suitable for optibelt SUPER X-POWER M=S V-belts.

STANDARD RANGE

optibelt **KS** V-GROOVED PULLEYS FOR KRAFTBANDS

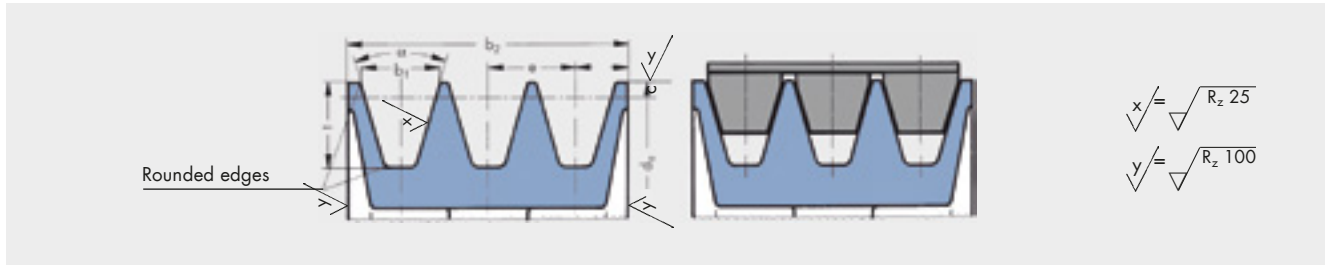

Table 17: V-grooved pulleys for kraftbands with wedge belts ISO 5290

Profile	d_a	α° $\pm 30'$	b_1 \approx	δh_{1max}	δh_{2max}	t_{min}	e	Tol $e^{1)}$	Σ Tol $e^{2)}$	f_{min}	$d_{a min}$
3V/9J	67 to 90 > 90 to 150 > 150 to 300 > 300	36 38 40 42	8.9	0.20	0.30	8.9	10.3	± 0.25	± 0.5	9	84 (3VX) 63
5V/15J	180 to 250 > 250 to 400 > 400	38 40 42	15.2	0.25	0.40	15.2	17.5	± 0.25	± 0.5	13	191 (5VX) 140
8V/25J	315 to 400 > 400 to 560 > 560	38 40 42	25.4	0.30	0.50	25.4	28.6	± 0.40	± 0.8	19	355

For further details please see standard ISO 5290.

1) Tolerance for the centre distance e of two adjacent grooves.

2) The sum of all deviations from the nominal dimension " e " for all groove distances of a pulley must not exceed the given tolerance.

The international standard ISO 5290 specifies pulley groove dimensions for belt profiles 3V/9J, 5V/15J, 8V/25J.

The groove top width " b_1 " is used as the basic reference dimension for standardisation of the grooves and joint V-belts. The pulley groove and joint V-belts are considered as a single unit in the standard ISO 5290.

The values δh_1 and δh_2 were chosen to ensure that

1. the top cover of the joint belt has no contact with the outside pulley diameter, in order to prevent the separation of the top cover.
2. the ribs are nevertheless still deep enough inside the pulley in order to ensure an optimum power transmission.

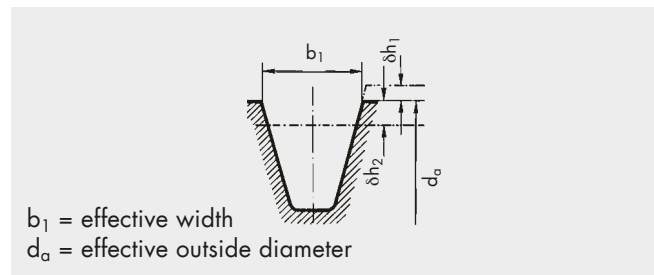

The groove faces must be straight at least to a level of $d_a - 2 \delta h_2$.

Table 18: V-grooved pulleys for kraftbands with wedge belts profiles SPZ, SPA, SPB and SPC according to DIN 2211/ ISO 4183

Profile	d_d	α° $\pm 30'$	b_1 \approx	c	t_{min}	e	Tol $e^{1)}$	Σ Tol $e^{2)}$	f_{min}	$d_{d min}$
SPZ	71 to 80 > 80	34 38	9.7	2.0	11	12.0	± 0.3	± 0.6	8.0	80
SPA	100 to 118 > 118	34 38	12.7	2.8	14	15.0	± 0.3	± 0.6	10.0	112 (XPA) 90
SPB	160 to 190 > 190	34 38	16.3	3.5	18	19.0	± 0.4	± 0.8	12.5	180 (XPB) 140
SPC	250 to 315 > 315	34 38	22.0	4.8	24	25.5	± 0.4	± 0.8	17.0	250

STANDARD RANGE

optibelt **KS** V-GROOVED PULLEYS FOR KRAFTBANDS

Table 19: V-grooved pulleys for kraftbands with classic V-belts ISO 5291/ASAE S211.5

Profile	d_a	$\alpha^\circ \pm 30'$	$b_1 \approx$	δh_{1max}	δh_{2max}	c	t_{min}	e	Tol e ¹⁾	Σ Tol e ²⁾	f_{min}	$d_{d min}$
AJ/HA	80 to 125 > 125	34 38	13.0	0.20	0.35	1.5	12.0	15.88	± 0.3	± 0.6	9.0	80
BJ/HB	130 to 195 > 195	34 38	16.5	0.25	0.40	2.0	14.0	19.05	± 0.4	± 0.8	11.5	130
CJ/HC	210 to 325 > 325	34 38	22.4	0.30	0.45	3.0	19.0	25.40	± 0.5	± 1.0	16.0	210
DJ/HD	370 to 490 > 490	36 38	32.8	0.30	0.55	4.5	26.0	36.53	± 0.6	± 1.2	23.0	370

1) Tolerance for the centre distance e of two adjacent grooves.

2) The sum of all deviations from the nominal dimension "e" for all groove distances of a pulley must not exceed the given tolerance.

Table 20: Pulley width ranges for kraftbands

Profile	3V/9J	5V/15J	8V/25J	SPZ	SPA	SPB	SPC	AJ/HA	BJ/HB	CJ/HC	DJ/HD
Number of grooves	Face width b_2 for number of grooves z $b_2 = (z - 1) e + 2 f$										
2	28.30	43.50	66.60	28.00	35.00	44.00	59.50	33.88	42.05	57.40	82.53
3	38.60	61.00	95.20	40.00	50.00	63.00	85.00	49.76	61.10	82.80	119.06
4	48.90	78.50	123.80	52.00	65.00	82.00	110.50	65.64	80.15	108.20	155.59
5	59.20	96.00	152.40	64.00	80.00	101.00	136.00	81.52	99.20	133.60	192.12
6	69.50	113.50	181.00	76.00	95.00	120.00	161.50	97.40	118.25	159.00	228.65
7	79.80	131.00	209.60	88.00	110.00	139.00	187.00	113.28	137.30	184.40	265.18
8	90.10	148.50	238.20	100.00	125.00	158.00	212.50	129.16	156.35	209.80	301.71
9	100.40	166.00	266.80	112.00	140.00	177.00	238.00	145.04	175.40	235.20	338.24
10	110.70	183.50	295.40	124.00	155.00	196.00	263.50	160.92	194.45	260.60	374.77
11	121.00	201.00	324.00	136.00	170.00	215.00	289.00	176.80	213.50	286.00	401.30
12	131.30	218.50	352.60	148.00	185.00	234.00	314.50	192.68	232.55	311.40	447.83
13	141.60	236.00	381.20	160.00	200.00	253.00	340.00	208.56	251.60	336.80	484.36
14	151.90	253.50	409.80	172.00	215.00	272.00	365.50	224.44	270.65	362.20	520.89
15	162.20	271.00	438.40	184.00	230.00	291.00	391.00	240.32	289.70	387.60	557.42
16	172.50	288.50	467.00	196.00	245.00	310.00	416.50	256.20	308.75	413.00	593.95
17	182.80	306.00	495.60	208.00	260.00	329.00	442.00	272.08	327.80	438.40	630.48
18	193.10	323.50	524.20	220.00	275.00	348.00	467.50	287.96	346.85	463.80	667.01
19	203.40	341.00	552.80	232.00	290.00	367.00	493.00	303.84	365.90	489.20	703.54
20	213.70	358.50	581.40	244.00	305.00	386.00	518.50	319.72	384.95	514.60	740.07
21	224.00	376.00	610.00	256.00	320.00	405.00	544.00	335.60	404.00	540.00	776.60
22	234.30	393.50	638.60	268.00	335.00	424.00	569.50	351.48	423.05	565.40	813.13
23	244.60	411.00	667.20	280.00	350.00	443.00	595.00	367.36	442.10	590.80	849.66
24	254.90	428.50	695.80	292.00	365.00	462.00	620.50	383.24	461.15	616.20	886.19
25	265.20	446.00	724.40	304.00	380.00	481.00	646.00	399.12	480.20	641.60	922.72
26	275.50	463.50	753.00	316.00	395.00	500.00	671.50	415.00	499.25	667.00	959.25
27	285.80	481.00	781.60	328.00	410.00	519.00	697.00	430.88	518.30	692.40	995.78
28	296.10	498.50	810.20	340.00	425.00	538.00	722.50	446.76	537.35	717.80	1032.31
29	306.40	516.00	838.80	352.00	440.00	557.00	748.00	462.64	556.40	743.20	1068.84
30	316.70	533.50	867.40	364.00	455.00	576.00	773.50	478.52	575.45	768.60	1105.37
31	327.00	551.00	896.00	376.00	470.00	595.00	799.00	494.40	594.50	794.00	1141.90
32	337.30	568.50	924.60	388.00	485.00	614.00	824.50	510.28	613.55	819.40	1178.43
33	347.60	586.00	953.20	400.00	500.00	633.00	850.00	526.16	632.60	844.80	1214.96
34	357.90	603.50	981.80	412.00	515.00	652.00	875.50	542.04	651.65	870.20	1251.49
35	368.20	621.00	1010.40	424.00	530.00	671.00	901.00	557.92	670.70	895.60	1288.02
36	378.50	638.50	1039.00	436.00	545.00	690.00	926.50	573.80	689.75	921.00	1324.55
37	388.80	656.00	1067.60	448.00	560.00	709.00	952.00	589.68	708.80	946.40	1361.08
38	399.10	673.50	1096.20	460.00	575.00	728.00	977.50	605.56	727.85	971.80	1397.61
39	409.40	691.00	1124.80	472.00	590.00	747.00	1003.00	621.44	746.90	997.20	1434.14
40	419.70	708.50	1153.40	484.00	605.00	766.00	1028.50	637.32	765.95	1022.60	1470.67

For KB sets please note the systematical classification.

STANDARD RANGE

OPTIBELT DEEP GROOVED PULLEYS

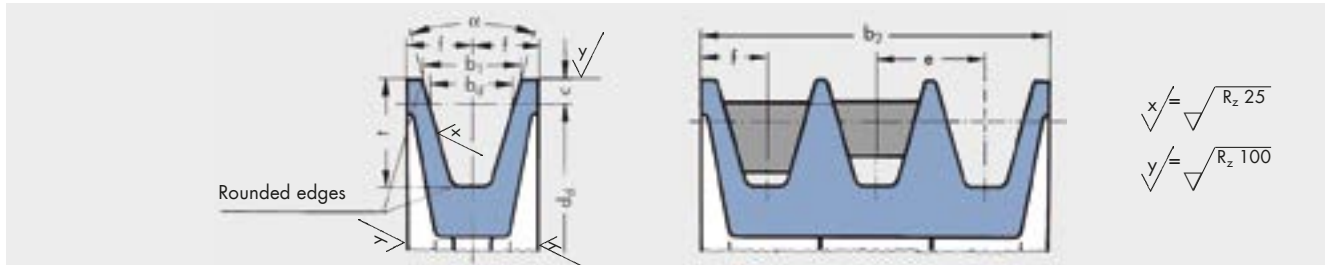

Table 21

Profile	DIN 7753 Part 1/ISO	SPZ	SPA	SPB	SPC	
Suitable for V-belts DIN 2215 and 2216		10	13	17	22	
b_d		8.5	11.0	14.0	19.0	
$b_1 \approx$		11.0	15.0	18.9	26.3	
$b_1 \approx$		11.3	15.4	19.5	27.3	
c		4.0	6.5	8.0	12.0	
e		14 ± 0.3	18 ± 0.3	23.0 ± 0.4	31 ± 0.5	
f		8 ± 0.6	10 ± 0.6	12.5 ± 0.8	17 ± 1.0	
t_{min}		13	18	22.5	31.5	
α		$34^\circ \pm 1^\circ$ d_d 63 to 80	$34^\circ \pm 1^\circ$ d_d 90 to 118	$34^\circ \pm 1^\circ$ d_d 140 to 190	$34^\circ \pm 30'$ d_d 224 to 315	
		$38^\circ \pm 1^\circ$ $d_d > 80$	$38^\circ \pm 1^\circ$ $d_d > 118$	$38^\circ \pm 1^\circ$ $d_d > 190$	$38^\circ \pm 30'$ $d_d > 315$	
α		$34^\circ \pm 1^\circ$ d_d 50 to 80	$34^\circ \pm 1^\circ$ d_d 71 to 118	$34^\circ \pm 1^\circ$ d_d 112 to 190	$34^\circ \pm 30'$ d_d 180 to 315	
		$38^\circ \pm 1^\circ$ $d_d > 80$	$38^\circ \pm 1^\circ$ $d_d > 118$	$38^\circ \pm 1^\circ$ $d_d > 190$	$38^\circ \pm 30'$ $d_d > 315$	
Face width b_2 for number of grooves z : $b_2 = (z - 1) e + 2 f$		1	16	20	25	34
		2	30	38	48	65
		3	44	56	71	96
		4	58	74	94	127
		5	72	92	117	158
		6	86	110	140	189
		7	100	128	163	220
		8	114	146	186	251
		9	128	164	209	282
		10	142	182	232	313
		11	160	200	255	344
		12	174	218	278	375

Please note the respective minimum pulley diameters.

Attention: Kraftbands are **not** suitable for deep grooved pulleys.

STANDARD RANGE

optibelt **KS** V-GROOVED PULLEYS FOR TAPER BUSHES – GROOVE ACCORDING TO DIN 2211

Profile SPZ/Z/10												
Datum diameter d_d [mm]	Number of grooves	Design		Weight without bushes [≈ kg]	Taper bush	Datum diameter d_d [mm]	Number of grooves	Design		Weight without bushes [≈ kg]	Taper bush	
50▲◆	1	●	11	0.3	1008	106	1	●	8	0.9	1610	
	2	●	11	0.4	1008		2	●	6	1.1	1610	
56▲◆	1	●	11	0.4	1008	106	3	●	6	1.3	1610	
	2	●	11	0.5	1108		4	●	6	1.3	1610	
60▲◆■	1	●	8	0.2	1008	106	5	●	6	1.5	2012	
	2	●	11	0.6	1108		6*	●	6	1.6	2012	
63	1	●	8	0.2	1108	112	1	●	8	1.0	1610	
	2	●	6	0.3	1108		2	●	6	1.3	1610	
	3	●	6	0.4	1108		3	●	6	1.3	2012	
67	1	●	8	0.3	1108	112	4	●	6	1.5	2012	
	2	●	6	0.4	1108		5	●	6	1.8	2012	
	3	●	6	0.5	1108		6*	●	6	1.9	2012	
71	1	●	8	0.3	1108	118	1	●	8	0.9	1610	
	2	●	6	0.4	1108		2	●	6	1.3	1610	
	3	●	6	0.6	1108		3	●	6	1.6	2012	
75	1	●	8	0.4	1108	118	4	●	6	1.8	2012	
	2	●	6	0.4	1210		5	●	6	1.8	2012	
	3	●	6	0.5	1210		6*	●	6	2.0	2517	
80	1	●	8	0.5	1210	125	1	●	8	1.0	1610	
	2	●	6	0.6	1210		2	●	6	1.4	1610	
	3	●	6	0.7	1210		3	●	2	1.8	2012	
	4	●	6	0.8	1210		4	●	2	2.2	2012	
85	1	●	8	0.6	1210	125	5	●	6	2.3	2012	
	2	●	6	0.5	1610		6*	●	6	2.5	2517	
	3	●	6	0.6	1610		132	1	●	8	1.1	1610
	4	●	6	0.9	1610			2	●	6	1.5	1610
	5	●	6	1.0	1610			3	●	2	2.3	2012
90	1	●	8	0.7	1210	132	4	●	2	2.5	2012	
	2	●	6	0.7	1610		5	●	6	2.7	2517	
	3	●	6	0.8	1610		6*	●	6	2.9	2517	
	4	●	6	1.0	1610		140	1	●	8	1.2	1610
	5	●	6	1.2	1610			2	●	2	1.7	1610
95	1	●	8	0.7	1210	140		3	●	2	2.6	2012
	2	●	6	0.8	1610		4	●	2	2.9	2012	
	3	●	6	0.9	1610		5	●	2	3.2	2517	
	4	●	6	1.1	1610		6*	●	2	3.5	2517	
	5	●	6	1.3	1610		8*	●	4	4.0	2517	
100	1	●	8	0.8	1210	150	1	●	8	1.2	1610	
	2	●	6	0.9	1610		2	●	8	2.0	2012	
	3	●	6	1.1	1610		3	●	2	3.1	2012	
	4	●	6	1.1	1610		4	●	2	3.7	2517	
	5	●	6	1.3	2012		5	●	2	4.0	2517	
	6*	●	6	1.4	2012		6*	●	2	4.4	2517	
						8*	●	4	5.1	2517		

▲ for profile 10 ◆ for profile ZX/X10 ■ for profile XPZ

Number of grooves z	1	2	3	4	5	6	8
Face width b_2 [mm]	16	28	40	52	64	76	100
Taper bush	1008	1108	1210	1610	2012	2517	
Bore d_2 [mm] from ... to ...	10-25	10-28	11-32	14-42	14-50	16-60	

- Solid pulley
 - Plate pulley (with or without holes)
 - × Spoked pulley
- Material: EN-GJL-200 (GG 20)
DIN EN 1561
- * Non stock items

Bore diameter d_2 see page 72

STANDARD RANGE

optibelt **KS** V-GROOVED PULLEYS FOR TAPER BUSHES – GROOVE ACCORDING TO DIN 2211

Profile SPZ/Z/10											
Datum diameter d_d [mm]	Number of grooves	Design		Weight without bushes [≈ kg]	Taper bush	Datum diameter d_d [mm]	Number of grooves	Design		Weight without bushes [≈ kg]	Taper bush
160	1	●	8	1.3	1610	280	1	x	7	2.9	2012
	2	●	8	2.5	2012		2	x	7	4.0	2012
	3	●	2	3.6	2012		3	x	7	5.3	2517
	4	●	2	4.4	2517		4	x	10	6.4	2517
	5	●	2	4.8	2517		5	x	10	7.1	2517
	6*	●	2	5.2	2517		6*	x	10	7.8	2517
	8*	●	4	5.6	2517		8*	x	10	10.8	3020
	170	1	●	8	1.5		1610	315	1	x	7
2		●	8	2.5	2012	2	x		7	4.2	2012
3		○	9	4.2	2012	3	x		7	6.1	2517
4		●	2	5.3	2517	4	x		10	7.6	2517
5		●	2	5.9	2517	5	x		10	8.6	2517
6*		●	2	6.5	2517	6*	x		10	9.3	2517
180	1	●	8	1.6	1610	355	1	x	7	3.5	2012
	2	●	8	2.5	2012		2	x	7	5.1	2012
	3	○	9	4.8	2012		3	x	7	7.3	2517
	4	○	9	6.1	2517		4	x	10	8.9	2517
	5	○	9	6.3	2517		5	x	10	10.0	2517
	6*	○	9	6.8	2517		6*	x	10	10.7	2517
	8*	●	4	7.1	3020		8*	x	10	16.0	3030
	190	1	●	8	1.8		1610	400	1	x	7
2		●	8	2.6	2012	2	x		7	6.3	2517
3		○	9	4.9	2012	3	x		7	8.0	2517
4		○	9	5.3	2517	4	x		10	10.1	2517
5		○	9	6.3	2517	5	x		10	11.7	3020
6*		○	9	6.9	2517	6*	x		10	14.5	3020
200	1	●	8	2.3	2012	450	1	x	7	6.1	2517
	2	●	8	2.8	2012		2	x	7	8.2	2517
	3	○	9	3.5	2012		3	x	7	9.8	2517
	4	○	9	4.7	2517		4	x	10	11.8	3020
	5	○	9	5.5	2517		5	x	10	13.9	3020
	6*	○	9	6.1	2517		6*	x	10	16.9	3030
	8*	●	4	9.3	3020		8*	x	10	24.0	3535
	224	1	○	5	2.5		2012	500	2	x	7
2		○	5	3.2	2012	3	x		7	11.4	2517
3		○	9	3.9	2012	4	x		10	14.3	3020
4		○	9	5.2	2517	5	x		10	17.6	3020
5		○	9	6.0	2517	6*	x		10	19.9	3020
6*		○	9	6.6	2517						
250	1	x	7	2.8	2012	630	3	x	7	15.9	2517
	2	x	7	3.5	2012		4	x	10	20.0	3020
	3	x	10	4.3	2012		5	x	10	22.7	3020
	4	x	10	5.7	2517		6*	x	7	33.6	3535
	5	x	10	7.0	2517						
	6	x	10	7.0	2517						
	8*	x	10	10.5	3020						

Number of grooves z	1	2	3	4	5	6	8
Face width b_2 [mm]	16	28	40	52	64	76	100
Taper bush	1610	2012	2517	3020	3030	3535	
Bore d_2 [mm] from ... to ...	14-42	14-50	16-60	25-75	35-75	35-90	

● Solid pulley
 ○ Plate pulley (with or without holes)
 × Spoked pulley
 Material: EN-GJL-200 (GG 20)
 DIN EN 1561
 * Non stock items

Bore diameter d_2 see page 72

STANDARD RANGE

optibelt **KS** V-GROOVED PULLEYS FOR TAPER BUSHES – GROOVE ACCORDING TO DIN 2211

Profile SPA/A/13												
Datum diameter d_d [mm]	Number of grooves	Design		Weight without bushes [≈ kg]	Taper bush	Datum diameter d_d [mm]	Number of grooves	Design		Weight without bushes [≈ kg]	Taper bush	
63♦	1	●	11	0.6	1108	118	1	●	8	1.2	1610	
	2	●	11	0.8	1108		2	●	6	1.4	1610	
67♦	1	●	8	0.3	1108	125	3	●	2	1.8	2012	
	2	●	6	0.5	1108		4	●	2	2.0	2012	
71▲♦■	1	●	8	0.3	1108		5	●	2	2.4	2012	
	2	●	6	0.5	1108		132	1	●	8	1.4	1610
	3	●	6	0.7	1108			2	●	2	1.7	1610
75▲♦■	1	●	8	0.4	1108	3		●	2	2.0	2012	
	2	●	6	0.6	1108	4	●	2	2.5	2012		
	3	●	6	0.8	1108	5	●	2	2.7	2012		
80▲♦■	1	●	8	0.5	1210	140	1	●	8	1.6	1610	
	2	●	6	0.6	1210		2	●	2	1.8	2012	
	3	●	6	0.9	1210		3	●	2	2.3	2012	
85▲♦■	1	●	8	0.6	1210		4	●	2	2.6	2517	
	2	●	6	0.7	1210		5	●	2	2.9	2517	
90	3	●	6	1.0	1210	150	1	●	8	1.8	1610	
	4	●	6	1.2	1615		2	●	2	2.0	2012	
	95	1	●	8	0.8		1210	3	●	2	2.8	2517
		2	●	6	0.9		1610	4	●	2	3.1	2517
100	3	●	6	1.1	1610		5	●	2	3.4	2517	
	4	●	6	1.4	1615	160	1	○	5	1.9	1610	
	106	1	●	8	0.9		1610	2	●	2	2.9	2012
		2	●	6	1.1		1610	3	●	2	3.9	2517
112	3	●	2	1.2	1610		4	●	2	4.4	2517	
	4	●	2	1.7	1610		5	●	2	5.1	2517	
	5	●	6	1.9	1610	170	1	○	5	2.0	1610	
106	1	●	8	0.9	1610		2	●	2	3.1	2012	
	2	●	6	1.1	1610		3	●	2	4.6	2517	
112	3	●	2	1.4	1610		4	●	2	5.5	2517	
	4	●	6	2.0	2012		5	●	2	5.9	3020	
	5	●	6	2.0	2012	180	1	○	5	2.1	1610	
106	1	●	8	0.9	1610		2	○	9	3.4	2012	
	2	●	6	1.1	1610		3	●	2	5.1	2517	
112	3	●	6	1.3	2012		4	●	2	5.9	2517	
	4	●	6	1.9	2012		5	●	2	6.2	3020	
	5	●	6	2.1	2012	190	1	○	5	2.3	1610	
106	1	●	8	0.9	1610		2	○	9	3.8	2012	
	2	●	6	1.1	1610		3	●	2	5.4	2517	
112	3	●	6	1.3	2012		4	●	2	6.8	2517	
	4	●	6	1.9	2012		5	●	2	7.4	3020	
	5	●	6	2.1	2012							

▲ for profile 13 ♦ for profile AX/X13 ■ for profile XPA

Number of grooves z	1	2	3	4	5		
Face width b_2 [mm]	20	35	50	65	80		
Taper bush	1108	1210	1610	1615	2012	2517	3020
Bore d_2 [mm] from ... to ...	10-28	11-32	14-42	14-42	14-50	16-60	25-75

● Solid pulley
○ Plate pulley (with or without holes)
× Spoked pulley
Material: EN-GJL-200 (GG 20)
DIN EN 1561

Bore diameter d_2 see page 72

STANDARD RANGE

optibelt **KS** V-GROOVED PULLEYS FOR TAPER BUSHES – GROOVE ACCORDING TO DIN 2211

Profile SPA/A/13											
Datum diameter d_d [mm]	Number of grooves	Design		Weight without bushes [≈ kg]	Taper bush	Datum diameter d_d [mm]	Number of grooves	Design		Weight without bushes [≈ kg]	Taper bush
200	1	○	5	2.6	2012	450	1	x	7	7.0	2012
	2	○	5	4.1	2517		2	x	7	10.3	2517
	3	○	9	4.9	2517		3	x	7	14.1	3020
	4	●	2	7.4	3020		4	x	10	15.5	3020
	5	●	4	8.4	3020		5	x	7	24.3	3535
212	1	○	5	2.7	2012	500	1	x	7	8.0	2517
	2	○	5	4.3	2517		2	x	7	11.6	2517
	3	○	9	5.2	2517		3	x	7	16.0	3020
	4	●	2	7.3	3020		4	x	10	18.2	3020
	5	●	2	8.2	3020		5	x	7	27.3	3535
224	1	x	7	2.7	2012	560	1	x	7	11.6	2517
	2	○	5	4.4	2517		2	x	7	15.5	3020
	3	○	9	5.5	2517		3	x	7	17.8	3020
	4	●	2	7.4	3020		4	x	7	26.7	3535
	5	●	2	8.3	3020		5	x	7	30.4	3535
236	1	x	7	2.8	2012	630	1	x	7	10.1	2517
	2	○	5	4.6	2517		2	x	7	16.0	3020
	3	○	9	5.7	2517		3	x	7	22.0	3020
	4	●	2	7.8	3020		4	x	7	30.8	3535
	5	●	2	8.7	3020		5	x	7	33.7	3535
250	1	x	7	2.9	2012						
	2	x	7	4.8	2517						
	3	○	9	5.9	2517						
	4	○	9	8.0	3020						
	5	○	9	9.0	3020						
280	1	x	7	3.3	2012						
	2	x	7	5.4	2517						
	3	○	9	6.7	2517						
	4	○	9	8.8	3020						
	5	○	5	15.5	3535						
315	1	x	7	3.6	2012						
	2	x	7	6.0	2517						
	3	○	5	8.3	3020						
	4	○	9	9.7	3020						
	5	○	5	17.0	3535						
355	1	x	7	4.2	2012						
	2	x	7	6.7	2517						
	3	x	7	9.2	3020						
	4	x	10	11.0	3020						
	5	x	7	18.6	3535						
400	1	x	7	4.9	2012						
	2	x	7	8.1	2517						
	3	x	7	11.0	3020						
	4	x	10	12.8	3020						
	5	x	7	21.0	3535						

Number of grooves z	1	2	3	4	5
Face width b_2 [mm]	20	35	50	65	80
Taper bush	2012	2517	3020	3535	
Bore d_2 [mm] from ... to ...	14-50	16-60	25-75	35-90	

● Solid pulley
 ○ Plate pulley (with or without holes)
 × Spoked pulley
 Material: EN-GJL-200 (GG 20)
 DIN EN 1561

Bore diameter d_2 see page 72

STANDARD RANGE

optibelt **KS** V-GROOVED PULLEYS FOR TAPER BUSHES – GROOVE ACCORDING TO DIN 2211

Profile SPB/B/17												
Datum diameter d_d [mm]	Number of grooves	Design		Weight without bushes [≈ kg]	Taper bush	Datum diameter d_d [mm]	Number of grooves	Design		Weight without bushes [≈ kg]	Taper bush	
100♦	1	●	1	0.9	1610	180	1	●	1	4.1	1610	
	2	●	6	1.2	1610		2	●	8	4.5	2517	
	3	●	6	1.7	1610		3	●	2	5.5	2517	
112▲♦■	1	●	1	1.1	1610		4	●	4	6.9	2517	
	2	●	6	1.5	1610		5	●	4	7.1	3020	
	3	●	6	2.0	1610		6	●	4	7.7	3020	
118▲♦■	1	●	1	1.3	1610	190	8	●	4	9.5	3020	
	2	●	6	1.7	1610		1	●	8	4.6	2012	
	3	●	6	2.3	1610		2	●	8	5.0	2517	
125▲♦■	1	●	1	1.5	1610		3	●	2	6.3	2517	
	2	●	2	1.9	2012		4	●	4	7.6	2517	
	3	●	2	2.4	2012		5	●	4	8.1	3020	
	4	●	4	3.0	2012		6	●	4	9.2	3020	
	5	●	6	3.5	2012		8	●	4	11.2	3030	
132▲	1	●	1	1.8	1610	200	1	●	8	5.0	2012	
	2	●	2	2.2	2012		2	●	8	5.4	2517	
	3	●	2	2.8	2012		3	●	2	6.5	2517	
	4	●	4	3.4	2012		4	●	2	8.8	3020	
	5	●	4	3.7	2012		5	●	2	9.1	3020	
140	1	●	1	2.3	1610		6	●	4	10.3	3020	
	2	●	2	2.7	2012		8	●	4	13.5	3535	
	3	●	2	3.3	2012		212	1	●	8	4.2	2012
	4	●	2	3.7	2517			2	●	8	4.9	2517
	5	●	2	4.5	2517			3	●	2	6.0	2517
	6	●	4	4.6	2517			4	●	2	9.8	3020
150	1	●	1	2.7	1610			5	●	2	11.0	3020
	2	●	2	3.1	2012			6	●	4	14.3	3535
	3	●	2	3.9	2517		8	●	4	16.6	3535	
	4	●	2	4.4	2517		224	1	●	8	4.7	2012
	5	●	4	5.2	2517			2	●	8	5.3	2517
	6	●	4	5.6	2517			3	●	2	6.3	2517
160	1	●	1	2.5	1610			4	●	2	11.3	3020
	2	●	2	2.9	2012			5	●	2	12.7	3020
	3	●	2	4.2	2517			6	●	4	17.0	3535
	4	●	4	4.9	2517		8	●	4	19.3	3535	
	5	●	4	6.0	2517		10	●	4	21.8	3535	
	6	●	4	5.4	3020		236	1	●	8	5.0	2012
170	1	●	1	2.9	1610			2	●	8	5.5	2517
	2	●	2	3.3	2012			3	x	10	7.0	2517
	3	●	2	4.9	2517			4	x	10	14.5	3020
	4	●	4	5.7	2517			5	●	6	16.9	3535
	5	●	4	6.1	3020			6	●	4	20.0	3535
	6	●	4	6.5	3020		8	●	4	22.3	3535	
	8	●	4	8.0	3020		10	●	4	25.3	3535	

▲ for profile 17 ♦ for profile BX/X17 ■ for profile XPB

Number of grooves z	1	2	3	4	5	6	8	10
Face width b_2 [mm]	25	44	63	82	101	120	158	196
Taper bush	1610	2012	2517	3020	3030	3535		
Bore d_2 [mm] from ... to ...	14-42	14-50	16-60	25-75	35-75	35-90		

● Solid pulley
 ○ Plate pulley (with or without holes)
 × Spoked pulley
 Material: EN-GJL-200 (GG 20)
 DIN EN 1561

Bore diameter d_2 see page 72

STANDARD RANGE

optibelt **KS** V-GROOVED PULLEYS FOR TAPER BUSHES – GROOVE ACCORDING TO DIN 2211

Profile SPB/B/17											
Datum diameter d_d [mm]	Number of grooves	Design		Weight without bushes [≈ kg]	Taper bush	Datum diameter d_d [mm]	Number of grooves	Design		Weight without bushes [≈ kg]	Taper bush
250	1	●	8	5.4	2012	355	2	x	7	8.7	3020
	2	x	7	5.5	2517		3	x	10	10.8	3020
	3	●	2	7.7	3020		4	x	7	18.6	3535
	4	●	2	19.6	3020		5	x	10	20.8	3535
	5	●	2	21.7	3535		6	○	9	22.8	3535
	6	●	4	23.3	3535		8	x	10	27.0	3535
	8	●	4	27.5	3535		10*	x	10	38.0	4040
265	10	●	4	29.3	3535	375	2	x	7	9.5	3020
	2	●	7	6.2	2517		3	x	10	11.5	3020
	3	○	9	8.0	3020		4	x	10	16.5	3525
	4	○	9	9.5	3020		6	x	10	25.0	3535
	6	○	9	16.7	3525		8	x	10	28.0	4040
280	8	○	9	24.0	3525	400	2	x	7	10.0	3020
	1	x	7	6.1	2012		3	x	7	18.3	3535
	2	x	7	6.8	2517		4	x	7	20.5	3535
	3	x	10	8.6	3020		5	x	10	23.4	3535
	4	○	9	10.1	3020		6	x	10	25.1	3535
	5	○	9	17.8	3535	8	x	10	36.5	4040	
	6	○	9	19.6	3535	10*	x	10	41.0	4040	
	8	○	9	26.7	3535	425	2	x	7	11.5	3020
	10	○	9	30.5	3535		3	x	7	18.0	3535
	300	2	x	7	7.3		2517	4	x	10	19.5
3		x	10	9.2	3020		6	x	10	25.1	4040
4		○	9	14.3	3020		8	x	10	52.5	4545
5		○	9	18.2	3535	450	2	x	7	12.1	3020
6		○	9	21.9	3535		3	x	7	21.9	3535
8	○	9	26.2	3535	4		x	7	24.5	3535	
315	1	x	7	7.2	2012		5	x	10	27.3	3535
	2	x	7	7.8	2517		6	x	10	35.5	4040
	3	x	10	9.6	3020	8	x	10	40.9	4040	
	4	○	5	17.1	3535	10*	x	10	53.5	4545	
	5	○	9	18.8	3535	500	2	x	7	13.2	3020
	6	○	9	23.0	3535		3	x	7	23.1	3535
	8	○	9	26.0	3535		4	x	7	26.6	3535
	10	○	9	31.5	3535		5	x	10	29.9	3535
335	2	x	7	7.8	2517		6	x	10	38.9	4040
	3	x	10	10.5	3020	8	x	10	45.5	4040	
	4	x	7	18.3	3535	10*	x	10	61.0	4545	
	5	x	10	19.5	3535	560	2	x	7	16.5	3030
	6	x	10	22.0	3535		3	x	7	25.9	3535
	8	x	10	28.2	3535		4	x	7	29.0	3535
	10*	x	10	36.0	4040		5	x	7	35.3	4040
					6		x	10	43.1	4040	
					8	x	10	49.0	4545		
					10*	x	10	55.7	4545		

Number of grooves z	1	2	3	4	5	6	8	10
Face width b_2 [mm]	25	44	63	82	101	120	158	196
Taper bush	2012	2517	3020	3030	3535	4040	4545	
Bore d_2 [mm] from ... to ...	14-50	16-60	25-75	35-75	35-90	40-100	55-110	

● Solid pulley
 ○ Plate pulley (with or without holes)
 × Spoked pulley
 Material: EN-GJL-200 (GG 20)
 DIN EN 1561
 * Non stock items

Bore diameter d_2 see page 72

STANDARD RANGE

optibelt **KS** V-GROOVED PULLEYS FOR TAPER BUSHES – GROOVE ACCORDING TO DIN 2211

Profile SPB/B/17											
Datum diameter d_d [mm]	Number of grooves	Design		Weight without bushes [≈ kg]	Taper bush	Datum diameter d_d [mm]	Number of grooves	Design		Weight without bushes [≈ kg]	Taper bush
630	2	x	7	18.5	3020						
	3	x	7	28.9	3535						
	4	x	7	33.3	3535						
	5	x	7	43.1	4040						
	6	x	10	49.2	4040						
	8	x	10	62.0	4545						
	10*	x	10	72.0	4545						
710	3	x	7	33.2	3535						
	4	x	7	39.1	3535						
	5	x	7	50.2	4040						
	6	x	10	62.3	4545						
	8	x	10	71.0	4545						
	10*	x	10	80.0	4545						
800	3	x	7	36.7	3535						
	4	x	7	48.8	4040						
	5	x	7	56.1	4040						
	6	x	10	71.4	4545						
	8	x	10	90.9	4545						
	10*	x	10	102.0	4545						
900	3	x	7	46.8	3535						
	4	x	7	60.0	4040						
	5	x	7	74.8	4545						
	6	x	10	81.5	4545						
	8	x	10	110.0	4545						
	10*	x	10	126.0	5050						
1000	3	x	7	56.5	4040						
	4	x	7	66.5	4040						
	5	x	7	80.5	4545						
	6	x	10	90.0	4545						
	8	x	10	132.0	5050						
	10*	x	10	147.0	5050						

Number of grooves z	2	3	4	5	6	8	10
Face width b_2 [mm]	44	63	82	101	120	158	196
Taper bush	3020	3030	3535	4040	4545	5050	
Bore d_2 [mm] from ... to ...	25-75	35-75	35-90	40-100	55-110	70-125	

● Solid pulley
 ○ Plate pulley (with or without holes)
 × Spoked pulley
 Material: EN-GJL-200 (GG 20)
 DIN EN 1561
 * Non stock items
 Bore diameter d_2 see page 72

STANDARD RANGE

optibelt **KS** V-GROOVED PULLEYS FOR TAPER BUSHES – GROOVE ACCORDING TO DIN 2211

Profile SPC/C/22											
Datum diameter d_d [mm]	Number of grooves	Design		Weight without bushes [≈ kg]	Taper bush	Datum diameter d_d [mm]	Number of grooves	Design		Weight without bushes [≈ kg]	Taper bush
200▲◆■	3	●	4	9.0	2517	315	3	○	5	21.6	3535
	4	●	4	10.5	3020		4	○	9	24.6	3535
	5	●	4	14.0	3535		5	○	9	29.0	3535
	6	●	4	17.0	3535		6	○	9	31.4	3535
212▲◆■	3	●	4	10.0	3020	335	8	●	4	50.0	4040
	4	●	4	12.5	3020		10*	○	9	58.0	4545
	5	●	4	15.0	3535		3	○	5	22.5	3535
	6	●	4	18.0	3535		4	○	9	26.5	3535
224	2	●	4	8.1	3020	355	5	○	9	30.0	3535
	3	●	4	11.0	3020		6	○	9	35.0	3535
	4	●	4	14.0	3535		8	○	9	58.0	4040
	5	●	4	16.2	3535		3	○	5	22.9	3535
	6	●	4	19.0	3535		4	○	9	28.3	3535
236	8	●	4	24.9	3535	375	5	○	9	32.5	3535
	3	●	4	12.0	3020		6	○	9	36.0	3535
	4	●	4	17.2	3535		8	○	9	67.5	4040
	5	●	4	19.1	3535		10*	○	9	121.0	4545
250	6	●	4	20.8	3535	400	3	○	5	23.8	3535
	8	●	4	24.9	3535		4	○	9	30.0	3535
	10*	●	4	34.0	4040		5	○	9	33.0	3535
	2	●	4	9.8	3020		6	○	9	45.5	4040
	3	●	4	14.5	3020		8	○	9	68.0	4545
	4	●	4	20.7	3535		3	x	7	24.1	3535
	5	●	4	22.8	3535		4	x	10	28.0	3535
	6	●	4	26.0	3535		5	x	10	34.0	3535
265	8	●	4	29.7	3535	425	6	○	9	48.0	4040
	10*	●	4	34.0	4040		8	○	9	65.0	4545
	3	●	8	21.2	3535		10*	○	9	88.0	5050
	4	○	9	24.0	3535		3	x	7	26.0	3535
	5	○	9	26.2	3535		4	x	10	31.0	3535
280	6	○	9	29.0	3535	450	5	○	9	45.0	4040
	8	○	9	33.3	3535		6	○	9	58.0	4545
	3	●	8	24.0	3535		8	○	9	74.0	4545
	4	○	9	29.0	3535		3	x	7	28.6	3535
	5	○	9	31.0	3535		4	x	10	33.5	3535
300	6	○	9	33.8	3535	475	5	x	10	45.0	4040
	8	○	9	37.5	3535		6	○	9	61.1	4545
	10*	○	9	45.0	4040		8	○	9	78.7	5050
	3	○	5	21.0	3535		10*	○	9	101.0	5050
	4	○	9	25.0	3535		3	x	7	40.0	3535
	5	○	9	28.5	3535		4	x	10	47.0	3535
3535	6	○	9	29.0	3535	5050	5	x	10	47.2	4040
	8	●	4	46.5	4040		6	○	9	62.8	4545
	10*	○	9	53.5	4545		8	○	9	81.5	5050
	3	○	5	21.0	3535						
	4	○	9	25.0	3535						

▲ for profile 22 ◆ for profile CX/X22 ■ for profile XPC

Number of grooves z	3	4	5	6	8	10
Face width b_2 [mm]	85	110.5	136	161.5	212.5	263.5
Taper bush	2517	3020	3535	4040	4545	5050
Bore d_2 [mm] from ... to ...	16-60	25-75	35-90	40-100	55-110	70-125

- Solid pulley
 - Plate pulley (with or without holes)
 - × Spoked pulley
- Material: EN-GJL-200 (GG 20)
DIN EN 1561
* Non stock items

Bore diameter d_2 see page 72

STANDARD RANGE

optibelt **KS** V-GROOVED PULLEYS FOR TAPER BUSHES – GROOVE ACCORDING TO DIN 2211

Profile SPC/C/22											
Datum diameter d_d [mm]	Number of grooves	Design		Weight without bushes [≈ kg]	Taper bush	Datum diameter d_d [mm]	Number of grooves	Design		Weight without bushes [≈ kg]	Taper bush
500	3	x	7	30.9	3535						
	4	x	10	39.0	3535						
	5	x	10	48.7	4040						
	6	x	10	60.2	4545						
	8	○	9	87.4	5050						
10*	○	9	127.0	5050							
560	3	x	7	36.0	3535						
	4	x	10	50.0	4040						
	5	x	10	63.0	4545						
	6	x	10	77.0	5050						
	8	x	10	94.0	5050						
10*	○	9	115.0	5050							
630	3	x	7	48.5	4040						
	4	x	7	61.0	4545						
	5	x	10	77.0	5050						
	6	x	10	86.0	5050						
	8	x	10	105.5	5050						
10*	○	9	130.0	5050							
710	3	x	7	—	4040						
	4	x	7	—	4545						
	5	x	10	—	5050						
	6	x	10	—	5050						
	8	x	10	—	5050						
10*	○	9	—	5050							
800	3	x	7	—	4545						
	4	x	7	—	5050						
	5	x	10	—	5050						
	6	x	10	—	5050						
	8	x	10	—	5050						
10*	○	9	—	5050							
1000	5	x	10	—	5050						
	6	x	10	—	5050						
	8	x	10	—	5050						
	10*	○	9	—	5050						
1250	5	x	10	—	5050						
	6	x	10	—	5050						
	8	x	10	—	5050						
	10*	○	9	—	5050						

Number of grooves z	3	4	5	6	8	10
Face width b_2 [mm]	85	110,5	136	161,5	212,5	263,5
Taper bush	3535	4040	4545	5050		
Bore d_2 [mm] from ... to ...	35-90	40-100	55-110	70-125		

- Solid pulley
 - Plate pulley (with or without holes)
 - × Spoked pulley
- Material: EN-GJL-200 (GG 20)
DIN EN 1561
- * Non stock items

Bore diameter d_2 see page 72

STANDARD RANGE

optibelt **KS** V-GROOVED PULLEYS FOR CYLINDRICAL BORES – GROOVE ACCORDING TO DIN 2211

Profile SPZ/Z/10											
Datum diameter d _d [mm]	Number of grooves	Design	Weight [≈ kg]	Finished bore d _{max} [mm]	Hub length l [mm]	Datum diameter d _d [mm]	Number of grooves	Design	Weight [≈ kg]	Finished bore d _{max} [mm]	Hub length l [mm]
45▲◆	1	○	0.23	16	24	132	1	○	0.81	30	24
	2	○	0.30	16	35		2	○	1.30	38	35
	3	○	0.40	16	35		3	○	1.62	40	40
50▲◆	1	○	0.30	20	24	140	1	○	0.92	28	24
	2	○	0.40	20	35		2	○	1.40	38	38
	3	○	0.50	20	40		3	○	1.69	38	40
56▲◆■	1	○	0.32	20	24	150	1	x	1.05	28	24
	2	○	0.45	25	35		2	○	1.50	38	38
	3	○	0.65	25	40		3	○	1.85	38	40
63	1	○	0.34	25	24	160	1	x	1.22	32	30
	2	○	0.60	25	35		2	x	1.60	38	38
	3	○	0.85	25	40		3	x	2.40	42	40
71	1	○	0.34	25	24	170	1	x	1.66	40	30
	2	○	0.62	25	35		2	x	1.85	40	38
	3	○	1.00	30	40		3	x	3.00	42	40
75	1	○	0.35	24	24	180	1	x	2.10	32	30
	2	○	0.64	24	35		2	x	3.05	38	38
	3	○	1.05	28	40		3	x	3.50	42	40
80	1	○	0.35	25	24	190	1	x	2.25	35	30
	2	○	0.65	30	35		2	x	2.35	35	38
	3	○	1.10	38	35		3	x	4.00	35	40
85	1	○	0.30	25	24	200	1	x	2.40	32	38
	2	○	0.70	30	35		2	x	2.85	38	38
	3	○	1.10	38	35		3	x	4.45	42	40
90	1	○	0.38	25	24	212	1	x	2.60	35	30
	2	○	0.75	30	35		2	x	3.40	35	38
	3	○	1.15	38	38		3	x	5.00	38	40
95	1	○	0.40	28	24	225	1	x	2.80	32	38
	2	○	0.83	28	35		2	x	4.00	38	38
	3	○	1.20	38	38		3	x	5.30	42	40
100	1	○	0.48	28	24	250	1	x	3.30	32	38
	2	○	0.90	30	35		2	x	4.80	38	38
	3	○	1.25	38	38		3	x	6.00	42	40
106	1	○	0.50	30	24	280	1	x	3.85	35	34
	2	○	0.96	28	35		2	x	5.20	42	38
	3	○	1.32	38	38		3	x	7.00	48	40
112	1	○	0.54	28	24	315	1	x	4.35	35	34
	2	○	1.00	30	35		2	x	6.80	42	38
	3	○	1.40	38	38		3	x	8.25	48	40
118	1	○	0.60	28	24	355	1	x	4.60	35	34
	2	○	1.10	38	35		2	x	8.00	42	40
	3	○	1.47	38	38		3	x	10.00	48	45
125	1	○	0.70	28	24						
	2	○	1.20	30	35						
	3	○	1.55	38	40						

▲ for profile Z/10 ◆ for profile ZX/X10 ■ for profile XPZ

Number of grooves z	1	2	3
Face width b ₂ [mm]	16	28	40

● Solid pulley
 ○ Plate pulley (with or without holes)
 x Spoked pulley
 Hub position: flush one-sided
 Material: EN-GJL-200 (GG 20) – DIN EN 1561

STANDARD RANGE

optibelt **KS** V-GROOVED PULLEYS FOR CYLINDRICAL BORES – GROOVE ACCORDING TO DIN 2211

Profile SPA/A/13												
Datum diameter d_d [mm]	Number of grooves	Design	Weight [≈ kg]	Finished bore d_{max} [mm]	Hub length l [mm]	Datum diameter d_d [mm]	Number of grooves	Design	Weight [≈ kg]	Finished bore d_{max} [mm]	Hub length l [mm]	
50	1	○	0.34	18	34	106	1	○	0.88	28	34	
	2	○	0.48	18	49		2	○	1.65	28	49	
	3	○	0.55	18	47		3	○	2.20	32	42	
56	1	○	0.42	20	34		4▽	○	3.24	32	53	
	2	○	0.62	20	49		5▽	○	3.85	35	60	
	3	○	0.74	20	47		112	1	○	1.09	28	34
63♦	2	○	0.77	25	49			2	○	1.75	38	49
	3	○	0.85	25	47			3	○	2.38	38	42
	4▽	○	1.23	25	60			4▽	○	3.37	42	53
	5▽	○	1.48	25	70			5▽	○	3.95	42	60
	71▲◆■	1	○	0.50	25		34	118	1	○	1.10	32
2		○	0.89	28	49		2		○	1.80	38	49
3		○	0.96	32	42		3		○	2.42	42	42
4▽		○	1.47	32	60		4▽		○	3.42	42	53
5▽		○	1.83	32	70		5▽		○	4.10	48	65
75▲◆■	1	○	0.53	24	34	125	1	○	1.38	32	34	
	2	○	1.02	24	49		2	○	1.90	38	49	
	3	○	1.08	24	42		3	○	2.55	42	42	
	4▽	○	1.76	24	60		4▽	○	3.49	42	53	
	5▽	○	1.92	28	82		5▽	○	4.40	48	65	
80▲◆■	1	○	0.56	28	34	132	1	○	1.45	32	34	
	2	○	1.04	32	49		2	○	2.20	38	49	
	3	○	1.19	38	42		3	○	2.58	42	42	
	4▽	○	1.89	38	60		4▽	○	3.58	42	53	
	5▽	○	2.00	38	55		5▽	○	4.75	48	65	
85▲◆■	1	○	0.64	24	34	140	1	○	1.52	32	34	
	2	○	1.20	28	49		2	○	2.33	38	49	
	3	○	1.40	28	42		3	○	2.63	42	42	
	4▽	○	1.98	28	53		4▽	○	3.65	42	53	
	5▽	○	2.20	32	55		5▽	○	4.95	48	65	
90	1	○	0.88	28	34	150	1	x	1.60	38	36	
	2	○	1.47	32	49		2	x	2.59	38	49	
	3	○	1.62	38	42		3	○	2.95	42	42	
	4▽	○	2.22	42	53		4▽	○	4.04	42	53	
	5▽	○	2.51	42	67		5▽	○	5.15	48	65	
95	1	○	0.76	28	34	160	1	x	1.75	38	36	
	2	○	1.57	28	49		2	x	2.40	38	49	
	3	○	1.89	28	42		3	x	2.80	42	42	
	4▽	○	2.47	32	53		4▽	○	3.62	48	60	
	5▽	○	2.75	35	67		5▽	○	5.45	48	70	
100	1	○	0.84	28	34	170	1	x	2.00	35	36	
	2	○	1.36	32	49		2	x	2.90	35	49	
	3	○	1.98	38	52		3	x	3.20	35	42	
	4▽	○	2.72	42	53		4▽	x	4.20	35	60	
	5▽	○	3.10	42	60		5▽	x	5.80	38	70	

▲ for profile A/13 ♦ for profile AX/X13 ■ for profile XPA

▽ $d_d + 4$ mm

Number of grooves z	1	2	3	4	5
Face width b_2 [mm]	20	35	50	67	82

● Solid pulley
 ○ Plate pulley (with or without holes)
 x Spoked pulley
 Hub position: flush one-sided
 Material: EN-GJL-200 (GG 20) – DIN EN 1561

STANDARD RANGE

optibelt **KS** V-GROOVED PULLEYS FOR CYLINDRICAL BORES – GROOVE ACCORDING TO DIN 2211

Profile SPA/A/13											
Datum diameter d_d [mm]	Number of grooves	Design	Weight [≈ kg]	Finished bore d_{max} [mm]	Hub length l [mm]	Datum diameter d_d [mm]	Number of grooves	Design	Weight [≈ kg]	Finished bore d_{max} [mm]	Hub length l [mm]
180	1	x	2.02	38	36	315	1	x	4.78	48	44
	2	x	3.15	42	49		2	x	6.60	48	53
	3	x	3.60	42	42		3	x	8.75	55	47
	4▽	x	4.65	48	60		4▽	x	11.80	55	60
	5▽	x	6.13	48	70		5▽	x	12.50	60	70
190	1	x	2.02	38	36	355	1	x	5.50	48	44
	2	x	3.20	42	49		2	x	7.70	55	53
	3	x	4.00	42	42		3	x	9.55	55	47
	4▽	x	5.24	48	60		4▽	x	11.80	55	60
	5▽	x	6.31	48	70		5▽	x	12.85	60	70
200	1	x	2.40	38	36	400	1▽	x	6.85	50	50
	2	x	2.85	42	49		2▽	x	8.80	55	53
	3	x	4.21	48	42		3▽	x	10.95	60	47
	4▽	x	4.95	55	60		4▽	x	12.40	60	67
	5▽	x	6.45	60	70		5▽	x	15.90	60	82
212	1	x	2.70	40	36	450	1▽	x	7.50	55	50
	2	x	3.40	42	49		2▽	x	9.40	55	53
	3	x	4.40	42	42		3▽	x	12.15	60	47
	4▽	x	5.68	42	60		4▽	x	14.20	65	67
	5▽	x	6.85	42	70		5▽	x	18.30	65	82
225	1	x	2.75	40	36	500	1▽	x	10.50	55	50
	2	x	3.87	42	49		2▽	x	10.70	55	55
	3	x	4.60	42	42		3▽	x	13.45	60	60
	4▽	x	6.50	42	60		4▽	x	16.25	65	67
	5▽	x	7.25	42	70		5▽	x	22.80	65	82
236	1	x	3.30	38	36	560	1▽	x	14.00	55	60
	2	x	4.10	42	49		2▽	x	13.10	55	60
	3	x	4.90	48	42		3▽	x	15.60	60	74
	4▽	x	6.20	55	60		4▽	x	19.40	65	67
	5▽	x	7.50	55	70		5▽	x	24.50	65	82
250	1	x	3.40	42	36						
	2	x	4.32	48	49						
	3	x	5.30	48	42						
	4▽	x	7.00	55	60						
	5▽	x	7.85	60	70						
280	1	x	3.90	42	44						
	2	x	5.35	48	53						
	3	x	6.50	48	47						
	4▽	x	8.52	55	60						
	5▽	x	9.90	60	70						
300	1	x	4.25	48	44						
	2	x	5.90	48	53						
	3	x	7.50	55	47						
	4▽	x	9.82	55	60						
	5▽	x	11.30	60	70						
▽ $d_d + 4$ mm						▽ $d_d + 4$ mm					

Number of grooves z	1	2	3	4	5
Face width b_2 [mm]	20	35	50	67	82

● Solid pulley
 ○ Plate pulley (with or without holes)
 x Spoked pulley
 Hub position: flush one-sided
 Material: EN-GJL-200 (GG 20) – DIN EN 1561

STANDARD RANGE

optibelt **KS** V-GROOVED PULLEYS FOR CYLINDRICAL BORES – GROOVE ACCORDING TO DIN 2211

Profile SPB/B/17																	
Datum diameter d_d [mm]	Number of grooves	Design	Weight [≈ kg]	Finished bore d_{max} [mm]	Hub length [mm]	Datum diameter d_d [mm]	Number of grooves	Design	Weight [≈ kg]	Finished bore d_{max} [mm]	Hub length [mm]						
56	1	○	0.61	20	41	112▲◆■	1	○	1.53	32	41						
	2	○	1.00	20	60		2	○	2.35	38	60						
	3	○	1.00	22	62		3	○	3.10	38	55						
63	1	○	0.76	20	41		4▽	○	4.75	42	67						
	2	○	1.20	20	60		5▽	○	5.61	42	75						
	3	○	1.20	22	62		6▽	○	6.15	42	85						
71	1	○	0.79	22	41	118▲◆■	1	○	1.57	32	41						
	2	○	1.31	22	60		2	○	2.43	38	60						
	3	○	1.60	22	55		3	○	3.20	42	55						
75	1	○	0.82	25	41		4▽	○	6.20	42	70						
	2	○	1.42	25	60		5▽	○	7.20	42	75						
	3	○	1.85	25	62		6▽	○	6.60	42	85						
80	1	○	1.03	28	41	125▲◆■	1	○	1.66	32	41						
	2	○	1.65	28	60		2	○	2.55	38	60						
	3	○	2.05	28	70		3	○	3.28	42	55						
	85	1	○	1.10	30		41	4▽	○	4.74	42	70					
		2	○	1.70	30		60	5▽	○	8.60	42	75					
3		○	2.15	30	55		6▽	○	8.00	48	85						
4▽	○	2.70	30	70	132▲◆■	1	○	1.88	30	41							
5▽	○	3.00	30	75		2	○	2.63	30	60							
90◆	1	○	1.17	32		41	3	○	3.49	42	55						
	2	○	1.80	38		60	4▽	○	6.30	42	70						
	3	○	2.30	38		55	5▽	○	9.40	42	75						
	4▽	○	3.05	38		70	6▽	○	8.50	42	85						
	5▽	○	3.30	38	75	140	1	○	2.10	32	41						
95◆	1	○	1.25	35	41		2	○	2.90	38	60						
	2	○	2.00	38	60		3	○	3.90	42	55						
	3	○	2.50	38	67		4▽	○	6.92	42	70						
	4▽	○	2.90	38	70		5▽	○	7.58	48	75						
	5▽	○	3.60	38	75		6▽	○	11.40	48	85						
100◆	1	○	1.32	32	41	150	1	○	2.43	32	43						
	2	○	2.11	38	60		2	○	3.24	38	48						
	3	○	2.85	38	55		3	○	4.28	42	60						
	4▽	○	3.81	38	70		4▽	○	6.76	42	70						
	5▽	○	4.45	38	75		5▽	○	8.43	48	75						
	6▽	○	5.20	38	124		6▽	○	12.10	48	85						
106◆	1	○	1.45	28	41	160	1	x	2.50	38	43						
	2	○	2.00	28	60		2	x	3.32	42	48						
	3	○	3.00	30	55		3	x	4.60	48	60						
	4▽	○	4.30	30	70		4▽	○	7.01	48	70						
	5▽	○	5.10	32	75		5▽	○	9.35	48	75						
	6▽	○	6.00	32	124		6▽	○	12.85	55	85						
												170	1	x	2.85	42	43
													2	x	3.44	42	48
													3	x	4.89	42	60
													4▽	○	7.20	48	70
													5▽	○	8.90	48	75
6▽	○	13.10	48	85													

▲ for profile B/17 ◆ for profile BX/X17 ■ for profile XPB

▽ $d_d + 5.5$ mm

Number of grooves z	1	2	3	4	5	6
Face width b_2 [mm]	25	44	63	86	105	124

● Solid pulley
 ○ Plate pulley (with or without holes)
 x Spoked pulley
 Hub position: flush one-sided
 Material: EN-GJL-200 (GG 20) – DIN EN 1561

STANDARD RANGE

optibelt **KS** V-GROOVED PULLEYS FOR CYLINDRICAL BORES – GROOVE ACCORDING TO DIN 2211

Profile SPB/B/17											
Datum diameter d_d [mm]	Number of grooves	Design	Weight [≈ kg]	Finished bore d_{max} [mm]	Hub length [mm]	Datum diameter d_d [mm]	Number of grooves	Design	Weight [≈ kg]	Finished bore d_{max} [mm]	Hub length [mm]
180	1	x	3.10	38	43	315	1	x	6.40	48	49
	2	x	3.90	42	48		2	x	8.22	55	55
	3	x	5.28	48	60		3	x	12.90	55	67
	4▽	x	7.42	48	70		4▽	x	13.00	60	80
	5▽	○	9.05	55	75		5▽	x	17.60	65	80
	6▽	○	10.80	60	85		6▽	x	20.60	75	90
190	1	x	3.19	42	43	355	1	x	7.00	48	49
	2	x	4.22	42	48		2	x	9.70	55	55
	3	x	5.49	42	60		3	x	13.40	55	67
	4▽	x	7.69	48	70		4▽	x	18.25	60	80
	5▽	○	9.22	50	75		5▽	x	18.75	65	75
	6▽	○	11.95	55	85		6▽	x	19.75	75	90
200	1	x	3.40	38	43	400	1▽	x	8.46	50	49
	2	x	4.45	42	48		2▽	x	10.00	55	55
	3	x	5.85	48	60		3▽	x	14.30	60	67
	4▽	x	7.98	50	60		4▽	x	18.50	65	80
	5▽	○	9.50	55	80		5▽	x	22.50	70	85
	6▽	○	12.20	60	90		6▽	x	28.00	75	90
212	1	x	3.75	42	43	450	1▽	x	9.86	50	55
	2	x	4.66	42	48		2▽	x	10.87	55	55
	3	x	6.15	48	60		3▽	x	15.05	60	67
	4▽	x	7.70	50	70		4▽	x	20.50	65	80
	5▽	x	10.30	50	80		5▽	x	26.00	70	80
	6▽	○	13.51	55	90		6▽	x	28.90	75	90
224	1	x	4.00	42	43	500	1▽	x	10.70	50	55
	2	x	5.40	42	48		2▽	x	13.70	60	59
	3	x	6.90	48	60		3▽	x	15.20	65	67
	4▽	x	8.64	55	70		4▽	x	21.30	70	80
	5▽	○	11.72	50	90		5▽	x	30.00	75	80
	6▽	○	14.75	55	90		6▽	x	33.80	80	90
250	1	x	4.20	42	43	560	2▽	x	15.00	60	55
	2	x	6.10	48	55		3▽	x	24.20	65	67
	3	x	8.60	55	60		4▽	x	26.20	70	80
	4▽	x	9.70	60	70		5▽	x	34.40	75	80
	5▽	x	13.20	65	80		6▽	x	39.00	80	90
	6▽	x	17.00	65	90		630	2▽	x	20.20	60
280	1	x	5.70	48	49	3▽		x	27.00	65	80
	2	x	7.04	48	55	4▽		x	30.80	75	86
	3	x	9.67	55	60	5▽		x	37.20	80	90
	4▽	x	11.52	60	70	6▽		x	44.00	90	100
	5▽	x	15.50	65	80						
	6▽	x	18.00	65	90						
300	1	x	5.90	48	49						
	2	x	7.50	48	55						
	3	x	10.50	55	67						
	4▽	x	12.40	60	80						
	5▽	x	15.40	65	80						
	6▽	x	18.25	70	90						
▽ $d_d + 5.5$ mm											

Number of grooves z	1	2	3	4	5	6
Face width b_2 [mm]	25	44	63	86	105	124

● Solid pulley
 ○ Plate pulley (with or without holes)
 x Spoked pulley
 Hub position: flush one-sided
 Material: EN-GJL-200 (GG 20) – DIN EN 1561

STANDARD RANGE

optibelt **KS** V-GROOVED PULLEYS FOR CYLINDRICAL BORES – GROOVE ACCORDING TO DIN 2211

Profile SPC/C/22											
Datum diameter d_d [mm]	Number of grooves	Design	Weight [≈ kg]	Finished bore d_{max} [mm]	Hub length l [mm]	Datum diameter d_d [mm]	Number of grooves	Design	Weight [≈ kg]	Finished bore d_{max} [mm]	Hub length l [mm]
180▲◆■	1	○	4.20	40	54	450	2	x	21.10	70	80
	2	○	7.20	50	64		3	x	26.30	75	90
	3	○	10.40	55	90		4	x	31.10	75	105
	4	○	10.50	55	95		5	x	42.20	80	110
	5	○	18.00	60	100		6	x	48.50	80	120
	6	○	23.70	65	115						
200▲◆■	1	○	4.80	40	54	500	3	x	28.40	75	90
	2	○	7.80	50	64		4	x	34.10	75	105
	3	○	10.60	55	90		5	x	48.20	80	110
	4	○	11.20	60	95	560	6	x	52.50	80	120
	5	○	15.40	65	100		3	x	31.10	75	90
	6	○	27.00	70	125		4	x	39.00	75	105
225	1	x	5.50	48	54	630	5	x	54.10	85	110
	2	x	7.80	52	64		6	x	61.50	85	120
	3	x	10.60	52	90		3	x	38.50	80	90
	4	x	13.10	55	95		4	x	48.10	80	105
	5	x	16.70	60	100		5	x	62.20	85	110
	6	x	35.00	60	115		6	x	73.20	85	120
250	1	x	7.30	52	54						
	2	x	8.80	52	64						
	3	x	11.10	65	90						
	4	x	15.30	70	95						
	5	x	19.00	75	100						
	6	x	23.70	60	115						
280	1	x	8.70	52	54						
	2	x	10.90	55	64						
	3	x	15.60	70	90						
	4	x	17.50	75	95						
	5	x	20.50	75	100						
315	1	x	9.10	52	54						
	2	x	13.00	55	74						
	3	x	17.10	70	90						
	4	x	20.00	75	95						
	5	x	24.70	80	100						
	6	x	31.20	85	115						
335	2	x	14.00	55	74						
	3	x	18.30	55	90						
	4	x	22.40	60	95						
	5	x	28.30	65	100						
	6	x	34.40	75	115						
	355	2	x	15.20	60	74					
3		x	19.20	70	90						
4		x	25.80	70	95						
5		x	32.00	75	100						
6		x	36.20	75	115						
400		3	x	20.60	70	90					
	4	x	28.00	70	105						
	5	x	32.00	75	100						

▲ for profile C/22 ◆ for profile CX/X22 ■ for profile XPC

Number of grooves z	1	2	3	4	5	6
Face width b_2 [mm]	38	64	90	116	142	168

● Solid pulley
 ○ Plate pulley (with or without holes)
 x Spoked pulley
 Hub position: flush one-sided
 Material: EN-GJL-200 (GG 20) – DIN EN 1561

STANDARD RANGE

optibelt **TB** TAPER BUSHES

Taper bushes with metrical bore, groove according to DIN 6885 Part 1																
	Taper bush										Material: EN-GJL-200 – DIN EN 1561					
	1008	1108	1210	1215	1310	1610	1615	2012	2517	3020	3030	3525	3535	4040	4545	5050
Bore diameter d ₂ [mm]	10	10	11	11	14	14	14	14	16	25	35	35	35	40	55	70
	11	11	12	12	16	16	16	16	18	28	38	38	38	42	60	75
	12	12	14	14	18	18	18	18	19	30	40	40	40	45	65	80
	14	14	16	16	19	19	19	19	20	32	42	42	42	48	70	85
	16	16	18	18	20	20	20	20	22	35	45	45	45	50	75	90
	18	18	19	19	22	22	22	22	24	38	48	48	48	55	80	95
	19	19	20	20	24	24	24	24	25	40	50	50	50	60	85	100
	20	20	22	22	25	25	25	25	28	42	55	55	55	65	90	105
	22	22	24	24	28	28	28	28	30	45	60	60	60	70	95	110
	24▲	24	25	25	30	30	30	30	32	48	65	65	65	75	100	115
	25▲	25	28	28	32	32	32	32	35	50	70	70	70	80	105	120
		28▲	30	30	35	35	35	35	38	55	75	75	75	85	110	125
			32	32		38	38	38	40	60	80	80	80	90		
						40	40	40	42	65	85	85	85	95		
						42▲	42▲	42	45	70	90	90	90	100		
								45	48	75						
								48	50							
								50	55							
								60								
Hexagonal socket screw [inch]	1/4 x 1/2	1/4 x 1/2	3/8 x 5/8	3/8 x 5/8	3/8 x 5/8	3/8 x 5/8	3/8 x 5/8	7/16 x 7/8	1/2 x 1	5/8 x 1 1/4	5/8 x 1 1/4	1/2 x 1 1/2	1/2 x 1 1/2	5/8 x 1 3/4	3/4 x 2	7/8 x 2 1/4
Tightening torque [Nm]	5.7	5.7	20	20	20	20	20	31	49	92	92	115	115	172	195	275
Bush length [mm]	22.3	22.3	25.4	38.1	25.4	25.4	38.1	31.8	44.5	50.8	76.2	63.5	88.9	101.6	114.3	127.0
Weight for d _{2 min} [≈ kg]	0.12	0.16	0.28	0.39	0.32	0.41	0.60	0.75	1.06	2.50	3.75	3.90	5.13	7.68	12.70	15.17

From 3525: Cylinder head screw with hexagonal socket ▲ This is a shallow keyway bore.

Shallow keyways for taper bushes

Bore diameter d ₂ [mm]	Groove width b [mm]	Groove depth t ₂ [mm]	Bore diameter d ₂ [mm]	Groove width b [mm]	Groove depth t ₂ [mm]
24	8	2.0	28	8	2.0
25	8	1.3	42	12	2.2

Taper bushes with imperial bores, groove according to British Standard BS 46 Part 1																
	Taper bush										Material: EN-GJL-200 – DIN EN 1561					
	1008	1108	1210	1215	1310	1610	1615	2012	2517	3020	3030	3525	3535	4040	4545	5050
Bore diameter d ₂ [inch]	3/8*	3/8*	1/2	5/8*	1/2*	1/2	1/2	5/8*	3/4	1 1/4	1 1/4	1 1/2	1 1/2	1 3/4*	2 1/4*	3*
	1/2	1/2	5/8	3/4	5/8*	5/8	5/8	3/4	7/8	1 3/8	1 3/8	1 5/8	1 5/8	1 7/8*	2 3/8*	3 1/4*
	5/8	5/8	3/4	7/8	3/4*	3/4	3/4	7/8	1	1 1/2	1 3/4	1 3/4	1 3/4	2*	2 1/2*	3 1/2*
	3/4	3/4	7/8	1	7/8*	7/8	7/8*	1	1 1/8	1 5/8	1 5/8	1 7/8	1 7/8	2 1/8*	2 3/4*	3 3/4*
	7/8	7/8	1	1 1/8	1*	1	1	1 1/8	1 1/4	1 3/4*	1 3/4*	2	2	2 1/4*	2 7/8*	4*
	1▲	1	1 1/8	1 1/4	1 1/8	1 1/8	1 1/8	1 1/4	1 3/8	1 7/8	1 7/8	2 1/8	2 1/8	2 3/8*	3*	4 1/4*
		1 1/8▲*	1 1/4		1 1/4	1 1/4	1 1/4	1 3/8	1 1/2	2	2	2 1/4	2 1/4	2 1/2*	3 1/4*	4 1/2*
					1 3/8	1 3/8	1 3/8	1 1/2	1 5/8	2 1/8*	2 1/8*	2 3/8	2 3/8	2 5/8*	3 3/8*	4 3/4*
					1 1/2	1 1/2	1 1/2	1 5/8	1 3/4	2 1/4	2 1/4	2 1/2	2 1/2	2 3/4*	3 1/2*	5▲*
					1 5/8	1 5/8▲*	1 5/8	1 3/4	1 7/8	2 3/8	2 3/8	2 5/8	2 5/8	2 7/8*	3 3/4*	
								1 7/8	2	2 1/2	2 1/2	2 3/4	2 3/4	3*	4*	
								2	2 1/8	2 5/8	2 5/8*	2 7/8	2 7/8	3 1/8*	4 1/4▲*	
								2 1/4	2 3/4	2 3/4	2 3/4*	3	3	3 1/4*	4 1/2▲*	
								2 3/8	2 7/8	2 7/8	3	3 1/8	3 1/8	3 3/8*		
								2 1/2	3	3	3	3 1/4	3 1/4	3 1/2*		
												3 3/8	3 3/8	3 3/4▲*		
												3 1/2▲	3 1/2▲	4▲*		
Hexagonal socket screw [inch]	1/4 x 1/2	1/4 x 1/2	3/8 x 5/8	3/8 x 5/8	3/8 x 5/8	3/8 x 5/8	3/8 x 5/8	7/16 x 7/8	1/2 x 1	5/8 x 1 1/4	5/8 x 1 1/4	1/2 x 1 1/2	1/2 x 1 1/2	5/8 x 1 3/4	3/4 x 2	7/8 x 2 1/4
Tightening torque [Nm]	5.7	5.7	20	20	20	20	20	31	49	92	92	115	115	172	195	275
Bush length [mm]	22.3	22.3	25.4	38.1	25.4	25.4	38.1	31.8	44.5	50.8	76.2	63.5	88.9	101.6	114.3	127.0
Weight for d _{2 min} [≈ kg]	0.12	0.16	0.28	0.39	0.32	0.41	0.60	0.75	1.06	2.50	3.75	3.90	5.13	7.68	12.70	15.17

From 3525: Cylinder head screw with hexagonal socket * Non stock item ▲ This is a shallow keyway bore.

DRIVE CALCULATION

EXPLANATION OF SYMBOLS

a	= drive centre distance provisional	[mm]	L_{ith}	= calculated inside belt length	[mm]
a_{nom}	= drive centre distance calculated with a standard belt length	[mm]	L_{dSt}	= standard belt datum length	[mm]
b_d	= datum width		L_{dth}	= calculated belt datum length	[mm]
b_1	= top width		n_g	= speed of the larger pulley	[min ⁻¹]
c_1	= arc of contact correction factor		n_k	= speed of the smaller pulley	[min ⁻¹]
c_2	= service factor		n_1	= speed of the driver pulley	[min ⁻¹]
c_3	= belt length factor		n_2	= speed of the driven pulley	[min ⁻¹]
c_4	= number of idlers factor		P	= motor or normal running power	[kW*]
d_{dg}	= datum diameter of large pulley (DIN 2211 Sheet 1, Table 2)	[mm]	P_B	= design power	[kW*]
d_{dk}	= datum diameter of small pulley (DIN 2211 Sheet 1, Table 2)	[mm]	P_N	= nominal power rating per belt	[kW*]
d_{d1}	= datum diameter of the driver pulley	[mm]	S_a	= minimum static shaft loading	[N]
d_{d2}	= datum diameter of the driven pulley	[mm]	T	= minimum static tension per belt	[N]
E	= belt deflection per 100 mm span length	[mm]	v	= belt speed	[m/s]
E_a	= belt deflection for a given span length	[mm]	x	= minimum allowance above centre distance a_{nom} for belt stretch and wear	[mm]
f	= load used to set belt tension	[N]	y	= minimum allowance below centre distance a_{nom} for easy belt fitting	[mm]
f_B	= flex rate	[s ⁻¹]	z	= number of belts	
i	= drive ratio		α	= angle of belt drive = $90^\circ - \frac{\beta}{2}$	[°]
k	= constant for calculating centrifugal force in belt set		β	= arc of contact on small pulley	[°]
L	= span length	[mm]			
L_{iSt}	= standard inside belt length	[mm]			

* 1 kW = 1 kNm/s

The terms pitch diameter (d_w), pitch length (L_w) and pitch circumference (U_w) used previously have been changed to datum diameter (d_d), datum length (L_d) and datum circumference (U_d) in order to bring them into line with current standard terminology.

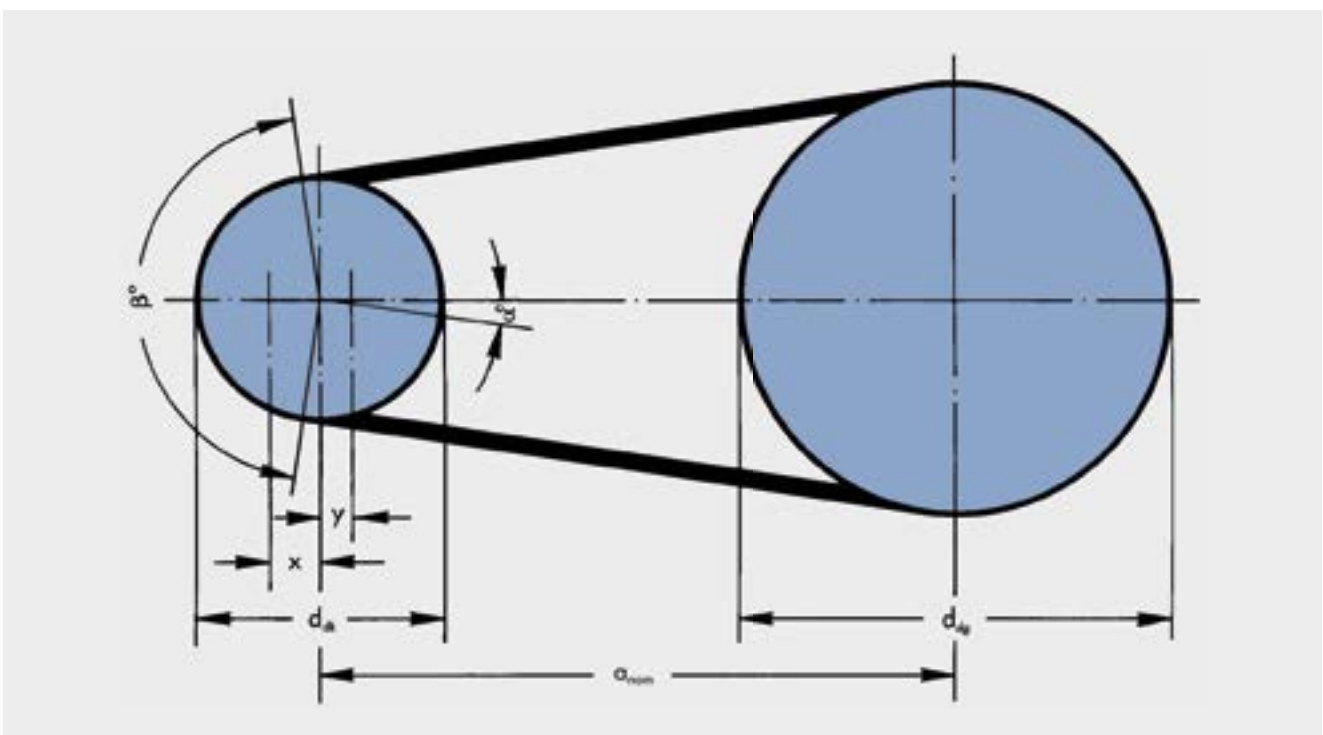

DRIVE CALCULATION

OPTIBELT NOMINAL POWER RATING P_N – ARC OF CONTACT CORRECTION FACTOR c_1

The OPTIBELT nominal power ratings P_N in tables 32 to 68 are based upon an internationally accepted basic formula and a theoretical belt life of 25,000 hours under ideal conditions. This formula contains material constants that take into account the quality of the raw materials used and make allowances for production methods. Due to the special qualities of OPTIBELT V-belts, other material constants than those given in DIN have been taken into account. As a result, the nominal OPTIBELT power ratings P_N significantly exceed the ratings given, for wedge belts according to DIN 7753 Part 2 and for classic V-belts according to DIN 2218, for the same theoretical belt life. The nominal power ratings P_N are based on the smallest loaded pulley in the drive system. The belt power rating value P_N is calculated taking into account

- the datum diameter of the smaller pulley d_{dk}
- the speed of the smaller pulley n_k
- the drive ratio i
- an assumed arc of contact at the smaller pulley of $\beta = 180^\circ$
- a reference belt length for the specific belt profile

In order to account for the actual drive data, based on the arc of contact and the belt lengths employed, correction factors for the arc of contact c_1 and length c_3 have been introduced. If required, drive calculations can be provided for any theoretical belt life.

Intermediate values for nominal power rating, arc of contact and length correction factors can be found via linear interpolation.

The factor c_1 corrects the power rating P_N , when the arc of contact is smaller than 180° , as the P_N value is calculated on the arc of contact $\beta = 180^\circ$ on the smaller pulley.

Table 22

$\frac{d_{dg} - d_{dk}}{a_{nom}}$	$\beta \approx$	c_1
0	180°	1.00
0.05	177°	1.00
0.10	174°	1.00
0.15	171°	1.00
0.20	168°	0.99
0.25	165°	0.99
0.30	162°	0.99
0.35	160°	0.99
0.40	156°	0.99
0.45	153°	0.98
0.50	150°	0.98
0.55	147°	0.98
0.60	144°	0.98
0.65	141°	0.97
0.70	139°	0.97
0.75	136°	0.97
0.80	133°	0.96
0.85	130°	0.96
0.90	126°	0.96
0.95	123°	0.95
1.00	119°	0.94
1.05	115°	0.94
1.10	112°	0.93
1.15	109°	0.93
1.20	106°	0.92
1.25	103°	0.91
1.30	100°	0.91
1.35	96°	0.90
1.40	92°	0.88
1.45	88°	0.87
1.50	84°	0.86
1.55	80°	0.84
1.60	77°	0.83

DRIVE CALCULATION

LOAD FACTOR c_2

The service factor c_2 takes account of the daily operating time and of the type of driver and driven machine. It applies exclusively to two-pulley drives. Other arrangements such as drives with tension and guide idlers have not been taken into consideration. Pages 129-131 provide the relevant basic design guidelines for drives with more than two pulleys. Adverse operating conditions (e.g. aggressive dust, particularly high ambient temperatures or the effects of various substances) **have not** been taken into account. As it is practically impossible to cover every conceivable combination of driver/driven machine/operating conditions in a summary that complies with the relevant standards, the service factors are **approximate values**.

In special cases, e.g. increased starting torque (direct on-line starting of fans), in drives with frequent starts and stops, in systems subject to exceptional shock loads, or when significant masses are to be accelerated or braked, the service factor must be increased.

Empirical value:

With a starting torque > 1.8 this figure is to be divided by 1.5 in order to calculate the minimum load factor c_2 .

Example: Starting torque MA = 3.0; c_2 selected 2.0.

Please consult our Applications Engineering Department for the solution of special problems.

Table 23

Examples for Work Machines	Examples for Drive Machines					
	Load factor c_2 for daily operating time (hours)			Load factor c_2 for daily operating time (hours)		
	up to 10	over 10 to 16	over 16	up to 10	over 10 to 16	over 16
Light drives Centrifugal pumps and compressors, belt conveyors (light weight materials), fans and pumps up to 7.5 kW.	1.1	1.1	1.2	1.1	1.2	1.3
Medium drives Plate cutters, presses, chain and belt conveyors (heavy materials), vibrating screens, generators and exciters, bakery machinery, machine tools (lathes and grinders), laundry machines, printing machinery, fans and pumps over 7.5 kW.	1.1	1.2	1.3	1.2	1.3	1.4
Heavy drives Crushing plants, piston compressors, heavy-duty conveyors, directional throw conveyors, push conveyors (screw, plate belts, bucket and shovel conveyors), lifts, briquette presses, textile machinery, paper machinery, piston pumps, excavator pumps, log frame saws, hammer mills.	1.2	1.3	1.4	1.4	1.5	1.6
Very heavy drives Heavy-duty mills, stone crushers, calenders, mixers, winches, cranes, excavators, heavy-duty wood working machinery.	1.3	1.4	1.5	1.5	1.6	1.8

DRIVE CALCULATION

LENGTH FACTOR c_3 FOR OPTIBELT WEDGE BELTS AND KRAFTBANDS

The length factor c_3 takes into account the flex rate of the belt based on the reference length for the particular belt profile.

This results in the following relationships:

belt length > reference length $c_3 > 1.0$
 belt length = reference length $c_3 = 1.0$
 belt length < reference length $c_3 < 1.0$

Table 24

Profile SPZ, XPZ		Profile SPA, XPA		Profile SPB, XPB		Profile SPC, XPC	
Datum length [mm]	c_3	Datum length [mm]	c_3	Datum length [mm]	c_3	Datum length [mm]	c_3
630	0.83	800	0.81	1250	0.83	2000	0.85
670	0.84	850	0.82	1320	0.84	2120	0.86
710	0.85	900	0.83	1400	0.85	2240	0.86
750	0.86	950	0.84	1500	0.86	2360	0.87
800	0.87	1000	0.85	1600	0.87	2500	0.88
850	0.88	1060	0.86	1700	0.88	2650	0.89
900	0.89	1120	0.86	1800	0.89	2800	0.90
950	0.90	1180	0.87	1900	0.90	3000	0.91
1000	0.91	1250	0.88	2000	0.91	3150	0.91
1060	0.92	1320	0.89	2120	0.92	3350	0.92
1120	0.93	1400	0.90	2240	0.93	3550	0.93
1180	0.94	1500	0.91	2360	0.93	3750	0.94
1250	0.95	1600	0.92	2500	0.94	4000	0.95
1320	0.96	1700	0.93	2650	0.95	4250	0.96
1400	0.98	1800	0.94	2800	0.96	4500	0.97
1500	0.99	1900	0.95	3000	0.97	4750	0.98
1600	1.00	2000	0.96	3150	0.98	5000	0.98
1700	1.01	2120	0.97	3350	0.99	5300	0.99
1800	1.02	2240	0.98	3550	1.00	5600	1.00
1900	1.03	2360	0.99	3750	1.01	6000	1.01
2000	1.04	2500	1.00	4000	1.02	6300	1.02
2120	1.05	2650	1.01	4250	1.03	6700	1.03
2240	1.06	2800	1.02	4500	1.04	7100	1.04
2360	1.07	3000	1.03	4700	1.04	7500	1.04
2500	1.08	3150	1.04	5000	1.05	8000	1.05
2650	1.09	3350	1.05	5300	1.06	8500	1.06
2800	1.10	3550	1.06	5600	1.07	9000	1.07
3000	1.11	3750	1.07	6000	1.08	9500	1.08
3150	1.12	4000	1.08	6300	1.09	10000	1.09
3350	1.13	4250	1.09	6700	1.10	10600	1.09
3550	1.15	4500	1.10	7100	1.11	11200	1.10
3750	1.16	4750	1.11	7500	1.12	11800	1.11
4000	1.17	5000	1.12	8000	1.13	12500	1.12
4250	1.18	5300	1.13	8500	1.14	13200	1.13
4500	1.19	5600	1.14	9000	1.15	14000	1.14
		6000	1.15	9500	1.16	15000	1.15
				10000	1.17		

DRIVE CALCULATION

LENGTH FACTOR c_3 FOR OPTIBELT WEDGE BELTS AND KRAFTBANDS

Table 25

Profile 3V/9N, 3VX/9NX 3V/9J, 3VX/9JX			Profile 5V/15N, 5VX/15NX 5V/15J, 5VX/15JX			Profile 8V/25N 8V/25J		
Belt designation	Outside length [mm]	c_3	Belt designation	Outside length [mm]	c_3	Belt designation	Outside length [mm]	c_3
3V 265	673	0.84	5V 500	1270	0.84	8V 1000	2540	0.87
3V 280	711	0.85	5V 530	1346	0.85	8V 1060	2692	0.87
3V 300	762	0.86	5V 560	1422	0.85	8V 1120	2845	0.88
3V 315	800	0.87	5V 600	1524	0.87	8V 1180	2997	0.89
3V 335	851	0.88	5V 630	1600	0.87	8V 1250	3175	0.90
3V 355	902	0.90	5V 670	1702	0.88	8V 1320	3353	0.91
3V 375	952	0.91	5V 710	1803	0.89	8V 1400	3556	0.92
3V 400	1016	0.92	5V 750	1905	0.90	8V 1500	3810	0.93
3V 425	1079	0.93	5V 800	2032	0.91	8V 1600	4064	0.93
3V 450	1143	0.94	5V 850	2159	0.92	8V 1700	4318	0.94
3V 475	1206	0.95	5V 900	2286	0.93	8V 1800	4572	0.95
3V 500	1270	0.96	5V 950	2413	0.94	8V 1900	4826	0.96
3V 530	1346	0.97	5V 1000	2540	0.95	8V 2000	5080	0.97
3V 560	1422	0.98	5V 1060	2692	0.96	8V 2120	5385	0.98
3V 600	1524	0.99	5V 1120	2845	0.96	8V 2240	5690	0.98
3V 630	1600	1.00	5V 1180	2997	0.97	8V 2360	5994	0.99
3V 670	1702	1.01	5V 1250	3175	0.98	8V 2500	6350	1.00
3V 710	1803	1.02	5V 1320	3353	0.99	8V 2650	6731	1.01
3V 750	1905	1.03	5V 1400	3556	1.00	8V 2800	7112	1.02
3V 800	2032	1.04	5V 1500	3810	1.01	8V 3000	7620	1.03
3V 850	2159	1.05	5V 1600	4064	1.02	8V 3150	8001	1.03
3V 900	2286	1.07	5V 1700	4318	1.03	8V 3350	8509	1.04
3V 950	2413	1.07	5V 1800	4572	1.04	8V 3550	9017	1.05
3V 1000	2540	1.08	5V 1900	4826	1.05	8V 3750	9525	1.06
3V 1060	2692	1.09	5V 2000	5080	1.06	8V 4000	10160	1.07
3V 1120	2845	1.11	5V 2120	5385	1.07	8V 4250	10795	1.08
3V 1180	2997	1.11	5V 2240	5690	1.07	8V 4500	11430	1.09
3V 1250	3175	1.13	5V 2360	5994	1.08	8V 4750	12065	1.09
3V 1320	3353	1.14	5V 2500	6350	1.09	8V 5000	12700	1.10
3V 1400	3556	1.15	5V 2650	6731	1.10	8V 5300	13462	1.11
3V 1500	3810	1.16	5V 2800	7112	1.11	8V 5600	14224	1.12
3V 1600	4064	1.17	5V 3000	7620	1.12	8V 6000	15240	1.13
3V 1700	4318	1.18	5V 3150	8001	1.13	8V 6300	16002	1.13
3V 1800	4572	1.19	5V 3350	8509	1.14			
3V 1900	4826	1.20	5V 3550	9017	1.15			
3V 2000	5080	1.21	5V 3750	9525	1.16			
			5V 4000	10160	1.17			

DRIVE CALCULATION

GUIDELINES FOR SELECTING THE SUITABLE PROFILES FOR V-BELTS AND KRAFTBANDS

By using the following diagrams, the most suitable belt profiles as far as efficiency and size are concerned, can be selected for a specific application. The most efficient power transmission and economy is achieved by selecting as large a pulley diameter as possible for the profile in question. The limits to be observed are the maximum allowed circumferential speed, namely for

high performance wedge belts $v_{max} = 55 \text{ m/s}^*$;
for classic V-belts $v_{max} = 30 \text{ m/s}$.

If the circumferential speed is outside this recommendation, please contact our Application Engineering Department. Experience has shown that minimum pulley diameters should be avoided. These drives require a larger number of belts with wider pulleys and are therefore more expensive.

In borderline cases we recommend using the next smaller profile belt for the same pulley diameter, as the smaller profile will often save both cost and space. A further recommended solution is the use of the raw edge optibelt SUPER X-POWER M=S V-belts.

Furthermore, we recommend evaluating if the intersection point in the selection diagram is in the limit values of two profiles.

Comparing space requirement and costs, the high performance wedge belt is usually far superior to classic V-belts in almost all industrial drives. For this reason, new constructions use high performance wedge belts almost exclusively. Only in special cases, for replacement parts, or for V-flat drives or special cases where the application of classic V-belts is obligatory.

Diagram 1: optibelt VB classic V-belts DIN 2215

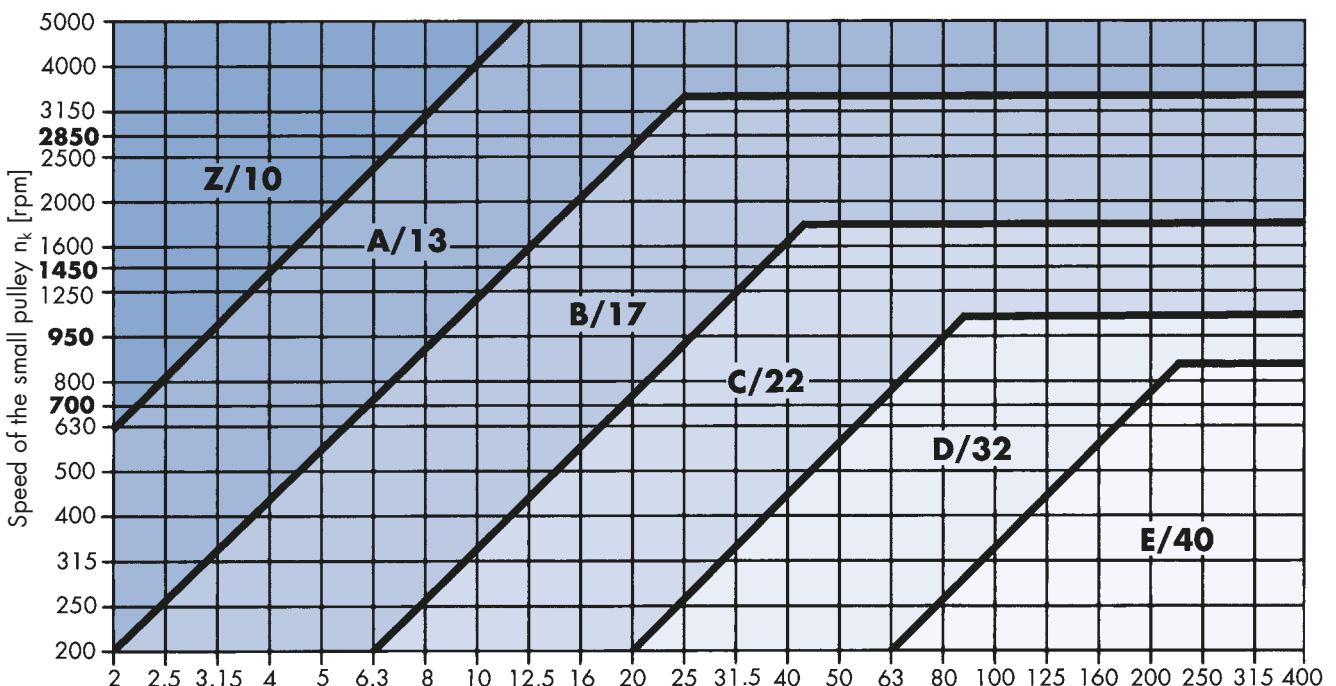

Design power $P_B = P \cdot c_2$ [kW]

* $v > 42 \text{ m/sec}$. Please consult our Application Engineering Department.

DRIVE CALCULATION

GUIDELINES FOR SELECTING THE SUITABLE PROFILES FOR V-BELTS AND KRAFTBANDS

Diagram 2: optibelt SK high performance wedge belts DIN 7753 Part 1

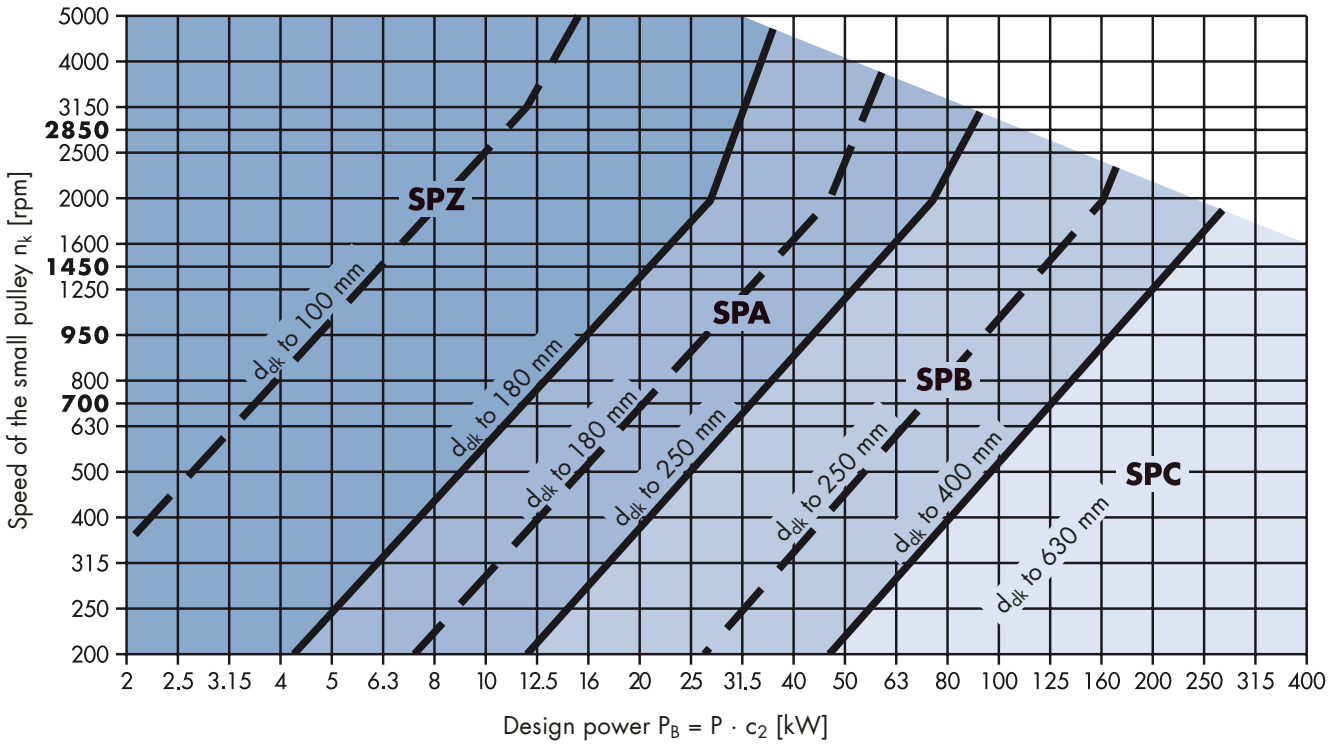
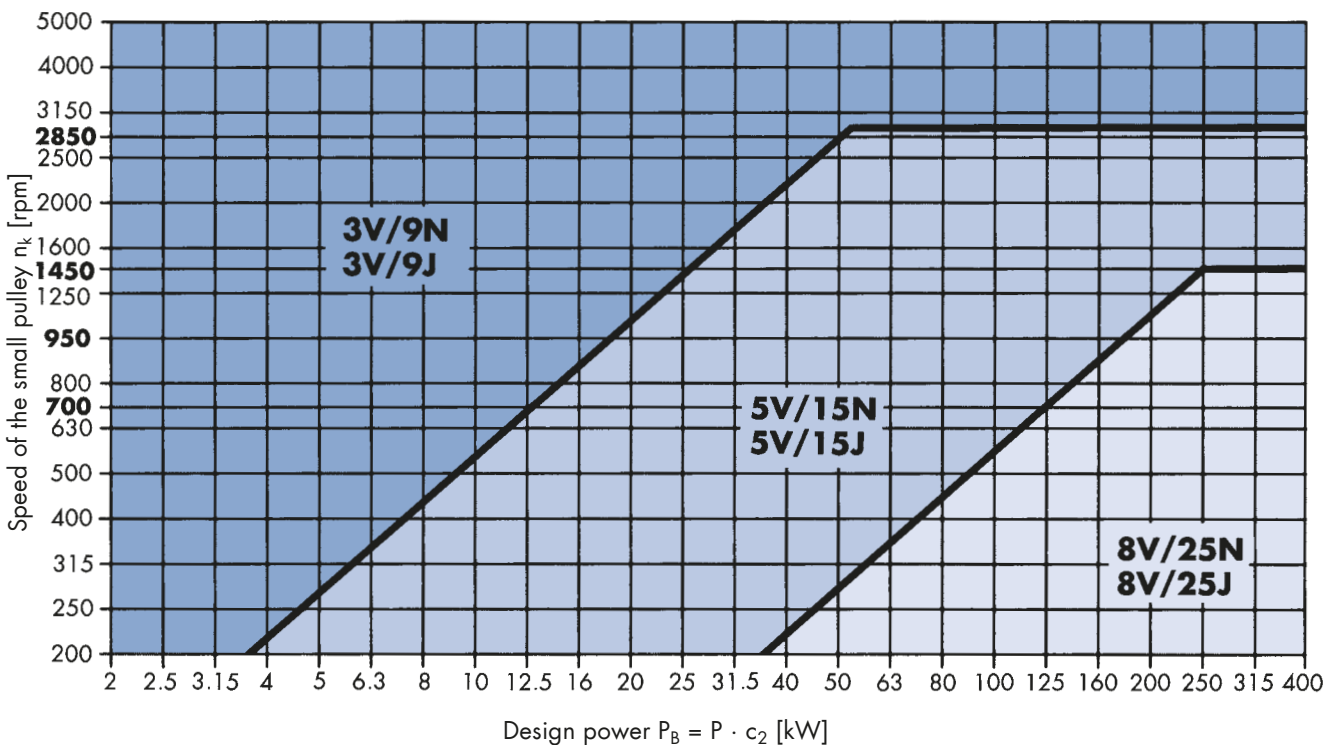

Diagram 3: optibelt SK high performance wedge belts USA standard RMA/MPTA



DRIVE CALCULATION

GUIDELINES FOR SELECTING THE SUITABLE PROFILES FOR V-BELTS AND KRAFTBANDS

Diagram 4: optibelt SUPER X-POWER M=S wedge belts

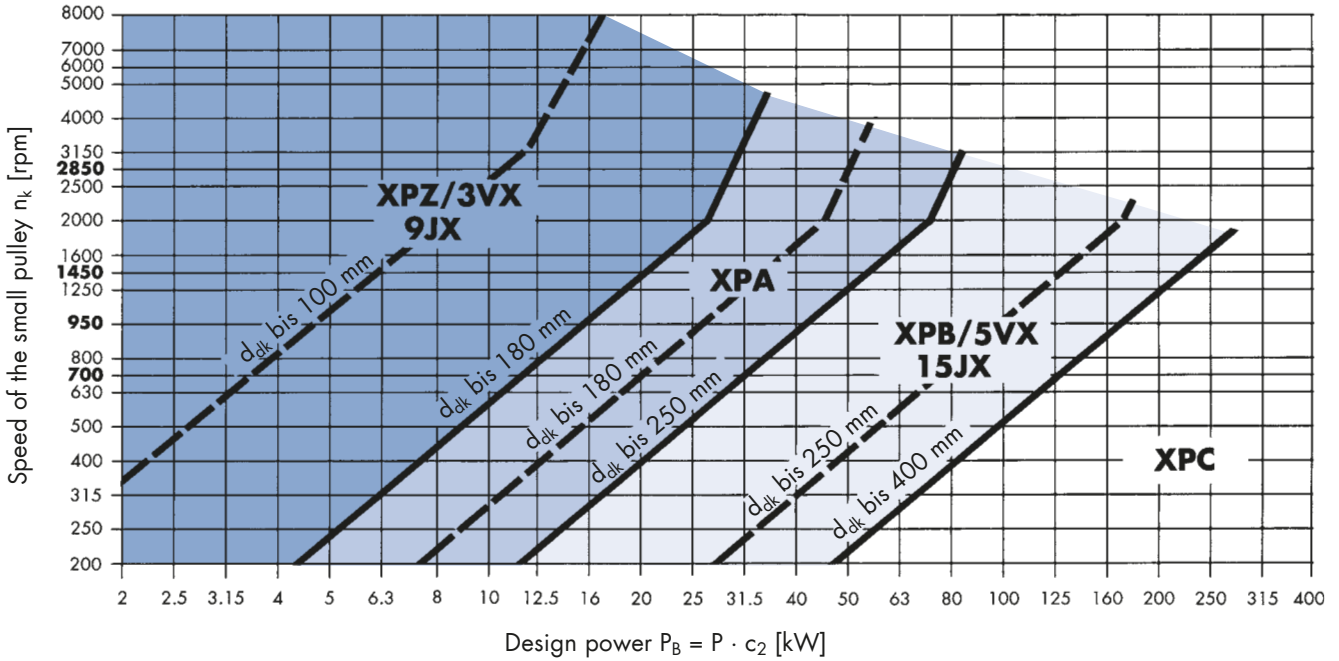
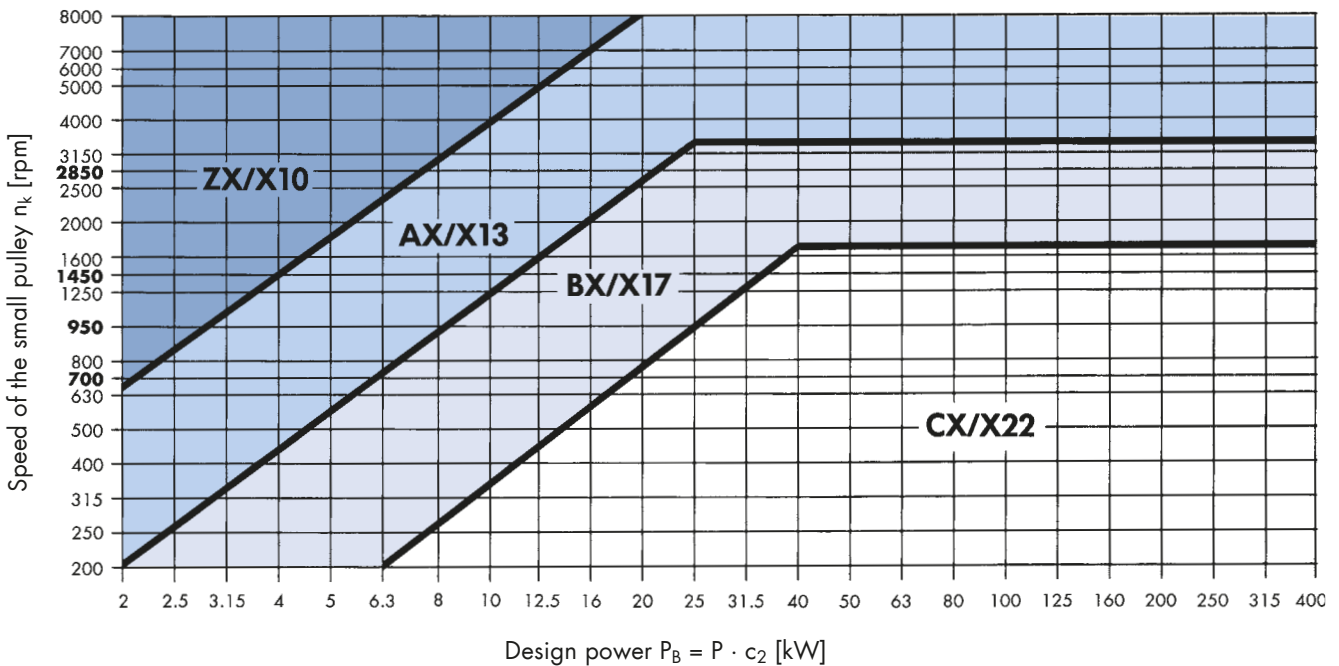

Diagram 5: optibelt SUPER TX M=S V-belts



DRIVE CALCULATION

MINIMUM ALLOWANCE X/Y FOR ADJUSTING CENTRE DISTANCE a_{nom}

Table 27: optibelt SK wedge belts

Datum length [mm]	Minimum allowance x [mm] – for tensioning	Minimum allowance y [mm] – for easy fitting			
		SPZ, XPZ	SPA, XPA	SPB, XPB	SPC, XPC
487 ≤ 670	10	10	10	–	–
> 670 ≤ 1 000	15	15	15	–	–
> 1 000 ≤ 1 250	20	15	15	–	–
> 1 250 ≤ 1 800	25	20	20	20	–
> 1 800 ≤ 2 240	25	20	20	20	25
> 2 240 ≤ 3 000	35	20	20	20	30
> 3 000 ≤ 4 000	45	20	20	20	30
> 4 000 ≤ 5 000	55	20	20	25	30
> 5 000 ≤ 6 300	70	25	25	30	35
> 6 300 ≤ 8 000	85	25	25	35	40
> 8 000 ≤ 10 000	110	30	30	35	45
> 10 000 ≤ 12 500	135	–	–	35	45
> 12 500 ≤ 15 000	150	–	–	45	55
> 15 000 ≤ 18 000	190	–	–	45	55

Table 28: optibelt SK wedge belts

Datum length	Outside length [mm]	Minimum allowance x [mm] – for tensioning	Minimum allowance y [mm] – for easy fitting		
			3V/9N, 3VX/9NX	5V/15N, 5VX/15NX	8V/25N
> 265 ≤ 400	> 673 ≤ 1 016	15	15	–	–
> 400 ≤ 475	> 1 016 ≤ 1 206	20	15	–	–
> 475 ≤ 710	> 1 206 ≤ 1 803	25	20	20	–
> 710 ≤ 850	> 1 803 ≤ 2 159	25	20	20	–
> 850 ≤ 1 180	> 2 159 ≤ 2 997	35	20	20	40
> 1 180 ≤ 1 600	> 2 997 ≤ 4 064	45	20	20	40
> 1 600 ≤ 2 000	> 4 064 ≤ 5 080	55	20	25	40
> 2 000 ≤ 2 500	> 5 080 ≤ 6 350	70	–	30	45
> 2 500 ≤ 3 150	> 6 350 ≤ 8 001	85	–	35	45
> 3 150 ≤ 4 000	> 8 001 ≤ 10 160	110	–	35	50
> 4 000 ≤ 5 000	> 10 160 ≤ 12 700	135	–	35	50
> 5 000 ≤ 6 000	> 12 700 ≤ 15 240	150	–	45	60
> 6 000 ≤ 7 100	> 15 240 ≤ 18 034	190	–	45	60

DRIVE CALCULATION

MINIMUM ALLOWANCE X/Y FOR ADJUSTING CENTRE DISTANCE a_{nom}

Table 29: optibelt VB classic V-belts

Datum length [mm]	Minimum allowance x [mm] – for tensioning	Minimum allowance y [mm] – for easy fitting											
		5	Y/6	8	Z/10, ZX/X10	A/13, AX/X13	B/17, BX/X17	20	C/22, CX/X22	25	D/32	E/40	
≤ 200	5	10	–	–	–	–	–	–	–	–	–	–	–
> 200 ≤ 250	5	10	10	–	–	–	–	–	–	–	–	–	–
> 250 ≤ 315	5	10	10	10	10	–	–	–	–	–	–	–	–
> 315 ≤ 670	10	–	–	10	10	10	10	–	–	–	–	–	–
> 670 ≤ 1000	15	–	–	10	15	15	15	–	–	–	–	–	–
> 1000 ≤ 1250	20	–	–	15	15	15	15	20	20	–	–	–	–
> 1250 ≤ 1800	25	–	–	15	20	20	20	20	25	25	–	–	–
> 1800 ≤ 2240	25	–	–	20	20	20	20	25	25	30	35	–	–
> 2240 ≤ 3000	35	–	–	–	20	20	20	25	30	30	35	40	–
> 3000 ≤ 4000	45	–	–	–	20	20	20	25	30	30	35	40	–
> 4000 ≤ 5000	55	–	–	–	20	20	20	30	30	30	35	40	–
> 5000 ≤ 6300	70	–	–	–	–	20	25	35	35	35	40	45	–
> 6300 ≤ 8000	85	–	–	–	–	20	25	40	40	40	45	50	–
> 8000 ≤ 10000	110	–	–	–	–	25	25	40	45	45	45	50	–
> 10000 ≤ 12500	135	–	–	–	–	–	30	40	45	45	50	55	–
> 12500 ≤ 15000	150	–	–	–	–	–	40	50	55	55	60	65	–
> 15000 ≤ 18000	190	–	–	–	–	–	40	50	55	55	60	65	–

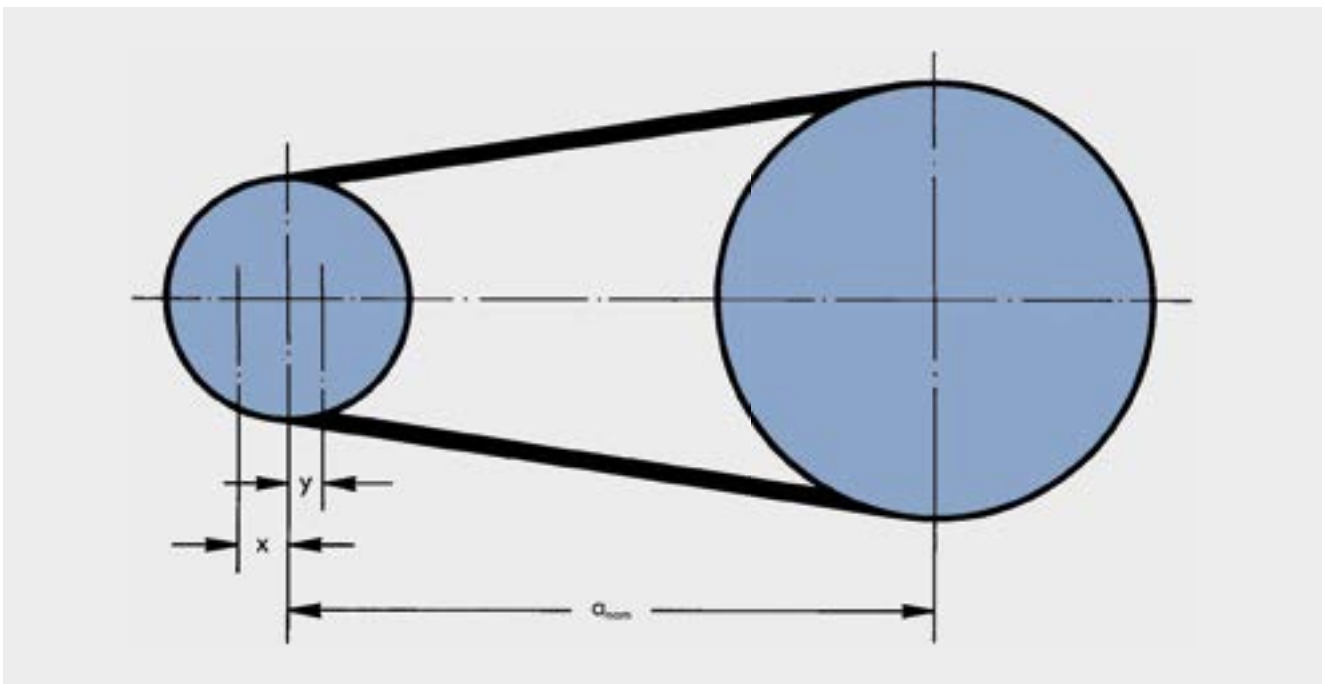

DRIVE CALCULATION

MINIMUM ALLOWANCE X/Y FOR ADJUSTING CENTRE DISTANCE a_{nom}

Table 30: optibelt KB kraftbands with wedge belts

Datum length [mm]	Outside length [mm]	Minimum allowance x [mm] – for tensioning	Minimum allowance y [mm] – for easy fitting			
			SPZ, 3V/9J	SPA, SPB, 5V/15J	8V/25J	SPC
475 ≤ 710	1206 ≤ 1803	25	35	40	–	–
> 710 ≤ 850	> 1803 ≤ 2159	25	35	40	–	–
> 850 ≤ 1180	> 2159 ≤ 2997	35	35	40	80	–
> 1180 ≤ 1600	> 2997 ≤ 4064	45	35	40	80	80
> 1600 ≤ 2000	> 4064 ≤ 5080	55	40	45	85	85
> 2000 ≤ 2500	> 5080 ≤ 6350	70	45	50	85	85
> 2500 ≤ 3150	> 6350 ≤ 8001	85	50	55	95	95
> 3150 ≤ 4000	> 8001 ≤ 10160	110	50	55	95	95
> 4000 ≤ 5000	> 10160 ≤ 12700	135	–	60	95	95
> 5000 ≤ 6000	> 12700 ≤ 15240	150	–	70	105	105
> 6000 ≤ 7100	> 15240 ≤ 18034	190	–	85	120	120

Note: For kraftbands in profiles SPZ, SPA, SPB and SPC please take into account the datum lengths.
For raw edge kraftbands the same x/y values apply.

Table 31: optibelt KB kraftbands with classic V-belts

Length [mm]	Minimum allowance x [mm] – for tensioning	Minimum allowance y [mm] – for easy fitting			
		A/HA	B/HB	C/HC	D/HD
1200 ≤ 1800	25	30	35	–	–
> 1800 ≤ 2240	25	30	35	–	–
> 2240 ≤ 3000	35	30	35	50	85
> 3000 ≤ 4000	45	30	35	50	85
> 4000 ≤ 5000	55	30	40	55	90
> 5000 ≤ 6300	70	35	45	60	90
> 6300 ≤ 8000	85	45	55	65	100
> 8000 ≤ 10000	110	45	55	65	100
> 10000 ≤ 12500	135	50	60	75	100
> 12500 ≤ 15000	150	60	70	85	110
> 15000 ≤ 18000	190	70	85	95	125

DRIVE CALCULATION

FORMULAS AND CALCULATION EXAMPLE

Drive machine

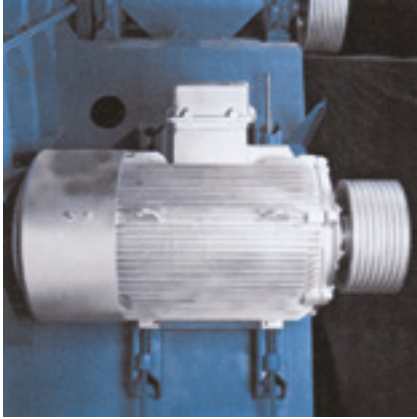

3-phase motor
 $P = 132 \text{ kW}$
 $n_1 = 1485 \text{ rpm}$
 Star delta start
 Starting torque $M_A = 0.65 M_N$

Operating conditions

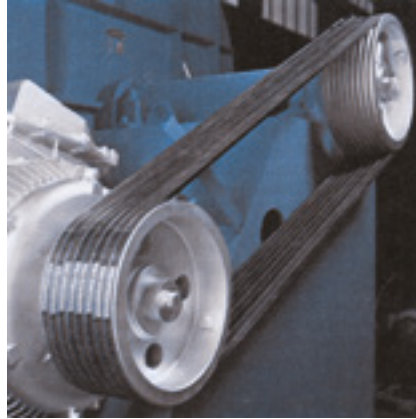

Daily operation: approx. 18 hours
 Number of starts: one per day
 Operating conditions:
 normal room temperature, no exposure
 to oil, water or dust
 Drive centre distance: between
 1300 and 1500 mm, variable
 Pulley diameter: $d_{d1} \leq 300 \text{ mm}$

Driven machine



Fan
 $P = 132 \text{ kW}$
 $n_2 = 825 \pm 15 \text{ rpm}$
 Start-up: under load
 Type of loading: continuous

Note: The calculation takes into account the standard specified according to ISO for datum diameter d_d (formerly pitch diameter d_w) and datum length L_d (formerly pitch length L_w).

Formulas

Load factor

c_2 from table 23, page 75

Design power

$$P_B = P \cdot c_2$$

Selection of belt profile

from diagram 2, page 80

Speed ratio

$$i = \frac{n_1}{n_2} = \frac{d_{d2}}{d_{d1}}$$

Datum diameter of the grooved pulley

d_{d1} selected from table 15, page 52

$$d_{d2} = d_{d1} \cdot i$$

$$d_{d1} = \frac{d_{d2}}{i}$$

Calculation example

$$c_2 = 1.3$$

$$P_B = 132 \cdot 1.3 = 171.6 \text{ kW}$$

SPB

$$i = \frac{1485}{825} = 1.8$$

$d_{d1} = 280 \text{ mm}$ selected

$$d_{d2} = 280 \text{ mm} \cdot 1.8 = 504$$

$d_{d2} = 500 \text{ mm}$ selected from table 15, page 52

DRIVE CALCULATION

FORMULAS AND CALCULATION EXAMPLE

Formulas

Verification of driven unit speed

$$i_{\text{vorh}} = \frac{d_{d2}}{d_{d1}}$$

$$n_{2 \text{ vorh}} = \frac{n_1}{i_{\text{vorh}}}$$

Drive centre distance (preliminary choice)

recommended: $a > 0.7 (d_{dg} + d_{dk})$
 $a < 2 (d_{dg} + d_{dk})$

Datum length of the V-belt

$$L_{\text{dth}} \approx 2 a + 1.57 (d_{dg} + d_{dk}) + \frac{(d_{dg} - d_{dk})^2}{4 a}$$

actual:

$$L_{\text{dth}} = 2 a \cdot \sin \frac{\beta}{2} + \frac{\pi}{2} (d_{dg} + d_{dk}) + \frac{\alpha \cdot \pi}{180^\circ} (d_{dg} - d_{dk})$$

Centre distance

Calculated from L_{dSt} and L_{dth}

$$\text{(if } L_{\text{dSt}} > L_{\text{dth}}) \quad a_{\text{nom}} \approx a + \frac{L_{\text{dSt}} - L_{\text{dth}}}{2}$$

$$\text{(if } L_{\text{dSt}} < L_{\text{dth}}) \quad a_{\text{nom}} \approx a - \frac{L_{\text{dth}} - L_{\text{dSt}}}{2}$$

actual:

$$a_{\text{nom}} = \frac{L_{\text{dSt}} - \frac{\pi}{2} (d_{dg} + d_{dk})}{4} + \sqrt{\left[\frac{L_{\text{dSt}} - \frac{\pi}{2} (d_{dg} + d_{dk})}{4} \right]^2 - \frac{(d_{dg} - d_{dk})^2}{8}}$$

Minimum allowance x/y for adjusting centre distance a_{nom}

x/y from table 28, page 82

Calculation example

$$i_{\text{vorh}} = \frac{500}{280} = \mathbf{1.79}$$

$$n_{2 \text{ vorh}} = \frac{1485}{1.79} = \mathbf{830 \text{ min}^{-1}}$$

required:
 $825 \pm 15 \text{ rpm}$
 (requirement met)

$$a = \mathbf{1400 \text{ mm}}$$
 selected

$$L_{\text{dth}} \approx 2 \cdot 1400 + 1.57 \cdot 780 + \frac{220^2}{4 \cdot 1400} \approx 4033 \text{ mm}$$

next standard length selected from page 27

$$L_{\text{dSt}} = \mathbf{4000 \text{ mm}}$$

$$a_{\text{nom}} \approx 1400 - \frac{4033 - 4000}{2} \approx \mathbf{1383.5 \text{ mm}}$$

$$x \geq \mathbf{45 \text{ mm}} / y \geq \mathbf{20 \text{ mm}}$$

Speed and flex rate of belt

$$v = \frac{d_{dk} \cdot n_k}{19100} \quad (v_{\text{max}} \approx 55 \text{ m/s})$$

$$f_b = \frac{2 \cdot 1000 \cdot v}{L_{\text{dSt}}} \quad (f_{B \text{ max}} \approx 100 \text{ s}^{-1})$$

$$v = \frac{280 \cdot 1485}{19100} = \mathbf{21.76 \text{ m/s}}$$

$$f_b = \frac{2 \cdot 1000 \cdot 21.76}{4000} = \mathbf{10.88 \text{ s}^{-1}}$$

DRIVE CALCULATION

FORMULAS AND CALCULATION EXAMPLE

Formulas

Arc of contact and correction factor

$$\frac{d_{dg} - d_{dk}}{a_{nom}}$$

β° approximate and c_1 from table 22, page 74

$$\text{actual: } \cos \frac{\beta}{2} = \frac{d_{dg} - d_{dk}}{2 a_{nom}}$$

Calculation example

$$\frac{500 - 280}{1383.5} = 0.16$$

$$\left. \begin{array}{l} \beta \approx 170^\circ \\ c_1 = 1.0 \end{array} \right\} \text{linearly interpolated}$$

Length factor

c_3 from table 24, page 76

$$c_3 = 1.02$$

Nominal power per belt

$$P_N \text{ for } \begin{cases} d_{dk} = 280 \text{ mm} \\ i = 1.79 \\ n_k = 1485 \text{ min}^{-1} \end{cases} \begin{array}{l} \text{profile SPB} \\ \text{from table 43, page 100} \end{array}$$

$$P_N = 20.63 + 1.24 = 21.87 \text{ kW}$$

Number of belts

$$z = \frac{P \cdot c_2}{P_N \cdot c_1 \cdot c_3}$$

$$z = \frac{132 \cdot 1.3}{21.87 \cdot 1.0 \cdot 1.02} = 7.69$$

suggested:

8 optibelt SK wedge belts SPB 4000 L_d S=C plus

Profile SPB:

Minimum static tension per belt

(multiply by factor 1.3 at initial installation)

$$T \approx \frac{500 \cdot (2.04 - c_1) \cdot P_B}{c_1 \cdot z \cdot v} + k \cdot v^2$$

k from diagram 8, page 138

$$T \approx \frac{500 \cdot (2.04 - 1.0) \cdot 171.6}{1.0 \cdot 8 \cdot 21.76} + 0.19 \cdot 473.5 \approx 593 \text{ N}$$

initial installation:

$$T = 593 \text{ N} \cdot 1.3 = 771 \text{ N}$$

Minimum static shaft load

(multiply by factor 1.3 at initial installation)

$$S_a \approx 2 T \cdot \sin \frac{\beta}{2} \cdot z$$

$$S_a \approx 2 \cdot 593 \cdot 0.9962 \cdot 8 \approx 9452 \text{ N}$$

initial installation:

$$S_a = 9452 \text{ N} \cdot 1.3 = 12288 \text{ N}$$

Belt deflection

$$E_a \approx \frac{E \cdot L}{100}$$

E from diagram 8, page 138

$$L = a_{nom} \cdot \sin \frac{\beta}{2}$$

$$E_a \approx \frac{2.7 \cdot 1378}{100} \approx 37 \text{ mm}$$

$$E \approx 2.7 \text{ mm}$$

$$L = 1383.5 \cdot 0.9962 = 1378 \text{ mm}$$

DRIVE CALCULATION

optibelt CAP

The drive requires:

- 8 piece(s) optibelt SK wedge belts SPC 6300 L_d S=C plus
- optibelt KS V-grooved pulley for taper bushes TB SPC 400-8
- optibelt TB taper bush 4545 (bore diameter 55-110 mm)
- optibelt KS V-grooved pulleys for taper bushes TB SPC 800-8
- optibelt TB taper bush 5050 (bore diameter 70-125 mm)



Deviations/Notes

Type of driver unit	:	electric motor	
Type of driven unit	:	fans > 7.5 kW	
Calculation power	PB:	364.00 kW	
Drive power	P:	260.00 kW	
Torque at driver pulley	M:	1399 Nm	
Driver speed	n₁:	1775 1/min	
Effective driven speed	n₂:	888 1/min	-1 1/min
Datum diameter pulley 1	d_{d1}:	400.00 mm	
Datum diameter pulley 2	d_{d2}:	800.00 mm	
Datum length	L _d :	6300 mm	
Actual centres	a:	2198.40 mm	-1.60 mm
Actual drive ratio	i:	2.00	0.1 %
Adjustment required for belt installation	y:	35.00 mm	
Adjustment required for belt tensioning	x:	70.00 mm	
Actual load factor	c₂:	1.61	
Belt speed	v:	37.17 m/s	Dynamic balancing required
Flex rate	f _B :	11.80 1/s	
Nominal power per belt	P _N :	51.84 kW	
Arc of contact factor	c ₁ :	0.99	
Belt length factor	c ₃ :	1.02	
Arc of contact on small pulley	β:	169.60 °	
Pulley face width	b ₂ :	212.50 mm	
Span length	<:	2189.30 mm	
Calculated number of belts	zth:	6.94	for raised c ₂ = 1.40
Weight of drive		276.87 kg	
Static shaft load at initial installation	Sast:	23653 N	
Static shaft load at re-tensioning	Sast:	18195 N	
Dynamic shaft load	Sadyn:	10283 N	

Tensioning methods for raised c ₂ = 1.40		Initial installation	Operating tension
		new belts	existing belts
1. OPTIKRIK II + III	static tension per V-belt:	1484 N	1142 N
2. Belt deflection with tension gauge	test load:	125 N	125 N
	deflection:	41 mm	51 mm
3. Length addition per 1000 mm belt length	:	5.7 mm	4.3 mm
4. OPTIBELT frequency tension tester	frequency:	14.3 1/s	12.6 1/s

Regarding liability concerning this drive design we refer to our Terms and Conditions.

POWER RATINGS

optibelt **RED POWER 3** PROFILE SPZ, 3V/9N, 3V/9J

NOMINAL POWER RATING P_N [kW] FOR $\beta = 180^\circ$ AND $L_d = 1600$ mm

Table 32

Pulleys	v [m/s]	n_k [min ⁻¹]	Datum diameter of small pulley d_{jk} [mm]														Additional power [kW] per belt for speed ratio i				
			63	71	80	85	90	95	100	112	125	132	140	150	160	180	200	1.01 to 1.05	1.06 to 1.26	1.27 to 1.57	> 1.57
Statically balanced	5	700	0.72	0.96	1.22	1.37	1.51	1.66	1.80	2.14	2.50	2.70	2.92	3.19	3.47	4.02	4.56	0.01	0.06	0.09	0.11
		950	0.92	1.24	1.58	1.78	1.97	2.16	2.35	2.80	3.29	3.54	3.84	4.20	4.56	5.28	5.99	0.01	0.09	0.12	0.15
		1450	1.30	1.76	2.27	2.56	2.83	3.12	3.40	4.06	4.75	5.14	5.56	6.08	6.60	7.63	8.63	0.02	0.13	0.19	0.23
		2850	2.16	3.00	3.94	4.44	4.94	5.44	5.93	7.08	8.28	8.92	9.61	10.46	11.29	12.84	14.26	0.04	0.26	0.37	0.46
		100	0.13	0.18	0.22	0.24	0.26	0.29	0.31	0.37	0.43	0.46	0.49	0.54	0.59	0.67	0.77	0.00	0.01	0.01	0.02
		200	0.25	0.32	0.41	0.46	0.49	0.54	0.59	0.70	0.80	0.86	0.94	1.02	1.10	1.28	1.45	0.00	0.02	0.03	0.03
		300	0.36	0.46	0.58	0.65	0.71	0.78	0.84	1.00	1.16	1.25	1.36	1.49	1.61	1.86	2.11	0.00	0.03	0.04	0.05
		400	0.46	0.59	0.74	0.83	0.92	1.01	1.09	1.30	1.51	1.63	1.76	1.93	2.09	2.42	2.75	0.01	0.04	0.05	0.06
		500	0.54	0.72	0.91	1.02	1.12	1.22	1.33	1.58	1.85	1.99	2.16	2.36	2.56	2.96	3.36	0.01	0.05	0.07	0.08
		600	0.64	0.84	1.07	1.19	1.32	1.44	1.56	1.86	2.18	2.35	2.54	2.78	3.02	3.49	3.96	0.01	0.06	0.08	0.10
		700	0.72	0.96	1.22	1.37	1.51	1.66	1.80	2.14	2.50	2.70	2.92	3.19	3.47	4.02	4.56	0.01	0.06	0.09	0.11
		800	0.80	1.07	1.37	1.54	1.69	1.86	2.02	2.40	2.82	3.04	3.29	3.60	3.91	4.52	5.14	0.01	0.07	0.11	0.13
		900	0.89	1.19	1.51	1.69	1.88	2.06	2.24	2.66	3.13	3.37	3.66	4.01	4.34	5.03	5.70	0.01	0.08	0.12	0.15
		1000	0.96	1.30	1.66	1.86	2.06	2.26	2.46	2.93	3.43	3.71	4.02	4.39	4.78	5.52	6.26	0.01	0.09	0.13	0.16
		1100	1.04	1.40	1.80	2.02	2.23	2.46	2.68	3.19	3.74	4.03	4.37	4.79	5.20	6.01	6.80	0.02	0.10	0.14	0.18
		1200	1.12	1.50	1.93	2.17	2.41	2.65	2.88	3.44	4.03	4.36	4.72	5.16	5.60	6.48	7.34	0.02	0.11	0.16	0.19
		1300	1.19	1.61	2.08	2.33	2.58	2.83	3.08	3.68	4.33	4.67	5.05	5.53	6.01	6.95	7.86	0.02	0.12	0.17	0.21
		1400	1.26	1.72	2.21	2.48	2.75	3.02	3.29	3.94	4.62	4.98	5.39	5.90	6.41	7.40	8.38	0.02	0.13	0.18	0.23
		1500	1.33	1.81	2.34	2.63	2.92	3.20	3.49	4.18	4.90	5.28	5.72	6.26	6.80	7.85	8.88	0.02	0.14	0.20	0.24
		1600	1.40	1.91	2.47	2.77	3.08	3.38	3.70	4.42	5.17	5.58	6.05	6.62	7.19	8.29	9.36	0.02	0.15	0.21	0.26
		1700	1.48	2.00	2.59	2.93	3.24	3.56	3.89	4.64	5.45	5.88	6.37	6.97	7.56	8.71	9.84	0.02	0.16	0.22	0.27
		1800	1.54	2.10	2.72	3.06	3.41	3.74	4.08	4.87	5.72	6.17	6.68	7.31	7.93	9.13	10.30	0.03	0.17	0.24	0.29
		1900	1.61	2.20	2.84	3.20	3.56	3.91	4.27	5.10	5.99	6.46	6.98	7.64	8.29	9.54	10.75	0.03	0.18	0.25	0.31
		2000	1.67	2.28	2.96	3.35	3.72	4.09	4.45	5.33	6.25	6.74	7.30	7.97	8.64	9.94	11.18	0.03	0.19	0.26	0.32
		2100	1.73	2.38	3.08	3.48	3.86	4.26	4.64	5.54	6.50	7.02	7.58	8.29	8.99	10.32	11.60	0.03	0.19	0.28	0.34
		2200	1.79	2.46	3.20	3.61	4.02	4.42	4.82	5.76	6.76	7.28	7.88	8.60	9.32	10.69	12.01	0.03	0.20	0.29	0.35
		2300	1.85	2.56	3.32	3.74	4.16	4.58	4.99	5.98	7.01	7.55	8.16	8.92	9.65	11.06	12.40	0.03	0.21	0.30	0.37
		2400	1.91	2.64	3.44	3.88	4.31	4.74	5.17	6.18	7.25	7.81	8.44	9.22	9.97	11.41	12.77	0.03	0.22	0.32	0.39
		2500	1.97	2.72	3.55	4.01	4.45	4.91	5.34	6.38	7.49	8.06	8.71	9.50	10.27	11.75	13.13	0.04	0.23	0.33	0.40
		2600	2.03	2.81	3.66	4.13	4.60	5.06	5.52	6.59	7.72	8.32	8.98	9.79	10.58	12.08	13.48	0.04	0.24	0.34	0.42
		2700	2.09	2.88	3.77	4.26	4.74	5.21	5.68	6.79	7.94	8.56	9.24	10.07	10.87	12.40	13.80	0.04	0.25	0.35	0.44
		2800	2.14	2.96	3.88	4.38	4.87	5.36	5.84	6.98	8.17	8.80	9.49	10.33	11.15	12.70	14.11	0.04	0.26	0.37	0.45
		2900	2.20	3.05	3.98	4.50	5.00	5.51	6.01	7.18	8.39	9.02	9.73	10.60	11.42	12.98	14.40	0.04	0.27	0.38	0.47
		3000	2.24	3.12	4.09	4.62	5.14	5.65	6.17	7.36	8.60	9.25	9.97	10.85	11.69	13.26	14.68	0.04	0.28	0.39	0.48
		3100	2.29	3.19	4.19	4.73	5.27	5.80	6.32	7.54	8.81	9.47	10.20	11.09	11.94	13.52	14.93	0.04	0.29	0.41	0.50
		3200	2.34	3.28	4.30	4.85	5.40	5.94	6.47	7.72	9.01	9.68	10.43	11.33	12.18	13.76	15.17	0.05	0.30	0.42	0.52
		3300	2.39	3.35	4.39	4.96	5.52	6.07	6.62	7.90	9.20	9.89	10.64	11.56	12.42	14.00	15.37	0.05	0.31	0.43	0.53
		3400	2.44	3.42	4.49	5.06	5.64	6.20	6.77	8.06	9.40	10.09	10.86	11.77	12.64	14.22	15.58	0.05	0.31	0.45	0.55
		3500	2.48	3.48	4.58	5.17	5.76	6.34	6.90	8.22	9.59	10.28	11.05	11.98	12.84	14.41	15.74	0.05	0.32	0.46	0.56
		3600	2.53	3.55	4.67	5.28	5.88	6.47	7.04	8.39	9.77	10.48	11.26	12.18	13.04	14.60	15.90	0.05	0.33	0.47	0.58
3700	2.58	3.62	4.76	5.39	5.99	6.59	7.18	8.54	9.94	10.66	11.44	12.36	13.22	14.77	16.03	0.05	0.34	0.49	0.60		
3800	2.62	3.68	4.85	5.48	6.11	6.72	7.31	8.69	10.10	10.82	11.62	12.54	13.40	14.92	16.14	0.05	0.35	0.50	0.61		
3900	2.66	3.76	4.94	5.58	6.22	6.84	7.44	8.84	10.27	10.99	11.78	12.71	13.57	15.06	16.22	0.06	0.36	0.51	0.63		
4000	2.70	3.82	5.03	5.68	6.32	6.95	7.56	8.99	10.42	11.15	11.94	12.86	13.72	15.18	16.28	0.06	0.37	0.53	0.64		
4100	2.75	3.88	5.11	5.77	6.42	7.07	7.69	9.12	10.57	11.30	12.10	13.01	13.85	15.28	16.32	0.06	0.38	0.54	0.66		
4200	2.78	3.94	5.18	5.87	6.53	7.18	7.80	9.25	10.72	11.45	12.24	13.15	13.98	15.36	16.33	0.06	0.39	0.55	0.68		
4300	2.82	4.00	5.27	5.95	6.62	7.28	7.92	9.38	10.85	11.58	12.37	13.27	14.09	15.42	16.32	0.06	0.40	0.57	0.69		
4400	2.86	4.04	5.34	6.04	6.72	7.38	8.03	9.50	10.98	11.71	12.49	13.39	14.18	15.47	16.28	0.06	0.41	0.58	0.71		
4500	2.89	4.10	5.41	6.12	6.82	7.49	8.14	9.62	11.10	11.83	12.61	13.49	14.27	15.49	16.21	0.06	0.42	0.59	0.73		
4600	2.93	4.15	5.50	6.20	6.90	7.58	8.24	9.73	11.21	11.94	12.71	13.58	14.34	15.49	16.13	0.07	0.43	0.60	0.74		
4700	2.96	4.21	5.56	6.29	7.00	7.68	8.34	9.84	11.32	12.05	12.80	13.66	14.40	15.48	16.01	0.07	0.44	0.62	0.76		
4800	2.99	4.26	5.63	6.36	7.08	7.76	8.44	9.95	11.42	12.14	12.89	13.73	14.44	15.44	15.86	0.07	0.44	0.63	0.77		
4900	3.02	4.31	5.70	6.43	7.15	7.85	8.53	10.04	11.51	12.23	12.97	13.79	14.46	15.38	15.68	0.07	0.45	0.64	0.79		
5000	3.05	4.36	5.76	6.50	7.24	7.93	8.62	10.14	11.60	12.30	13.03	13.82	14.47	15.31	15.48	0.07	0.46	0.66	0.81		
5100	3.08	4.40	5.82	6.58	7.31	8.02	8.70	10.22	11.68	12.37	13.09	13.85	14.47	15.22	15.25	0.07	0.47	0.67	0.82		
5200	3.11	4.44	5.88	6.64	7.38	8.09	8.77	10.30	11.75	12.43	13.13	13.87	14.45	15.10	14.99	0.07	0.48	0.68	0.84		
5300	3.13	4.49	5.94	6.71	7.45	8.16	8.86	10.37	11.81	12.48	13.16	13.87	14.41	14.95		0.08	0.49	0.70	0.85		
5400	3.16	4.52	5.99	6.77	7.51	8.23	8.92	10.44	11.87	12.53	13.19	13.86	14.36	14.78		0.08	0.50	0.71	0.87		
5500	3.18	4.56	6.04	6.83	7.57	8.29	8.99	10.50	11.92	12.56	13.20	13.84	14.29	14.59		0.08	0.51	0.72	0.89		
5600	3.20	4.60	6.10	6.88	7.63	8.36	9.05	10.56	11.95	12.58	13.20	13.80	14.21	14.39		0.08	0.52	0.74	0.90		
5800	3.24	4.67	6.18	6.98	7.74	8.47	9.16	10.66	12.00	12.60	13.16	13.68	13.98	13.88		0.08	0.54	0.76	0.93		
6000	3.28	4.73	6.26	7.07	7.84	8.57	9.25	10.73	12.01	12.58	13.08	13.50	13.69								

POWER RATINGS

optibelt RED POWER 3 PROFILE SPA

NOMINAL POWER RATING P_N [kW] FOR $\beta = 180^\circ$ AND $L_d = 2500$ mm

Table 33

Pulleys	v [m/s]	n_k [min ⁻¹]	Datum diameter of small pulley d_{jk} [mm]														Additional power [kW] per belt for speed ratio i				
			90	95	100	112	125	132	140	150	160	180	200	224	250	280	315	1.01 to 1.05	1.06 to 1.26	1.27 to 1.57	> 1.57
Statically balanced		700	1.61	1.85	2.08	2.64	3.24	3.56	3.94	4.39	4.84	5.74	6.64	7.69	8.82	10.10	11.59	0.02	0.15	0.21	0.26
		950	2.06	2.38	2.69	3.43	4.22	4.66	5.14	5.74	6.34	7.52	8.69	10.08	11.56	13.24	15.14	0.03	0.20	0.29	0.36
		1450	2.88	3.34	3.79	4.88	6.05	6.67	7.38	8.26	9.13	10.84	12.52	14.50	16.57	18.90	21.52	0.05	0.31	0.44	0.54
		2850	4.69	5.53	6.35	8.29	10.36	11.44	12.65	14.15	15.60	18.40	21.02	23.95	26.82	29.70	32.41	0.09	0.61	0.87	1.07
		100	0.31	0.35	0.38	0.48	0.58	0.62	0.68	0.77	0.84	0.98	1.13	1.31	1.49	1.70	1.96	0.00	0.02	0.03	0.04
		200	0.56	0.64	0.71	0.89	1.07	1.18	1.28	1.43	1.57	1.85	2.14	2.47	2.82	3.24	3.71	0.01	0.04	0.06	0.07
		300	0.79	0.90	1.01	1.26	1.54	1.68	1.85	2.06	2.27	2.68	3.08	3.58	4.09	4.69	5.39	0.01	0.06	0.09	0.11
		400	1.01	1.15	1.30	1.63	1.98	2.17	2.40	2.66	2.94	3.48	4.01	4.64	5.33	6.10	7.00	0.01	0.09	0.12	0.15
		500	1.22	1.39	1.56	1.98	2.41	2.65	2.92	3.25	3.59	4.25	4.91	5.68	6.52	7.48	8.57	0.02	0.11	0.15	0.19
		600	1.42	1.62	1.82	2.32	2.83	3.12	3.43	3.83	4.22	5.00	5.77	6.70	7.68	8.81	10.10	0.02	0.13	0.18	0.22
		700	1.61	1.85	2.08	2.64	3.24	3.56	3.94	4.39	4.84	5.74	6.64	7.69	8.82	10.10	11.59	0.02	0.15	0.21	0.26
		800	1.80	2.06	2.33	2.96	3.65	4.01	4.42	4.93	5.45	6.47	7.46	8.66	9.94	11.38	13.04	0.03	0.17	0.24	0.30
		900	1.97	2.27	2.57	3.28	4.03	4.44	4.90	5.47	6.05	7.18	8.29	9.61	11.02	12.62	14.46	0.03	0.19	0.27	0.34
		1000	2.15	2.47	2.81	3.58	4.42	4.86	5.38	6.00	6.62	7.87	9.10	10.54	12.08	13.84	15.83	0.03	0.22	0.31	0.37
		1100	2.32	2.68	3.04	3.88	4.79	5.28	5.83	6.52	7.20	8.54	9.88	11.45	13.13	15.01	17.17	0.04	0.24	0.34	0.41
		1200	2.48	2.87	3.25	4.18	5.16	5.69	6.29	7.03	7.76	9.22	10.66	12.35	14.14	16.16	18.47	0.04	0.26	0.37	0.45
		1300	2.64	3.06	3.48	4.46	5.52	6.08	6.73	7.52	8.32	9.88	11.41	13.22	15.13	17.29	19.72	0.04	0.28	0.40	0.49
		1400	2.80	3.24	3.68	4.75	5.88	6.48	7.16	8.02	8.86	10.52	12.16	14.08	16.10	18.37	20.93	0.05	0.30	0.43	0.52
		1500	2.95	3.43	3.90	5.03	6.23	6.86	7.60	8.50	9.40	11.16	12.88	14.90	17.04	19.43	22.08	0.05	0.32	0.46	0.56
		1600	3.11	3.60	4.10	5.29	6.58	7.25	8.02	8.98	9.91	11.77	13.60	15.72	17.95	20.45	23.21	0.05	0.34	0.49	0.60
		1700	3.25	3.78	4.31	5.57	6.91	7.62	8.44	9.43	10.43	12.38	14.29	16.51	18.84	21.43	24.29	0.06	0.37	0.52	0.64
		1800	3.40	3.95	4.51	5.83	7.24	7.99	8.84	9.90	10.93	12.97	14.96	17.29	19.70	22.37	25.30	0.06	0.39	0.55	0.67
		1900	3.53	4.12	4.70	6.08	7.56	8.35	9.24	10.34	11.42	13.56	15.64	18.04	20.53	23.28	26.27	0.06	0.41	0.58	0.71
		2000	3.67	4.28	4.90	6.34	7.88	8.70	9.64	10.78	11.92	14.12	16.27	18.77	21.34	24.14	27.18	0.07	0.43	0.61	0.75
		2100	3.80	4.44	5.08	6.59	8.20	9.05	10.02	11.21	12.38	14.69	16.91	19.46	22.12	24.97	28.03	0.07	0.45	0.64	0.79
		2200	3.92	4.60	5.26	6.83	8.51	9.40	10.39	11.63	12.85	15.23	17.52	20.15	22.85	25.75	28.84	0.07	0.47	0.67	0.82
		2300	4.06	4.75	5.44	7.07	8.81	9.72	10.76	12.05	13.31	15.76	18.11	20.81	23.56	26.50	29.57	0.08	0.50	0.70	0.86
		2400	4.18	4.90	5.62	7.31	9.10	10.06	11.12	12.44	13.74	16.27	18.68	21.44	24.23	27.19	30.24	0.08	0.52	0.73	0.90
		2500	4.30	5.04	5.78	7.54	9.38	10.37	11.48	12.84	14.17	16.76	19.24	22.04	24.88	27.83	30.84	0.08	0.54	0.76	0.94
		2600	4.42	5.18	5.95	7.75	9.67	10.68	11.82	13.22	14.59	17.24	19.78	22.62	25.48	28.43	31.38	0.09	0.56	0.79	0.97
		2700	4.52	5.33	6.11	7.98	9.95	10.99	12.17	13.60	15.00	17.71	20.29	23.17	26.04	28.98	31.85	0.09	0.58	0.82	1.01
		2800	4.64	5.46	6.28	8.20	10.22	11.29	12.49	13.97	15.41	18.17	20.78	23.70	26.57	29.47	32.24	0.09	0.60	0.86	1.05
		2900	4.75	5.59	6.43	8.40	10.49	11.58	12.82	14.32	15.79	18.61	21.26	24.20	27.06	29.92	32.57	0.10	0.62	0.89	1.09
		3000	4.85	5.72	6.58	8.60	10.74	11.87	13.13	14.66	16.16	19.03	21.71	24.66	27.52	30.30	32.81	0.10	0.65	0.92	1.12
		3100	4.96	5.84	6.73	8.81	10.99	12.14	13.43	15.00	16.52	19.44	22.14	25.10	27.92	30.62	32.96	0.10	0.67	0.95	1.16
3200	5.05	5.96	6.88	9.00	11.23	12.41	13.73	15.32	16.87	19.82	22.55	25.51	28.28	30.90	33.05	0.11	0.69	0.98	1.20		
3300	5.15	6.08	7.01	9.19	11.47	12.67	14.00	15.64	17.21	20.20	22.93	25.88	28.61	31.12	33.05	0.11	0.71	1.01	1.24		
3400	5.24	6.20	7.15	9.37	11.70	12.92	14.28	15.94	17.53	20.54	23.29	26.22	28.90	31.26		0.11	0.73	1.04	1.27		
3500	5.33	6.31	7.28	9.55	11.93	13.16	14.56	16.22	17.84	20.88	23.63	26.53	29.12	31.34		0.12	0.75	1.07	1.31		
3600	5.41	6.42	7.40	9.72	12.14	13.40	14.81	16.51	18.14	21.19	23.94	26.81	29.32	31.37		0.12	0.77	1.10	1.35		
3700	5.50	6.52	7.52	9.89	12.35	13.63	15.06	16.78	18.42	21.49	24.23	27.04	29.45	31.33		0.12	0.80	1.13	1.39		
3800	5.58	6.62	7.64	10.06	12.55	13.86	15.30	17.03	18.70	21.77	24.49	27.24	29.54			0.13	0.82	1.16	1.42		
3900	5.65	6.72	7.76	10.21	12.74	14.06	15.53	17.28	18.95	22.02	24.72	27.41	29.58			0.13	0.84	1.19	1.46		
4000	5.72	6.80	7.87	10.36	12.94	14.27	15.74	17.51	19.19	22.26	24.92	27.54	29.57			0.13	0.86	1.22	1.50		
4100	5.80	6.90	7.98	10.51	13.12	14.46	15.95	17.74	19.42	22.48	25.10	27.62	29.51			0.14	0.88	1.25	1.54		
4200	5.86	6.98	8.09	10.64	13.28	14.65	16.15	17.94	19.62	22.67	25.26	27.68	29.39			0.14	0.90	1.28	1.57		
4300	5.93	7.07	8.18	10.78	13.45	14.82	16.33	18.13	19.82	22.85	25.38	27.70				0.14	0.93	1.31	1.61		
4400	5.99	7.14	8.27	10.91	13.61	14.99	16.51	18.31	19.99	23.00	25.48	27.66				0.15	0.95	1.34	1.65		
4500	6.04	7.21	8.36	11.03	13.75	15.16	16.68	18.48	20.16	23.14	25.54	27.59				0.15	0.97	1.37	1.69		
4600	6.08	7.28	8.45	11.15	13.90	15.30	16.84	18.64	20.30	23.23	25.56	27.48				0.15	0.99	1.41	1.72		
4700	6.14	7.34	8.53	11.26	14.03	15.43	16.97	18.78	20.44	23.32	25.56					0.16	1.01	1.44	1.76		
4800	6.18	7.40	8.60	11.35	14.15	15.56	17.10	18.90	20.56	23.39	25.54					0.16	1.03	1.47	1.80		
4900	6.23	7.46	8.68	11.45	14.27	15.68	17.22	19.01	20.65	23.42	25.46					0.16	1.05	1.50	1.84		
5000	6.26	7.51	8.74	11.54	14.36	15.79	17.33	19.10	20.72	23.44	25.37					0.17	1.08	1.53	1.87		
5100	6.30	7.56	8.80	11.63	14.46	15.89	17.42	19.19	20.78	23.42	25.24					0.17	1.10	1.56	1.91		
5200	6.32	7.61	8.86	11.70	14.56	15.97	17.51	19.26	20.83	23.38	25.08					0.17	1.12	1.59	1.95		
5300	6.35	7.64	8.90	11.77	14.63	16.06	17.58	19.31	20.86	23.32						0.18	1.14	1.62	1.99		
5400	6.37	7.68	8.95	11.83	14.70	16.12	17.63	19.34	20.86	23.23						0.18	1.16	1.65	2.02		
5500	6.40	7.70	8.99	11.89	14.76	16.18	17.68	19.37	20.84	23.11						0.18	1.18	1.68	2.06		
5600	6.41	7.74	9.02	11.94	14.81	16.22	17.71	19.38	20.82	22.97						0.19	1.21	1.71	2.10		
5700	6.42	7.75	9.05	11.98	14.84	16.25	17.72	19.37	20.76	22.80						0.19	1.23	1.74	2.13		
5800	6.42	7.78	9.07	12.01	14.88	16.27	17.72	19.33	20.69	22.60						0.19	1.25	1.77	2.17		
5900	6.43	7.79	9.10	12.05	14.90	16.28	17.72	19.30	20.60					</							

POWER RATINGS

optibelt **RED POWER 3** PROFILE SPB, 5V/15N, 5V/15J

NOMINAL POWER RATING P_N [kW] FOR $\beta = 180^\circ$ AND $L_d = 3550$ mm

Table 34

Pulleys	v [m/s]	n_k [min ⁻¹]	Datum diameter of small pulley d_{jk} [mm]												Additional power [kW] per belt for speed ratio i					
			140	150	160	180	200	224	250	280	315	335	355	375	400	1.01 to 1.05	1.06 to 1.26	1.27 to 1.57	> 1.57	
Statically balanced		700	4.82	5.57	6.32	7.80	9.28	11.02	12.89	15.02	17.48	18.88	20.26	21.62	23.33	0.05	0.33	0.47	0.58	
		950	6.23	7.22	8.21	10.18	12.11	14.41	16.86	19.66	22.86	24.66	26.45	28.21	30.38	0.07	0.45	0.64	0.78	
		1450	8.80	10.26	11.70	14.54	17.35	20.65	24.16	28.09	32.54	35.02	37.43	39.79	42.65	0.11	0.69	0.97	1.20	
		2850	14.53	17.05	19.54	24.35	28.93	34.12	39.34	44.76	50.24	52.93	55.26			0.21	1.35	1.92	2.35	
		100	0.89	1.01	1.13	1.37	1.61	1.90	2.21	2.56	2.96	3.20	3.43	3.66	3.95	0.01	0.05	0.07	0.08	
		200	1.63	1.87	2.10	2.57	3.02	3.58	4.16	4.84	5.62	6.06	6.50	6.95	7.49	0.01	0.09	0.13	0.16	
		300	2.33	2.68	3.01	3.68	4.36	5.16	6.02	7.01	8.14	8.78	9.43	10.07	10.87	0.02	0.14	0.20	0.25	
		400	2.99	3.43	3.88	4.76	5.64	6.68	7.81	9.10	10.57	11.42	12.25	13.09	14.12	0.03	0.19	0.27	0.33	
		500	3.62	4.16	4.72	5.81	6.89	8.17	9.55	11.12	12.94	13.97	15.00	16.02	17.28	0.04	0.24	0.34	0.41	
		⑤	600	4.22	4.88	5.53	6.82	8.09	9.61	11.24	13.10	15.24	16.46	17.66	18.86	20.35	0.04	0.28	0.40	0.49
		700	4.82	5.57	6.32	7.80	9.28	11.02	12.89	15.02	17.48	18.88	20.26	21.62	23.33	0.05	0.33	0.47	0.58	
		800	5.40	6.24	7.09	8.76	10.43	12.40	14.51	16.91	19.68	21.24	22.79	24.32	26.22	0.06	0.38	0.54	0.66	
		900	5.95	6.90	7.84	9.71	11.56	13.74	16.09	18.76	21.82	23.53	25.25	26.93	29.02	0.07	0.43	0.61	0.74	
		1000	6.50	7.54	8.58	10.63	12.66	15.06	17.63	20.56	23.89	25.78	27.62	29.46	31.72	0.07	0.47	0.67	0.82	
		1100	7.03	8.17	9.30	11.53	13.74	16.36	19.14	22.31	25.92	27.95	29.94	31.91	34.33	0.08	0.52	0.74	0.91	
		1200	7.55	8.78	10.00	12.42	14.80	17.62	20.62	24.01	27.89	30.05	32.18	34.27	36.84	0.09	0.57	0.81	0.99	
		⑩	1300	8.06	9.38	10.69	13.28	15.84	18.85	22.06	25.68	29.80	32.09	34.34	36.55	39.25	0.10	0.62	0.87	1.07
		1400	8.56	9.97	11.36	14.14	16.85	20.06	23.47	27.30	31.64	34.06	36.42	38.74	41.54	0.10	0.66	0.94	1.15	
		1500	9.05	10.54	12.02	14.96	17.84	21.24	24.84	28.87	33.43	35.95	38.42	40.82	43.73	0.11	0.71	1.01	1.24	
		1600	9.52	11.10	12.67	15.77	18.82	22.39	26.17	30.41	35.16	37.78	40.33	42.80	45.79	0.12	0.76	1.08	1.32	
		1700	9.98	11.65	13.31	16.57	19.76	23.52	27.47	31.88	36.82	39.52	42.14	44.69	47.74	0.12	0.81	1.14	1.40	
		1800	10.43	12.19	13.92	17.34	20.69	24.61	28.73	33.31	38.40	41.18	43.87	46.45	49.54	0.13	0.85	1.21	1.48	
		1900	10.87	12.71	14.53	18.11	21.60	25.67	29.95	34.68	39.91	42.77	45.49	48.12	51.22	0.14	0.90	1.28	1.57	
		2000	11.30	13.22	15.12	18.84	22.48	26.70	31.13	36.00	41.36	44.26	47.02	49.66	52.74	0.15	0.95	1.34	1.65	
		⑮	2100	11.72	13.73	15.70	19.56	23.33	27.71	32.26	37.26	42.72	45.66	48.44	51.06	54.12	0.15	0.99	1.41	1.73
		2200	12.13	14.21	16.26	20.27	24.16	28.68	33.36	38.47	44.02	46.97	49.74	52.36	55.36	0.16	1.04	1.48	1.81	
		2300	12.53	14.69	16.80	20.95	24.97	29.60	34.40	39.61	45.22	48.17	50.94	53.51	56.41	0.17	1.09	1.55	1.90	
		2400	12.92	15.14	17.34	21.61	25.75	30.52	35.41	40.70	46.33	49.28	52.01	54.52	57.31	0.18	1.14	1.61	1.98	
		2500	13.30	15.59	17.86	22.26	26.51	31.38	36.37	41.72	47.36	50.28	52.97	55.39	58.04	0.18	1.18	1.68	2.06	
		2600	13.67	16.03	18.35	22.88	27.23	32.21	37.27	42.67	48.31	51.18	53.78	56.11	58.60	0.19	1.23	1.75	2.14	
		2700	14.02	16.45	18.84	23.48	27.94	33.00	38.14	43.56	49.15	51.97	54.48	56.68		0.20	1.28	1.82	2.23	
		2800	14.36	16.86	19.31	24.06	28.61	33.76	38.94	44.38	49.91	52.63	55.03	57.08		0.21	1.33	1.88	2.31	
		2900	14.69	17.26	19.76	24.62	29.24	34.48	39.71	45.13	50.56	53.18	55.45			0.21	1.37	1.95	2.39	
		3000	15.01	17.63	20.20	25.15	29.86	35.15	40.40	45.80	51.11	53.62				0.22	1.42	2.02	2.47	
		3100	15.31	18.00	20.62	25.67	30.44	35.78	41.05	46.40	51.55	53.92				0.23	1.47	2.08	2.56	
		3200	15.61	18.35	21.02	26.16	31.00	36.38	41.65	46.92	51.89					0.23	1.52	2.15	2.64	
		3300	15.89	18.68	21.41	26.63	31.52	36.94	42.18	47.36	52.10					0.24	1.56	2.22	2.72	
		3400	16.16	19.01	21.78	27.07	32.02	37.44	42.66	47.72						0.25	1.61	2.29	2.80	
		3500	16.42	19.32	22.13	27.49	32.47	37.91	43.07	48.00						0.26	1.66	2.35	2.89	
		3600	16.67	19.61	22.46	27.89	32.90	38.33	43.43	48.18						0.26	1.71	2.42	2.97	
		3700	16.90	19.88	22.78	28.25	33.29	38.70	43.72	48.29						0.27	1.75	2.49	3.05	
		3800	17.11	20.15	23.08	28.60	33.65	39.02	43.93							0.28	1.80	2.55	3.13	
		3900	17.32	20.39	23.35	28.91	33.96	39.30	44.09							0.29	1.85	2.62	3.21	
		4000	17.51	20.62	23.60	29.20	34.25	39.53	44.17							0.29	1.89	2.69	3.30	
		⑳	4100	17.69	20.82	23.84	29.46	34.50	39.70	44.20						0.30	1.94	2.76	3.38	
		4200	17.84	21.02	24.06	29.69	34.70	39.82	44.15							0.31	1.99	2.82	3.46	
		4300	18.00	21.19	24.25	29.89	34.87	39.89								0.32	2.04	2.89	3.54	
		4400	18.13	21.35	24.42	30.07	35.00	39.90								0.32	2.08	2.96	3.63	
		4500	18.24	21.49	24.58	30.22	35.10	39.86								0.33	2.13	3.03	3.71	
		4600	18.35	21.61	24.71	30.34	35.15	39.77								0.34	2.18	3.09	3.79	
4700	18.43	21.72	24.82	30.42	35.16									0.34	2.23	3.16	3.87			
4800	18.50	21.80	24.90	30.47	35.12									0.35	2.27	3.23	3.96			
4900	18.56	21.86	24.96	30.49	35.05									0.36	2.32	3.29	4.04			
5000	18.60	21.91	25.01	30.48	34.93									0.37	2.37	3.36	4.12			
5100	18.62	21.94	25.02	30.43	34.76									0.37	2.42	3.43	4.20			
5200	18.64	21.95	25.01	30.36	34.56									0.38	2.46	3.50	4.29			
5300	18.62	21.94	24.98	30.24										0.39	2.51	3.56	4.37			
5400	18.60	21.90	24.92	30.10										0.40	2.56	3.63	4.45			
④0	5500	18.55	21.84	24.84	29.92									0.40	2.61	3.70	4.53			

$v_{max} \leq 55$ m/s

$v > 42$ m/s.
Please consult our
Application Engineering
Department.

v [m/s]

Dynamically balanced (for details see DIN 2211)

Pulleys

Note: Pulley diameters shown are outside diameters for sections 5V/15N, 5V/15J.

POWER RATINGS

optibelt RED POWER 3 PROFILE SPC

NOMINAL POWER RATING P_N [kW] FOR $\beta = 180^\circ$ AND $L_d = 5600$ mm

Table 35

Pulleys	v [m/s]	n_k [min ⁻¹]	Datum diameter of small pulley d_{dk} [mm]												Additional power [kW] per belt for speed ratio i				
			224	250	280	315	335	355	375	400	450	500	560	630	710	1.01 to 1.05	1.06 to 1.26	1.27 to 1.57	> 1.57
Statically balanced		700	13.31	16.61	20.38	24.71	27.17	29.59	32.00	34.99	40.87	46.63	53.38	61.01	69.38	0.14	0.90	1.28	1.57
		950	17.08	21.41	26.33	31.97	35.14	38.28	41.38	45.19	52.66	59.86	68.16	77.33	87.06	0.19	1.22	1.73	2.13
		1450	23.68	29.83	36.76	44.57	48.90	53.14	57.26	62.28	71.77	80.51	89.90	99.23	107.51	0.29	1.86	2.65	3.25
		2850	34.84	43.91	53.33	62.76	67.33	71.27	0.57	3.67	5.20	6.38							
		50	1.34	1.62	1.96	2.33	2.54	2.76	2.96	3.23	3.76	4.28	4.91	5.63	6.44	0.01	0.06	0.09	0.11
		100	2.48	3.02	3.65	4.37	4.78	5.18	5.59	6.11	7.12	8.11	9.30	10.68	12.24	0.02	0.13	0.18	0.22
		150	3.55	4.34	5.26	6.31	6.90	7.50	8.10	8.83	10.31	11.76	13.50	15.52	17.78	0.04	0.26	0.37	0.45
		200	4.56	5.60	6.79	8.17	8.95	9.73	10.51	11.47	13.39	15.30	17.57	20.18	23.15	0.06	0.39	0.55	0.67
		250	5.53	6.82	8.28	9.98	10.94	11.90	12.85	14.05	16.40	18.74	21.53	24.73	28.36	0.07	0.45	0.64	0.78
		300	6.48	8.00	9.73	11.75	12.89	14.02	15.16	16.56	19.34	22.10	25.38	29.17	33.43	0.08	0.51	0.73	0.90
		350	7.40	9.16	11.16	13.48	14.78	16.09	17.40	19.01	22.22	25.39	29.16	33.50	38.38	0.09	0.58	0.82	1.01
		400	8.30	10.28	12.54	15.17	16.64	18.12	19.60	21.42	25.04	28.62	32.86	37.73	43.20	0.10	0.64	0.91	1.12
		450	9.18	11.39	13.91	16.82	18.48	20.12	21.76	23.78	27.80	31.78	36.48	41.87	47.90	0.11	0.71	1.00	1.23
		500	10.03	12.47	15.25	18.46	20.27	22.08	23.88	26.11	30.53	34.87	40.01	45.90	52.46	0.12	0.77	1.10	1.34
		550	10.87	13.54	16.56	20.06	22.04	24.01	25.97	28.39	33.19	37.91	43.48	49.84	56.90	0.13	0.84	1.19	1.45
		600	11.70	14.58	17.86	21.64	23.77	25.90	28.01	30.64	35.80	40.88	46.86	53.66	61.21	0.14	0.90	1.28	1.57
		650	12.52	15.60	19.13	23.18	25.49	27.77	30.02	32.83	38.36	43.79	50.16	57.38	65.38	0.15	0.96	1.37	1.68
		700	13.31	16.61	20.38	24.71	27.17	29.59	32.00	34.99	40.87	46.63	53.38	61.01	69.38	0.16	1.03	1.46	1.79
		750	14.09	17.60	21.60	26.21	28.81	31.39	33.95	37.12	43.33	49.42	56.51	64.51	73.25	0.17	1.09	1.55	1.90
		800	14.86	18.58	22.81	27.68	30.43	33.16	35.86	39.19	45.74	52.13	59.56	67.90	76.96	0.18	1.16	1.64	2.01
		850	15.61	19.54	24.01	29.14	32.03	34.90	37.73	41.23	48.11	54.78	62.52	71.16	80.50	0.19	1.22	1.73	2.13
		900	16.36	20.48	25.18	30.56	33.60	36.60	39.58	43.24	50.40	57.36	65.39	74.30	83.87	0.20	1.29	1.83	2.24
		950	17.08	21.41	26.33	31.97	35.14	38.28	41.38	45.19	52.66	59.86	68.16	77.33	87.06	0.21	1.35	1.92	2.35
		1000	17.80	22.32	27.46	33.35	36.65	39.91	43.14	47.11	54.84	62.29	70.84	80.20	90.00	0.22	1.41	2.01	2.46
		1050	18.49	23.22	28.57	34.69	38.14	41.52	44.87	48.98	56.98	64.66	73.40	82.94	92.88	0.23	1.48	2.10	2.57
		1100	19.19	24.10	29.66	36.02	39.59	43.10	46.56	50.81	59.05	66.92	75.86	85.54	95.48	0.24	1.54	2.19	2.69
		1150	19.87	24.97	30.74	37.32	41.00	44.64	48.22	52.60	61.07	69.13	78.23	87.98	97.88	0.25	1.61	2.28	2.80
		1200	20.53	25.81	31.79	38.60	42.41	46.14	49.82	54.32	63.01	71.24	80.47	90.28	100.08	0.26	1.67	2.37	2.91
		1250	21.18	26.65	32.83	39.85	43.76	47.62	51.40	56.02	64.90	73.27	82.61	92.41	102.04	0.27	1.74	2.46	3.02
		1300	21.83	27.47	33.84	41.06	45.10	49.06	52.93	57.66	66.72	75.23	84.62	94.37	103.78	0.28	1.80	2.56	3.13
		1350	22.45	28.27	34.84	42.26	46.40	50.45	54.42	59.24	68.47	77.08	86.51	96.17	105.26	0.29	1.86	2.65	3.25
		1400	23.06	29.06	35.81	43.43	47.66	51.82	55.86	60.79	70.16	78.84	88.27	97.79	106.51	0.30	1.93	2.74	3.36
		1450	23.68	29.83	36.76	44.57	48.90	53.14	57.26	62.28	71.77	80.51	89.90	99.23	107.51	0.31	1.99	2.83	3.47
		1500	24.26	30.59	37.68	45.68	50.10	54.42	58.62	63.71	73.31	82.08	91.40	100.49	0.32	2.06	2.92	3.58	
		1550	24.84	31.32	38.59	46.76	51.28	55.67	59.94	65.10	74.77	83.54	92.77	101.54	0.33	2.12	3.01	3.69	
		1600	25.40	32.05	39.48	47.81	52.40	56.87	61.20	66.42	76.16	84.92	94.00	102.41	0.34	2.19	3.10	3.80	
		1650	25.96	32.75	40.34	48.84	53.51	58.03	62.42	67.69	77.47	86.18	95.06	103.08	0.35	2.25	3.19	3.92	
		1700	26.50	33.43	41.18	49.82	54.56	59.16	63.59	68.90	78.71	87.34	96.00	0.36	2.31	3.29	4.03		
		1750	27.01	34.10	42.00	50.78	55.60	60.24	64.72	70.06	79.85	88.38	96.77	0.37	2.38	3.38	4.14		
		1800	27.53	34.76	42.79	51.71	56.58	61.27	65.78	71.15	80.92	89.32	97.39	0.38	2.44	3.47	4.25		
1850	28.02	35.40	43.56	52.61	57.53	62.27	66.79	72.17	81.90	90.13	97.85	0.39	2.51	3.56	4.36				
1900	28.51	36.01	44.30	53.47	58.44	63.20	67.76	73.14	82.79	90.83	0.40	2.57	3.65	4.48					
1950	28.98	36.61	45.02	54.30	59.32	64.10	68.68	74.04	83.58	91.40	0.41	2.64	3.74	4.59					
2000	29.44	37.19	45.73	55.09	60.14	64.96	69.53	74.88	84.29	91.85	0.42	2.70	3.83	4.70					
2050	29.88	37.75	46.39	55.86	60.94	65.76	70.32	75.65	84.90	92.17	0.43	2.77	3.92	4.81					
2100	30.30	38.29	47.04	56.58	61.68	66.52	71.06	76.34	85.43	92.38	0.44	2.83	4.02	4.92					
2150	30.72	38.81	47.66	57.26	62.39	67.21	71.75	76.97	85.85	0.45	2.89	4.11	5.04						
2200	31.12	39.31	48.25	57.92	63.05	67.87	72.37	77.53	86.16	0.46	2.96	4.20	5.15						
2250	31.50	39.79	48.82	58.54	63.66	68.47	72.94	78.01	86.38	0.47	3.02	4.29	5.26						
2300	31.86	40.26	49.36	59.11	64.24	69.02	73.44	78.43	86.50	0.48	3.09	4.38	5.37						
2350	32.21	40.70	49.87	59.65	64.76	69.52	73.87	78.76	0.49	3.15	4.47	5.48							
2400	32.54	41.12	50.35	60.14	65.24	69.95	74.24	79.02	0.50	3.22	4.56	5.60							
2450	32.87	41.52	50.80	60.61	65.68	70.33	74.56	79.20	0.51	3.28	4.66	5.71							
2500	33.17	41.89	51.23	61.02	66.06	70.66	74.80	79.30	0.52	3.34	4.75	5.82							
2550	33.46	42.25	51.61	61.40	66.40	70.93	74.98	79.32	0.53	3.41	4.84	5.93							
2600	33.73	42.59	51.98	61.74	66.68	71.14	75.08	79.26	0.54	3.47	4.93	6.04							
2650	33.98	42.90	52.31	62.03	66.91	71.29	75.12	0.55	3.54	5.02	6.16								
2700	34.22	43.19	52.62	62.28	67.10	71.38	75.08	0.56	3.60	5.11	6.27								
2750	34.44	43.45	52.88	62.48	67.24	71.40	74.98	0.57	3.67	5.20	6.38								
2800	34.64	43.69	53.12	62.64	67.31	71.36	74.80	0.58	3.73	5.29	6.49								
2850	34.84	43.91	53.33	62.76	67.33	71.27	0.59	3.79	5.39	6.60									
2900	35.00	44.10	53.51	62.83	67.30	71.11	0.60	3.86	5.48	6.71									
2950	35.15	44.28	53.64	62.86	67.21	70.88	0.61	3.92	5.57	6.83									
3000	35.28	44.42	53.75	62.83	67.07	0.62	3.99	5.66	6.94										
3050	35.40	44.54	53.82	62.76	66.88	0.63	4.05	5.75	7.05										
3100	35.50	44.64	53.86	62.64	66.61	0.64	4.12	5.84	7.16										
3150	35.57	44.70	53.86	62.46	0.65	4.18	5.93	7.27											
3200	35.63	44.75	53.82	62.24	0.66	4.24	6.02	7.39											
3250	35.66	44.77	53.75	61.97	0.67	4.31	6.12	7.50											
3300	35.68	44.76	53.64	61.66	0.68	4.37	6.21	7.61											
3350	35.68	44.72	53.50	0.69	4.44	6.30	7.72												
3400	35.65	44.65	53.32	0.70	4.50	6.39	7.83												
3450	35.62	44.57	53.10																
3500	35.56	44.45	52.84																

$v_{max} \leq 55$ m/s

$v > 42$ m/s.
Please consult our
Application Engineering
Department.

v [m/s]

Dynamically balanced (for details see DIN 2211)

Pulleys

POWER RATINGS

optibelt **RED POWER 3** PROFILE 8V/25N, 8V/25J

NOMINAL POWER RATING P_N [kW] FOR $\beta = 180^\circ$ AND 8V 2500/6350 mm L_d

Table 36

Pulleys	v [m/s]	n_k [min ⁻¹]	Outside diameter of small pulley d_{ok} [mm]												Additional power [kW] per belt for speed ratio i					
			335	355	375	425	450	475	500	530	560	600	630	710	800	1.01 to 1.05	1.06 to 1.26	1.27 to 1.57	> 1.57	
Statically balanced	5	700	33.85	37.57	41.26	50.27	54.67	59.00	63.26	68.28	73.18	79.54	84.17	95.89	107.94	0.28	1.83	2.60	3.18	
		950	42.72	47.41	52.01	63.12	68.45	73.63	78.65	84.44	89.99	96.97	101.89	113.58	124.01	0.38	2.48	3.52	4.32	
		1450	55.34	61.15	66.68	79.30	84.90	90.01	94.58	99.36	103.31	107.21	109.06			0.59	3.79	5.38	6.60	
		50	3.36	3.70	4.03	4.85	5.27	5.68	6.08	6.56	7.06	7.70	8.18	9.46	10.88	0.02	0.13	0.19	0.23	
		100	6.28	6.91	7.55	9.12	9.91	10.69	11.47	12.41	13.33	14.57	15.49	17.94	20.66	0.04	0.26	0.37	0.45	
		150	9.00	9.94	10.86	13.18	14.32	15.46	16.60	17.95	19.31	21.11	22.45	26.00	29.95	0.06	0.39	0.56	0.68	
		200	11.62	12.83	14.04	17.06	18.55	20.04	21.53	23.30	25.07	27.40	29.15	33.76	38.88	0.08	0.52	0.74	0.91	
		250	14.14	15.64	17.12	20.82	22.66	24.48	26.30	28.48	30.64	33.49	35.62	41.24	47.47	0.10	0.65	0.93	1.14	
		10	300	16.57	18.35	20.11	24.48	26.64	28.80	30.94	33.49	36.02	39.38	41.88	48.47	55.73	0.12	0.78	1.11	1.36
			350	18.95	20.99	23.00	28.03	30.52	32.99	35.44	38.36	41.27	45.10	47.95	55.43	63.65	0.14	0.91	1.30	1.59
			400	21.25	23.56	25.84	31.49	34.28	37.06	39.82	43.09	46.34	50.63	53.81	62.12	71.22	0.16	1.05	1.48	1.82
			450	23.50	26.05	28.58	34.85	37.94	41.02	44.06	47.68	51.25	55.97	59.45	68.54	78.42	0.18	1.18	1.67	2.05
			500	25.68	28.49	31.26	38.12	41.51	44.86	48.17	52.12	55.99	61.10	64.87	74.68	85.22	0.20	1.31	1.86	2.27
		15	550	27.82	30.85	33.88	41.30	44.96	48.58	52.15	56.39	60.58	66.05	70.07	80.48	91.61	0.22	1.44	2.04	2.50
			600	29.88	33.16	36.41	44.39	48.31	52.18	56.00	60.52	64.97	70.76	75.02	85.98	97.54	0.24	1.57	2.23	2.73
			650	31.90	35.40	38.87	47.38	51.55	55.66	59.71	64.49	69.17	75.28	79.73	91.12	103.00	0.26	1.70	2.41	2.96
			700	33.85	37.57	41.26	50.27	54.67	59.00	63.26	68.28	73.18	79.54	84.17	95.89	107.94	0.28	1.83	2.60	3.18
			750	35.75	39.68	43.56	53.05	57.67	62.22	66.67	71.89	76.99	83.57	88.33	100.28	112.34	0.30	1.96	2.78	3.41
		20	800	37.58	41.72	45.79	55.74	60.56	65.29	69.91	75.32	80.58	87.34	92.20	104.27	116.20	0.32	2.09	2.97	3.64
			850	39.36	43.69	47.95	58.31	63.32	68.22	73.00	78.56	83.95	90.83	95.75	107.83	119.44	0.34	2.22	3.15	3.87
			900	41.08	45.59	50.03	60.77	65.95	71.00	75.91	81.61	87.10	94.04	98.99	110.94	122.05	0.36	2.35	3.34	4.09
			950	42.72	47.41	52.01	63.12	68.45	73.63	78.65	84.44	89.99	96.97	101.89	113.58	124.01	0.38	2.48	3.52	4.32
			1000	44.30	49.16	53.92	65.35	70.81	76.09	81.19	87.06	92.63	99.59	104.45	115.72	125.27	0.40	2.61	3.71	4.55
		25	1050	45.83	50.83	55.73	67.45	73.02	78.38	83.54	89.45	95.02	101.89	106.63	117.35	125.80	0.42	2.74	3.90	4.78
			1100	47.28	52.43	57.44	69.42	75.08	80.52	85.70	91.60	97.12	103.86	108.43	118.44	125.57	0.44	2.88	4.08	5.00
			1150	48.66	53.94	59.08	71.27	76.99	82.46	87.65	93.52	98.94	105.48	109.84	118.97		0.46	3.01	4.27	5.23
			1200	49.97	55.37	60.60	72.97	78.74	84.22	89.39	95.17	100.46	106.74	110.83	118.92		0.49	3.14	4.45	5.46
			1250	51.19	56.70	62.03	74.54	80.33	85.79	90.90	96.56	101.69	107.64	111.40	118.26		0.51	3.27	4.64	5.69
		30	1300	52.36	57.96	63.36	75.96	81.74	87.16	92.18	97.69	102.60	108.14	111.52		0.53	3.40	4.82	5.91	
			1350	53.44	59.11	64.58	77.23	82.98	88.32	93.24	98.54	103.18	108.24	111.17		0.55	3.53	5.01	6.14	
			1400	54.43	60.18	65.69	78.35	84.04	89.27	94.03	99.10	103.42				0.57	3.66	5.19	6.37	
			1450	55.34	61.15	66.68	79.30	84.90	90.01	94.58	99.36	103.31				0.59	3.79	5.38	6.60	
			1500	56.18	62.02	67.57	80.09	85.58	90.52	94.88	99.31	102.84				0.61	3.92	5.57	6.82	
		35	1550	56.93	62.78	68.34	80.71	86.06	90.79	94.91						0.63	4.05	5.75	7.05	
			1600	57.58	63.46	68.98	81.17	86.34	90.84	94.64						0.65	4.18	5.94	7.28	
			1650	58.15	64.01	69.49	81.44	86.40	90.64	94.12						0.67	4.31	6.12	7.51	
			1700	58.62	64.46	69.89	81.54	86.26	90.18	93.29						0.69	4.44	6.31	7.73	
			1750	58.99	64.80	70.15	81.43	85.88	89.47	92.16						0.71	4.57	6.49	7.96	
		40	1800	59.28	65.02	70.27	81.14	85.28								0.73	4.70	6.68	8.19	
			1850	59.45	65.12	70.26	80.66	84.46								0.75	4.84	6.86	8.42	
1900	59.53		65.10	70.10	79.98	83.39								0.77	4.97	7.05	8.64			
1950	59.51		64.96	69.82	79.08	82.08								0.79	5.10	7.23	8.87			
2000	59.36		64.69	69.37	77.98	80.52								0.81	5.23	7.42	9.10			
2050	59.12		64.30	68.77										0.83	5.36	7.61	9.33			
2100	58.78		63.77	68.03										0.85	5.49	7.79	9.55			
2150	58.31		63.11	67.12										0.87	5.62	7.98	9.78			
2200	57.72		62.32	66.05										0.89	5.75	8.16	10.01			
2250	57.01		61.38	64.82										0.91	5.88	8.35	10.23			

$v_{max} \leq 55$ m/s

$v > 42$ m/s.
Please consult our
Application Engineering
Department.

40

v [m/s]

Dynamically balanced (for details see USA standard RMA/MPTA)

Pulleys

POWER RATINGS

optibelt BLUE POWER PROFILE SPB

NOMINAL POWER RATING P_N [kW] FOR $\beta = 180^\circ$ AND $L_w = 3550$ mm

Table 37

Pulleys	v [m/s]	n_k [min ⁻¹]	Pitch diameter of small pulley d_{wk} [mm]												Additional power [kW] per belt for speed ratio i			
			180	190	200	212	224	236	250	280	315	355	375	400	1.01 to 1.05	1.06 to 1.26	1.27 to 1.57	> 1.57
Dynamically balanced		700	8.72	9.93	11.12	12.54	13.97	15.39	17.04	20.54	24.57	29.09	31.33	34.09	0.09	0.60	0.85	1.04
		950	11.48	13.08	14.66	16.55	18.42	20.29	22.46	27.01	32.21	38.00	40.81	44.25	0.13	0.81	1.16	1.42
		1450	16.46	18.76	21.03	23.72	26.36	28.98	31.96	38.16	45.01	52.26	55.64	59.61	0.19	1.24	1.76	2.16
		2850	24.74	28.07	31.23	34.79	38.07	41.06	44.17	49.35	52.57	0.00	0.00	0.00	0.38	2.44	3.47	4.25
		100	1.40	1.58	1.76	1.97	2.20	2.41	2.67	3.21	3.84	4.56	4.91	5.36	0.01	0.09	0.12	0.15
		200	2.70	3.05	3.42	3.85	4.27	4.70	5.19	6.26	7.50	8.92	9.62	10.50	0.03	0.17	0.24	0.30
		300	3.96	4.49	5.03	5.66	6.29	6.93	7.67	9.24	11.07	13.16	14.20	15.48	0.04	0.26	0.36	0.45
		400	5.19	5.89	6.59	7.43	8.27	9.11	10.08	12.17	14.57	17.30	18.68	20.36	0.05	0.34	0.49	0.60
		500	6.38	7.27	8.13	9.17	10.21	11.24	12.45	15.02	17.99	21.35	23.03	25.10	0.07	0.43	0.61	0.75
		600	7.57	8.61	9.63	10.88	12.11	13.34	14.77	17.81	21.32	25.28	27.24	29.68	0.08	0.51	0.73	0.89
		700	8.72	9.93	11.12	12.54	13.97	15.39	17.04	20.54	24.57	29.09	31.33	34.09	0.09	0.60	0.85	1.04
		800	9.84	11.20	12.56	14.18	15.79	17.39	19.25	23.18	27.71	32.77	35.25	38.32	0.11	0.69	0.97	1.19
		900	10.95	12.46	13.97	15.76	17.56	19.33	21.39	25.76	30.74	36.29	39.00	42.32	0.12	0.77	1.09	1.34
		1000	12.01	13.69	15.34	17.32	19.28	21.24	23.49	28.24	33.66	39.65	42.56	46.10	0.13	0.86	1.22	1.49
		1100	13.06	14.88	16.67	18.83	20.96	23.07	25.51	30.63	36.44	42.81	45.89	49.63	0.15	0.94	1.34	1.64
		1200	14.07	16.03	17.98	20.29	22.58	24.84	27.45	32.93	39.09	45.79	49.00	52.86	0.16	1.03	1.46	1.79
		1300	15.05	17.15	19.24	21.70	24.14	26.54	29.32	35.11	41.58	48.55	51.86	55.82	0.17	1.11	1.58	1.94
		1400	16.00	18.23	20.44	23.06	25.63	28.18	31.11	37.17	43.90	51.09	54.45	58.44	0.19	1.20	1.70	2.09
		1500	16.91	19.28	21.60	24.36	27.08	29.75	32.80	39.12	46.06	53.37	56.76	60.70	0.20	1.28	1.82	2.24
		1600	17.79	20.27	22.71	25.61	28.43	31.22	34.40	40.94	48.03	55.40	58.74	62.59	0.21	1.37	1.95	2.39
		1700	18.62	21.21	23.77	26.78	29.74	32.62	35.90	42.62	50.34	57.15	60.42	64.11	0.23	1.46	2.07	2.53
		1800	19.42	22.12	24.77	27.90	30.95	33.92	37.30	44.14	51.39	58.60	61.74	65.20	0.24	1.54	2.19	2.68
		1900	20.16	22.96	25.72	28.94	32.09	35.14	38.58	45.51	52.75	59.75	62.71	65.84	0.25	1.63	2.31	2.83
		2000	20.87	23.76	26.60	29.92	33.14	36.25	39.75	46.73	53.87	60.58	63.28	66.02	0.26	1.71	2.43	2.98
		2100	21.53	24.50	27.41	30.81	34.09	37.25	40.80	47.77	54.75	61.05	63.46	65.73	0.28	1.80	2.55	3.13
		2200	22.13	25.19	28.17	31.63	34.96	38.16	41.72	48.64	55.38	61.17	63.21	64.90	0.29	1.88	2.67	3.28
		2300	22.69	25.82	28.85	32.37	35.73	38.95	42.50	49.31	55.76	60.91	62.52	63.56	0.30	1.97	2.80	3.43
		2400	23.20	26.38	29.46	33.01	36.40	39.62	43.15	49.80	55.85	60.27	61.38	61.66	0.32	2.06	2.92	3.58
		2500	23.65	26.88	30.00	33.57	36.97	40.17	43.64	50.08	55.66	59.21	59.75	59.16	0.33	2.14	3.04	3.73
		2600	24.04	27.31	30.45	34.05	37.42	40.60	43.99	50.15	55.17	59.14			0.34	2.23	3.16	3.88
		2700	24.36	27.66	30.83	34.41	37.77	40.88	44.18	49.99	54.36	58.69			0.36	2.31	3.28	4.02
		2800	24.63	27.96	31.12	34.69	38.00	41.03	44.23	49.63	53.24				0.37	2.40	3.40	4.17
		2900	24.84	28.17	31.32	34.86	38.11	41.05	44.09	49.01	51.80				0.38	2.48	3.53	4.32
		3000	24.98	28.31	31.44	34.92	38.09	40.92	43.78	48.17	49.99				0.40	2.57	3.65	4.47
		3100	25.05	28.36	31.46	34.87	37.94	40.64	43.29	47.91					0.41	2.66	3.77	4.62
		3200	25.05	28.34	31.39	34.72	37.66	40.19	42.62	47.42					0.42	2.74	3.89	4.77
		3300	24.98	28.22	31.22	34.44	37.24	39.59	41.76	47.13					0.44	2.83	4.01	4.92
		3400	24.84	28.03	30.94	34.03	36.68	38.84	40.70	46.70					0.45	2.91	4.13	5.07
		3500	24.61	27.75	30.56	33.52	35.97	37.90	39.44						0.46	3.00	4.26	5.22
		3600	24.30	27.37	30.09	32.87	35.11	37.78	39.42						0.48	3.08	4.38	5.37
		3700	23.93	26.89	29.48	32.09	34.10	37.26	38.74						0.49	3.17	4.50	5.52
		3800	23.46	26.32	28.78	31.18	32.93	36.73	38.06						0.50	3.26	4.62	5.66
		3900	22.92	25.65	27.96	30.13	31.60	36.21							0.52	3.34	4.74	5.81
		4000	22.27	24.88	27.01	28.92	30.10	35.68							0.53	3.43	4.86	5.96
		4100	21.56	24.00	25.94	28.62	30.16	35.16							0.54	3.51	4.99	6.11
		4200	20.73	23.02	24.75	27.83	29.29								0.56	3.60	5.11	6.26
		4300	19.82	21.92	23.44	27.05	28.43								0.57	3.68	5.23	6.41
		4400	18.82	20.72	21.99	26.26									0.58	3.77	5.35	6.56
		4500	17.71	19.39	20.41	25.48									0.60	3.85	5.47	6.71
		4600	17.22	18.63	19.66										0.61	3.94	5.59	6.86
4700	16.40	17.59	18.47										0.62	4.02	5.71	7.01		
4800	15.58	16.55											0.64	4.11	5.84	7.15		
4900	14.76	15.51											0.65	4.20	5.96	7.30		
5000	13.93	14.46											0.66	4.28	6.08	7.45		
5100	13.11												0.68	4.37	6.20	7.60		
5200	12.29												0.69	4.45	6.32	7.75		
5300	11.47												0.70	4.54	6.44	7.90		

v > 50 m/s.
Please consult our
Application Engineering
Department.

POWER RATINGS

optibelt **BLUE POWER PROFILE SPC**

NOMINAL POWER RATING P_N [kW] FOR $\beta = 180^\circ$ AND $L_w = 5600$ mm

Table 38

Pulleys	v [m/s]	n_k [min ⁻¹]	Pitch diameter of small pulley d_{wk} [mm]											Additional power [kW] per belt for speed ratio i			
			280	300	315	335	355	375	400	450	500	560	630	700	1.01 to 1.05	1.06 to 1.26	1.27 to 1.57
5	700	23.90	28.13	31.28	35.46	39.61	43.72	48.83	58.88	26.73	80.19	93.10	107.16	0.26	1.68	2.38	2.92
	950	31.12	36.65	40.75	46.19	51.53	56.83	63.32	75.98	88.10	101.89	116.82	132.16	0.35	2.27	3.23	3.96
	1450	43.06	50.67	56.25	63.52	70.56	77.36	85.54	100.66	113.99	127.37	138.96	146.27	0.54	3.47	4.93	6.04
	2850	49.11												1.06	6.82	9.68	11.87
	50	2.02	2.34	2.59	2.93	3.25	3.58	3.99	4.82	5.63	6.62	7.76	9.06	0.02	0.12	0.17	0.21
	100	3.89	4.54	5.03	5.68	6.33	6.99	7.78	9.41	11.02	12.95	15.19	17.74	0.04	0.24	0.34	0.42
	150	5.71	6.68	7.41	8.37	9.34	10.30	11.51	13.90	16.30	19.15	22.47	26.25	0.06	0.36	0.51	0.62
	200	7.49	8.78	9.74	11.02	12.29	13.57	15.15	18.33	21.48	25.26	29.62	34.61	0.07	0.48	0.68	0.83
	250	9.25	10.84	12.03	13.62	15.20	16.79	18.76	22.68	26.59	31.26	36.67	42.80	0.09	0.60	0.85	1.04
	10	300	10.98	12.87	14.29	16.18	18.07	19.95	22.30	26.98	31.63	37.17	43.58	50.83	0.11	0.72	1.02
350		12.67	14.88	16.52	18.72	20.90	23.09	25.80	31.21	36.58	42.98	50.36	58.69	0.13	0.84	1.19	1.46
400		14.35	16.86	18.73	21.21	23.70	26.18	29.26	35.38	41.45	48.68	56.99	66.35	0.15	0.96	1.36	1.67
450		16.00	18.80	20.90	23.67	26.46	29.22	32.66	39.49	46.26	54.26	63.48	73.79	0.17	1.08	1.53	1.87
500		17.63	20.72	23.03	26.11	29.18	32.21	36.01	43.53	50.95	59.74	69.79	81.00	0.19	1.20	1.70	2.08
550		19.24	22.61	25.14	28.50	31.85	35.17	39.30	47.49	55.55	65.07	75.92	87.98	0.20	1.32	1.87	2.29
600		20.82	24.49	27.22	30.86	34.48	38.08	42.55	51.37	60.06	70.27	81.86	94.67	0.22	1.44	2.04	2.50
650		22.37	26.32	29.26	33.18	37.06	40.92	45.72	55.17	64.44	75.31	87.60	101.07	0.24	1.56	2.21	2.71
700		23.90	28.29	31.28	35.46	39.61	43.72	48.83	58.88	68.73	80.19	93.10	107.16	0.26	1.68	2.38	2.92
750		25.40	29.89	33.25	37.69	42.10	46.47	51.88	62.51	72.87	84.91	98.38	112.91	0.28	1.80	2.55	3.12
15	800	26.87	31.64	35.18	39.89	44.53	49.15	54.85	66.04	76.89	89.46	103.40	118.31	0.30	1.91	2.72	3.33
	850	28.32	33.35	37.09	42.03	46.93	51.77	57.75	69.45	80.78	93.80	108.16	123.33	0.31	2.03	2.89	3.54
	900	29.74	35.01	38.95	44.13	49.27	54.33	60.58	72.77	84.52	97.96	112.63	127.96	0.33	2.15	3.06	3.75
	950	31.12	36.65	40.75	46.19	51.53	56.83	63.32	75.98	88.10	101.89	116.82	132.16	0.35	2.27	3.23	3.96
	1000	32.48	38.25	42.53	48.17	53.75	59.25	65.98	79.06	91.53	105.60	120.68	135.93	0.37	2.39	3.40	4.17
	1050	33.80	39.80	44.25	50.12	55.90	61.59	68.56	82.03	94.79	109.09	124.22	139.22	0.39	2.51	3.57	4.37
	1100	35.08	41.33	45.95	52.01	57.99	63.85	71.05	84.87	97.87	112.34	127.41	142.03	0.41	2.63	3.74	4.58
	1150	36.34	42.80	47.57	53.84	60.00	66.05	73.43	87.57	100.79	115.33	130.26	144.34	0.43	2.75	3.91	4.79
	1200	37.56	44.23	49.15	55.62	61.96	68.17	75.71	90.13	103.50	118.06	132.73	146.12	0.44	2.87	4.08	5.00
	1250	38.74	45.61	50.68	57.33	63.83	70.18	77.90	92.54	106.02	120.51	134.82	147.34	0.46	2.99	4.25	5.21
20	1300	39.87	46.96	52.16	58.98	65.63	72.11	79.98	94.81	108.35	122.68	136.50	147.99	0.48	3.11	4.42	5.42
	1350	40.98	48.24	53.58	60.56	67.35	73.96	81.94	96.92	110.45	124.56	137.76	148.04	0.50	3.23	4.59	5.62
	1400	42.04	49.48	54.95	62.08	68.99	75.71	83.80	98.87	112.34	126.13	138.59	147.48	0.52	3.35	4.76	5.83
	1450	43.06	50.67	56.25	63.52	70.56	77.36	85.54	100.66	113.99	127.37	138.96	146.27	0.54	3.47	4.93	6.04
	1500	44.03	51.81	57.50	64.88	72.03	78.92	87.15	102.27	115.42	128.30	138.88	144.41	0.56	3.59	5.10	6.25
	1550	44.95	52.89	58.67	66.18	73.40	80.36	88.63	103.71	116.61	128.88			0.57	3.71	5.27	6.46
	1600	45.85	53.91	59.79	67.40	74.70	81.70	89.99	104.96	117.53	129.12			0.59	3.83	5.44	6.67
	1650	46.68	54.88	60.84	68.53	75.89	82.92	91.22	106.02	118.20	129.00			0.61	3.95	5.61	6.87
	1700	47.46	55.79	61.82	69.58	77.00	84.04	92.32	106.89	118.62	128.49			0.63	4.07	5.78	7.08
	1750	48.20	56.63	62.73	70.55	77.99	85.04	93.25	107.56	118.75	127.62			0.65	4.19	5.95	7.29
25	1800	48.89	57.41	63.57	71.44	78.89	85.92	94.05	108.02	118.61				0.67	4.31	6.12	7.50
	1850	49.52	58.14	64.33	72.24	79.69	86.67	94.71	108.28	118.17				0.68	4.43	6.29	7.71
	1900	50.11	58.79	65.03	72.94	80.37	87.30	95.20	108.30	117.45				0.70	4.55	6.46	7.91
	1950	50.84	59.37	65.63	73.56	80.95	87.79	95.55	108.12	116.41				0.72	4.67	6.63	8.12
	2000	51.10	59.89	66.16	74.06	81.41	88.16	95.73	107.70	115.07				0.74	4.79	6.80	8.33
	2050	51.51	60.34	66.61	74.48	81.76	88.40	95.75	107.44					0.76	4.91	6.97	8.54
	2100	51.86	60.72	66.98	74.80	81.98	88.48	95.59	107.14					0.78	5.03	7.13	8.75
	2150	52.15	61.01	67.26	75.03	82.08	88.42	95.27	106.84					0.80	5.15	7.30	8.96
	2200	52.37	61.24	67.45	75.12	82.07	88.23	94.77						0.81	5.27	7.47	9.16
	2250	52.54	61.39	67.56	75.14	81.93	87.88	94.08						0.83	5.39	7.64	9.37
30	2300	52.64	61.46	67.58	75.03	81.65	87.85	93.84						0.85	5.51	7.81	9.58
	2350	52.67	61.45	67.49	74.82	81.24	87.77	93.43						0.87	5.62	7.98	9.79
	2400	52.64	61.35	67.31	74.48	80.70	87.64	93.01						0.89	5.74	8.15	10.00
	2450	52.54	61.17	67.05	74.03	80.02	87.51							0.91	5.86	8.32	10.21
	2500	52.37	60.90	66.67	73.47	79.20	87.38							0.93	5.98	8.49	10.41
	2550	52.12	60.55	66.21	73.33	78.88	87.25							0.94	6.10	8.66	10.62
	2600	51.81	60.12	65.63	73.00	78.34								0.96	6.22	8.83	10.83
	2650	51.42	59.58	64.95	72.66	77.79								0.98	6.34	9.00	11.04
	2700	50.96	58.95	64.16	72.33	77.25								1.00	6.46	9.17	11.25
	2750	50.43	58.24	63.27	72.00	76.70								1.02	6.58	9.34	11.46
35	2800	49.81	58.11	63.06	71.67	76.16								1.04	6.70	9.51	11.66
	2850	49.11	57.67	62.48	71.33	75.61								1.06	6.82	9.68	11.88
	2900	48.33	57.23	61.90	71.00	75.07								1.07	6.94	9.85	12.08
	2950	47.47	56.79	61.33										1.09	7.06	10.02	12.29
	3000	46.54	56.34	60.75										1.09	7.06	10.02	12.29
	3050	46.54	55.90	60.17										1.13	7.27	10.32	12.60
	3100	45.96	55.46											1.14	7.39	10.49	12.79
	3150	45.38	55.01											1.16	7.50	10.65	12.98
	3200	44.80	54.57											1.18	7.62	10.82	13.17
	3250	44.22															

POWER RATINGS

optibelt BLUE POWER PROFILE 5V

NOMINAL POWER RATING P_N [kW] FOR $\beta = 180^\circ$ AND $L_w = 3550$ mm

Table 39

Pulleys	v [m/s]	n_k [min ⁻¹]	Pitch diameter of small pulley d_{wk} [mm]											Additional power [kW] per belt for speed ratio i				
			180	190	200	212	224	236	250	280	315	355	375	400	1.01 to 1.05	1.06 to 1.26	1.27 to 1.57	> 1.57
Dynamically balanced		700	8.72	9.93	11.12	12.54	13.97	15.39	17.04	20.54	24.57	29.09	31.33	34.09	0.09	0.60	0.85	1.04
		950	11.48	13.08	14.66	16.55	18.42	20.29	22.46	27.01	32.21	38.00	40.81	44.25	0.13	0.81	1.16	1.42
		1450	16.46	18.76	21.03	23.72	26.36	28.98	31.96	38.16	45.01	52.26	55.64	59.61	0.19	1.24	1.76	2.16
		2850	24.74	28.07	31.23	34.79	38.07	41.06	44.17	49.35	52.57	0.00	0.00	0.00	0.38	2.44	3.47	4.25
		100	1.40	1.58	1.76	1.97	2.20	2.41	2.67	3.21	3.84	4.56	4.91	5.36	0.01	0.09	0.12	0.15
		200	2.70	3.05	3.42	3.85	4.27	4.70	5.19	6.26	7.50	8.92	9.62	10.50	0.03	0.17	0.24	0.30
		300	3.96	4.49	5.03	5.66	6.29	6.93	7.67	9.24	11.07	13.16	14.20	15.48	0.04	0.26	0.36	0.45
		400	5.19	5.89	6.59	7.43	8.27	9.11	10.08	12.17	14.57	17.30	18.68	20.36	0.05	0.34	0.49	0.60
		500	6.38	7.27	8.13	9.17	10.21	11.24	12.45	15.02	17.99	21.35	23.03	25.10	0.07	0.43	0.61	0.75
		600	7.57	8.61	9.63	10.88	12.11	13.34	14.77	17.81	21.32	25.28	27.24	29.68	0.08	0.51	0.73	0.89
		700	8.72	9.93	11.12	12.54	13.97	15.39	17.04	20.54	24.57	29.09	31.33	34.09	0.09	0.60	0.85	1.04
		800	9.84	11.20	12.56	14.18	15.79	17.39	19.25	23.18	27.71	32.77	35.25	38.32	0.11	0.69	0.97	1.19
		900	10.95	12.46	13.97	15.76	17.56	19.33	21.39	25.76	30.74	36.29	39.00	42.32	0.12	0.77	1.09	1.34
		1000	12.01	13.69	15.34	17.32	19.28	21.24	23.49	28.24	33.66	39.65	42.56	46.10	0.13	0.86	1.22	1.49
		1100	13.06	14.88	16.67	18.83	20.96	23.07	25.51	30.63	36.44	42.81	45.89	49.63	0.15	0.94	1.34	1.64
		1200	14.07	16.03	17.98	20.29	22.58	24.84	27.45	32.93	39.09	45.79	49.00	52.86	0.16	1.03	1.46	1.79
		1300	15.05	17.15	19.24	21.70	24.14	26.54	29.32	35.11	41.58	48.55	51.86	55.82	0.17	1.11	1.58	1.94
		1400	16.00	18.23	20.44	23.06	25.63	28.18	31.11	37.17	43.90	51.09	54.45	58.44	0.19	1.20	1.70	2.09
		1500	16.91	19.28	21.60	24.36	27.08	29.75	32.80	39.12	46.06	53.37	56.76	60.70	0.20	1.28	1.82	2.24
		1600	17.79	20.27	22.71	25.61	28.43	31.22	34.40	40.94	48.03	55.40	58.74	62.59	0.21	1.37	1.95	2.39
		1700	18.62	21.21	23.77	26.78	29.74	32.62	35.90	42.62	50.34	57.15	60.42	64.11	0.23	1.46	2.07	2.53
		1800	19.42	22.12	24.77	27.90	30.95	33.92	37.30	44.14	51.39	58.60	61.74	65.20	0.24	1.54	2.19	2.68
		1900	20.16	22.96	25.72	28.94	32.09	35.14	38.58	45.51	52.75	59.75	62.71	65.84	0.25	1.63	2.31	2.83
		2000	20.87	23.76	26.60	29.92	33.14	36.25	39.75	46.73	53.87	60.58	63.28	66.02	0.26	1.71	2.43	2.98
		2100	21.53	24.50	27.41	30.81	34.09	37.25	40.80	47.77	54.75	61.05	63.46	65.73	0.28	1.80	2.55	3.13
		2200	22.13	25.19	28.17	31.63	34.96	38.16	41.72	48.64	55.38	61.17	63.21	64.90	0.29	1.88	2.67	3.28
		2300	22.69	25.82	28.85	32.37	35.73	38.95	42.50	49.31	55.76	60.91	62.52	63.56	0.30	1.97	2.80	3.43
		2400	23.20	26.38	29.46	33.01	36.40	39.62	43.15	49.80	55.85	60.27	61.38	61.66	0.32	2.06	2.92	3.58
		2500	23.65	26.88	30.00	33.57	36.97	40.17	43.64	50.08	55.66	59.21	59.75	59.16	0.33	2.14	3.04	3.73
		2600	24.04	27.31	30.45	34.05	37.42	40.60	43.99	50.15	55.17	59.14			0.34	2.23	3.16	3.88
		2700	24.36	27.66	30.83	34.41	37.77	40.88	44.18	49.99	54.36	58.69			0.36	2.31	3.28	4.02
		2800	24.63	27.96	31.12	34.69	38.00	41.03	44.23	49.63	53.24				0.37	2.40	3.40	4.17
		2900	24.84	28.17	31.32	34.86	38.11	41.05	44.09	49.01	51.80				0.38	2.48	3.53	4.32
		3000	24.98	28.31	31.44	34.92	38.09	40.92	43.78	48.17	49.99				0.40	2.57	3.65	4.47
		3100	25.05	28.36	31.46	34.87	37.94	40.64	43.29	47.91					0.41	2.66	3.77	4.62
		3200	25.05	28.34	31.39	34.72	37.66	40.19	42.62	47.42					0.42	2.74	3.89	4.77
		3300	24.98	28.22	31.22	34.44	37.24	39.59	41.76	47.13					0.44	2.83	4.01	4.92
		3400	24.84	28.03	30.94	34.03	36.68	38.84	40.70	46.70					0.45	2.91	4.13	5.07
		3500	24.61	27.75	30.56	33.52	35.97	37.90	39.44						0.46	3.00	4.26	5.22
		3600	24.30	27.37	30.09	32.87	35.11	37.78	39.42						0.48	3.08	4.38	5.37
		3700	23.93	26.89	29.48	32.09	34.10	37.26	38.74						0.49	3.17	4.50	5.52
		3800	23.46	26.32	28.78	31.18	32.93	36.73	38.06						0.50	3.26	4.62	5.66
		3900	22.92	25.65	27.96	30.13	31.60	36.21							0.52	3.34	4.74	5.81
		4000	22.27	24.88	27.01	28.92	30.10	35.68							0.53	3.43	4.86	5.96
		4100	21.56	24.00	25.94	28.62	30.16	35.16							0.54	3.51	4.99	6.11
		4200	20.73	23.02	24.75	27.83	29.29								0.56	3.60	5.11	6.26
		4300	19.82	21.92	23.44	27.05	28.43								0.57	3.68	5.23	6.41
		4400	18.82	20.72	21.99	26.26									0.58	3.77	5.35	6.56
		4500	17.71	19.39	20.41	25.48									0.60	3.85	5.47	6.71
		4600	17.22	18.63	19.66										0.61	3.94	5.59	6.86
4700	16.40	17.59	18.47										0.62	4.02	5.71	7.01		
4800	15.58	16.55											0.64	4.11	5.84	7.15		
4900	14.76	15.51											0.65	4.20	5.96	7.30		
5000	13.93	14.46											0.66	4.28	6.08	7.45		
5100	13.11												0.68	4.37	6.20	7.60		
5200	12.29												0.69	4.45	6.32	7.75		
5300	11.47												0.70	4.54	6.44	7.90		

v > 50 m/s.
Please consult our
Application Engineering
Department.

POWER RATINGS

optibelt BLUE POWER PROFILE 8V

NOMINAL POWER RATING P_N [kW] FOR $\beta = 180^\circ$ AND 8V 2500/6350 mm L_w

Table 40

Pulleys	v [m/s]	n_k [min ⁻¹]	Outside diameter of small pulley d_{ok} [mm]											Additional power [kW] per belt for speed ratio i					
			355	375	400	425	450	475	500	530	560	600	630	710	800	1.01 to 1.05	1.06 to 1.26	1.27 to 1.57	> 1.57
Dynamically balanced	700	39.14	45.42	53.19	60.87	68.49	76.01	83.44	92.23	100.88	112.20	120.48	141.79	164.21	0.53	3.41	4.83	5.93	
		950	49.80	57.85	67.75	77.46	86.98	96.29	105.39	116.03	126.31	139.48	148.90	172.07	194.33	0.71	4.62	6.56	8.04
	1450	63.83	74.19	86.60	98.39	109.54	119.98	129.70	140.34	149.81	160.51	167.01			1.09	7.05	10.01	12.28	
	50	3.43	3.93	4.56	5.18	5.81	6.44	7.06	7.80	8.55	9.55	10.29	12.26	14.49	0.04	0.24	0.35	0.42	
	100	6.61	7.59	8.82	10.05	11.28	12.50	13.73	15.20	16.67	18.62	20.08	23.97	28.32	0.08	0.49	0.69	0.85	
	150	9.66	11.13	12.96	14.78	16.60	18.42	20.24	22.43	24.60	27.48	29.65	35.41	41.83	0.11	0.73	1.04	1.27	
	200	12.64	14.59	17.01	19.42	21.83	24.23	26.63	29.50	32.37	36.18	39.03	46.59	55.05	0.15	0.97	1.38	1.69	
	250	15.57	17.98	20.97	23.97	26.95	29.93	32.90	36.46	40.00	44.70	48.23	57.55	67.96	0.19	1.22	1.73	2.12	
	5	300	18.42	21.29	24.86	28.42	31.98	35.52	39.05	43.27	47.47	53.06	57.23	68.26	80.53	0.23	1.46	2.07	2.54
		350	21.22	24.54	28.69	32.80	36.92	41.01	45.08	49.97	54.81	61.25	66.04	78.71	92.74	0.26	1.70	2.42	2.96
		400	23.97	27.73	32.42	37.10	41.75	46.38	51.00	56.50	61.98	69.23	74.63	88.84	104.52	0.30	1.95	2.76	3.39
		450	26.66	30.86	36.09	41.31	46.49	51.65	56.78	62.90	68.98	77.01	82.98	98.66	115.86	0.34	2.19	3.11	3.81
		500	29.29	33.92	39.69	45.43	51.13	56.80	62.43	69.13	75.78	84.56	91.07	108.12	126.70	0.38	2.43	3.45	4.23
	10	550	31.85	36.90	43.20	49.45	55.65	61.81	67.93	75.19	82.39	91.88	98.90	117.19	137.00	0.41	2.68	3.80	4.66
		600	34.34	39.82	46.62	53.37	60.06	66.70	73.26	81.07	88.79	98.92	106.41	125.85	146.72	0.45	2.92	4.14	5.08
		650	36.78	42.66	49.95	57.18	64.34	71.43	78.44	86.76	94.96	105.71	113.62	134.06	155.81	0.49	3.16	4.49	5.50
		700	39.14	45.42	53.19	60.87	68.49	76.01	83.44	92.23	100.88	112.20	120.48	141.79	164.21	0.53	3.41	4.83	5.93
		750	41.44	48.09	56.32	64.46	72.49	80.43	88.24	97.48	106.55	118.36	126.98	149.00	171.88	0.56	3.65	5.18	6.35
	15	800	43.65	50.67	59.35	67.91	76.36	84.67	92.86	102.51	111.94	124.18	133.10	155.67	178.77	0.60	3.89	5.52	6.77
		850	45.79	53.18	62.27	71.23	80.07	88.75	97.26	107.28	117.04	129.67	138.81	161.76	184.84	0.64	4.13	5.87	7.20
		900	47.84	55.55	65.07	74.42	83.61	92.61	101.44	111.79	121.84	134.76	144.09	167.24	190.05	0.68	4.38	6.21	7.62
		950	49.80	57.85	67.75	77.46	86.98	96.29	105.39	116.03	126.31	139.48	148.90	172.07	194.33	0.71	4.62	6.56	8.04
		1000	51.67	60.03	70.29	80.35	90.17	99.76	109.10	119.98	130.45	143.77	153.26	176.22	197.65	0.75	4.86	6.90	8.47
	20	1050	53.45	62.10	72.72	83.08	93.18	103.01	112.56	123.62	134.23	147.63	157.09	179.66	199.95	0.79	5.11	7.25	8.89
		1100	55.13	64.06	75.00	85.64	96.00	106.04	115.75	126.97	137.65	151.05	160.41	182.35	201.18	0.83	5.35	7.60	9.31
		1150	56.71	65.91	77.13	88.03	98.60	108.82	118.66	129.96	140.67	153.99	163.18	184.25	201.29	0.87	5.59	7.94	9.74
		1200	58.18	67.63	79.11	90.24	101.01	111.36	121.30	132.64	143.30	156.42	165.40	185.35	200.24	0.90	5.84	8.29	10.16
		1250	59.56	69.22	80.95	92.27	103.18	113.64	123.62	134.95	145.50	158.35	166.99	185.60	197.99	0.94	6.08	8.63	10.58
	25	1300	60.80	70.67	82.61	94.12	105.14	115.65	125.64	136.88	147.28	159.74	167.99	185.28		0.98	6.32	8.98	11.01
		1350	61.94	71.99	84.13	95.75	106.85	117.39	127.33	138.43	148.60	160.58	168.34	185.10		1.02	6.57	9.32	11.43
		1400	62.94	73.16	85.46	97.19	108.32	118.83	128.69	139.59	149.45	160.85	168.01			1.05	6.81	9.67	11.85
		1450	63.83	74.19	86.60	98.39	109.54	119.98	129.70	140.34	149.81	160.51	167.01			1.09	7.05	10.01	12.28
		1500	64.58	75.05	87.57	99.40	110.49	120.82	130.35	140.66	149.67	159.56	165.28			1.13	7.30	10.36	12.70
	30	1550	65.20	75.77	88.34	100.16	111.17	121.35	130.63	140.55	149.53	159.52				1.17	7.54	10.70	13.12
		1600	65.69	76.33	88.93	100.70	111.59	121.55	130.54	139.97	149.39	159.18				1.20	7.78	11.05	13.55
		1650	66.02	76.72	89.31	100.98	111.71	121.41	130.05	138.92	149.25					1.24	8.03	11.39	13.97
		1700	66.22	76.93	89.47	101.02	111.54	120.93	129.16	137.41	149.11					1.28	8.27	11.74	14.39
		1750	66.26	76.97	89.43	100.81	111.06	120.09	127.86	135.39						1.32	8.51	12.08	14.82
	35	1800	66.16	76.83	89.17	100.34	110.26	118.87	127.58	134.59						1.35	8.76	12.43	15.24
		1850	65.90	76.50	88.68	99.60	109.16	117.29	126.88							1.39	9.00	12.77	15.66
		1900	65.46	75.98	87.96	98.56	107.72	115.32	126.19							1.43	9.24	13.12	16.09
		1950	64.86	75.26	87.00	97.26	105.94	112.95	125.50							1.47	9.49	13.46	16.51
		2000	64.11	74.35	85.81	95.65	103.81	110.17								1.50	9.73	13.81	16.93
	40	2050	63.15	73.22	84.35	95.46	103.84	109.36								1.54	9.97	14.16	17.36
		2100	62.03	71.89	82.64	94.57	102.72									1.58	10.22	14.50	17.78
		2150	60.73	70.35	80.67	93.67	101.59									1.62	10.46	14.85	18.20
		2200	59.25	68.57	78.44	92.78										1.66	10.70	15.15	18.62
		2250	59.25	68.57	78.44	91.89										1.69	10.95	15.54	19.05
	45	2300	58.12	67.23	76.39											1.73	11.19	15.87	19.47
		2350	57.19	66.12	74.88											1.77	11.43	16.22	19.89
2400		56.27	65.02	73.37											1.81	11.68	16.56	20.32	
2450		55.34	63.92												1.84	11.92	16.90	20.74	
2500		54.41	62.81												1.88	12.16	17.25	21.16	
50	2550	53.49	61.71												1.92	12.41	17.59	21.59	
	2600	52.56													1.96	12.65	17.94	22.01	
	2650	51.63													2.00	12.89	18.28	22.43	
	2700	50.71													2.03	13.14	18.62	22.85	

v > 50 m/s.
Please consult our
Application Engineering
Department.

$L_w = L_d$

POWER RATINGS

optibelt **SK PROFILE SPZ, 3V/9N, 3V/9J**

NOMINAL POWER RATING P_N [kW] FOR $\beta = 180^\circ$ AND $L_d = 1600$ mm

Table 41

Pulleys	v [m/s]	n_k [min ⁻¹]	Datum diameter of small pulley d_{dk} [mm]														Additional power [kW] per belt for speed ratio i				
			63	71	80	85	90	95	100	112	125	132	140	150	160	180	200	1.01 to 1.05	1.06 to 1.26	1.27 to 1.57	> 1.57
Statically balanced	5	700	0.50	0.68	0.88	1.00	1.11	1.22	1.33	1.60	1.88	2.03	2.20	2.42	2.63	3.05	3.47	0.01	0.06	0.09	0.11
		950	0.63	0.87	1.14	1.29	1.44	1.59	1.74	2.08	2.46	2.66	2.89	3.17	3.45	4.00	4.54	0.01	0.09	0.12	0.15
		1450	0.87	1.23	1.62	1.84	2.06	2.27	2.49	3.00	3.54	3.83	4.16	4.56	4.96	5.75	6.51	0.02	0.13	0.19	0.23
		2850	1.38	2.03	2.74	3.13	3.52	3.90	4.27	5.15	6.07	6.55	7.08	7.72	8.34	9.50	10.55	0.04	0.26	0.37	0.46
		100	0.10	0.13	0.16	0.18	0.20	0.22	0.24	0.28	0.33	0.35	0.38	0.42	0.45	0.52	0.59	0.00	0.01	0.01	0.02
		200	0.18	0.24	0.30	0.34	0.37	0.41	0.44	0.52	0.61	0.66	0.71	0.78	0.85	0.98	1.12	0.00	0.02	0.03	0.03
		300	0.25	0.33	0.43	0.48	0.53	0.58	0.63	0.75	0.88	0.95	1.03	1.13	1.23	1.42	1.62	0.00	0.03	0.04	0.05
		400	0.32	0.43	0.55	0.62	0.68	0.75	0.81	0.97	1.14	1.23	1.34	1.47	1.59	1.85	2.10	0.01	0.04	0.05	0.06
		500	0.38	0.51	0.66	0.75	0.83	0.91	0.99	1.19	1.39	1.51	1.63	1.79	1.95	2.26	2.57	0.01	0.05	0.07	0.08
		600	0.44	0.60	0.78	0.87	0.97	1.07	1.16	1.39	1.64	1.77	1.92	2.11	2.29	2.66	3.02	0.01	0.06	0.08	0.10
		700	0.50	0.68	0.88	1.00	1.11	1.22	1.33	1.60	1.88	2.03	2.20	2.42	2.63	3.05	3.47	0.01	0.06	0.09	0.11
		800	0.55	0.76	0.99	1.12	1.24	1.37	1.50	1.79	2.12	2.29	2.48	2.72	2.96	3.44	3.91	0.01	0.07	0.11	0.13
		900	0.61	0.84	1.09	1.24	1.38	1.52	1.66	1.99	2.35	2.54	2.75	3.02	3.29	3.81	4.33	0.01	0.08	0.12	0.15
		1000	0.66	0.91	1.19	1.35	1.51	1.66	1.81	2.18	2.57	2.78	3.02	3.31	3.61	4.18	4.75	0.01	0.09	0.13	0.16
		1100	0.71	0.98	1.29	1.46	1.63	1.80	1.97	2.37	2.79	3.02	3.28	3.60	3.92	4.54	5.16	0.02	0.10	0.14	0.18
		1200	0.76	1.06	1.39	1.57	1.76	1.94	2.12	2.55	3.01	3.26	3.54	3.88	4.22	4.90	5.56	0.02	0.11	0.16	0.19
		1300	0.80	1.12	1.48	1.68	1.88	2.07	2.27	2.73	3.23	3.49	3.79	4.16	4.52	5.24	5.95	0.02	0.12	0.17	0.21
		1400	0.85	1.19	1.58	1.79	2.00	2.21	2.42	2.91	3.44	3.72	4.04	4.43	4.82	5.58	6.32	0.02	0.13	0.18	0.23
		1500	0.89	1.26	1.67	1.89	2.12	2.34	2.56	3.08	3.64	3.94	4.28	4.69	5.11	5.91	6.69	0.02	0.14	0.20	0.24
		1600	0.93	1.32	1.76	2.00	2.23	2.47	2.70	3.26	3.85	4.16	4.52	4.95	5.39	6.23	7.05	0.02	0.15	0.21	0.26
1700	0.98	1.39	1.85	2.10	2.35	2.59	2.84	3.42	4.05	4.38	4.75	5.21	5.66	6.55	7.40	0.02	0.16	0.22	0.27		
1800	1.02	1.45	1.93	2.20	2.46	2.72	2.98	3.59	4.24	4.59	4.98	5.46	5.93	6.85	7.74	0.03	0.17	0.24	0.29		
1900	1.06	1.51	2.02	2.29	2.57	2.84	3.11	3.75	4.43	4.80	5.20	5.70	6.19	7.15	8.07	0.03	0.18	0.25	0.31		
2000	1.10	1.57	2.10	2.39	2.68	2.96	3.24	3.91	4.62	5.00	5.42	5.94	6.45	7.44	8.38	0.03	0.19	0.26	0.32		
2100	1.13	1.63	2.18	2.48	2.78	3.08	3.37	4.07	4.81	5.20	5.64	6.17	6.70	7.72	8.68	0.03	0.19	0.28	0.34		
2200	1.17	1.69	2.26	2.58	2.89	3.20	3.50	4.22	4.99	5.39	5.84	6.40	6.94	7.99	8.98	0.03	0.20	0.29	0.35		
2300	1.20	1.74	2.34	2.67	2.99	3.31	3.63	4.38	5.17	5.58	6.05	6.62	7.18	8.25	9.26	0.03	0.21	0.30	0.37		
2400	1.24	1.80	2.42	2.75	3.09	3.42	3.75	4.52	5.34	5.77	6.25	6.84	7.41	8.50	9.52	0.03	0.22	0.32	0.39		
2500	1.27	1.85	2.49	2.84	3.19	3.53	3.87	4.67	5.51	5.95	6.44	7.04	7.63	8.74	9.77	0.04	0.23	0.33	0.40		
2600	1.31	1.90	2.57	2.93	3.28	3.64	3.99	4.81	5.67	6.12	6.63	7.25	7.84	8.97	10.01	0.04	0.24	0.34	0.42		
2700	1.34	1.96	2.64	3.01	3.38	3.74	4.10	4.95	5.83	6.30	6.81	7.44	8.05	9.19	10.24	0.04	0.25	0.35	0.44		
2800	1.37	2.01	2.71	3.09	3.47	3.85	4.22	5.08	5.99	6.46	6.99	7.63	8.25	9.40	10.45	0.04	0.26	0.37	0.45		
2900	1.40	2.05	2.78	3.17	3.56	3.95	4.33	5.22	6.14	6.63	7.16	7.81	8.44	9.60	10.64	0.04	0.27	0.38	0.47		
3000	1.43	2.10	2.85	3.25	3.65	4.05	4.43	5.34	6.29	6.78	7.33	7.99	8.62	9.79	10.82	0.04	0.28	0.39	0.48		
3100	1.45	2.15	2.91	3.33	3.74	4.14	4.54	5.47	6.43	6.93	7.49	8.16	8.79	9.96	10.99	0.04	0.29	0.41	0.50		
3200	1.48	2.19	2.98	3.40	3.82	4.24	4.64	5.59	6.57	7.08	7.64	8.32	8.95	10.12	11.14	0.05	0.30	0.42	0.52		
3300	1.51	2.24	3.04	3.48	3.91	4.33	4.74	5.71	6.71	7.22	7.79	8.47	9.11	10.28	11.27	0.05	0.31	0.43	0.53		
3400	1.53	2.28	3.10	3.55	3.99	4.42	4.84	5.83	6.84	7.36	7.93	8.61	9.26	10.41	11.39	0.05	0.31	0.45	0.55		
3500	1.56	2.32	3.16	3.62	4.06	4.50	4.94	5.94	6.96	7.49	8.07	8.75	9.39	10.54	11.48	0.05	0.32	0.46	0.56		
3600	1.58	2.36	3.22	3.68	4.14	4.59	5.03	6.04	7.08	7.61	8.20	8.88	9.52	10.65	11.56	0.05	0.33	0.47	0.58		
3700	1.60	2.40	3.28	3.75	4.22	4.67	5.12	6.15	7.20	7.73	8.32	9.00	9.64	10.75	11.62	0.05	0.34	0.49	0.60		
3800	1.62	2.44	3.33	3.81	4.29	4.75	5.20	6.25	7.31	7.85	8.43	9.12	9.75	10.83	11.67	0.05	0.35	0.50	0.61		
3900	1.64	2.48	3.39	3.88	4.36	4.83	5.29	6.35	7.41	7.95	8.54	9.22	9.85	10.90	11.69	0.06	0.36	0.51	0.63		
4000	1.66	2.51	3.44	3.94	4.43	4.90	5.37	6.44	7.51	8.06	8.64	9.32	9.93	10.96	11.70	0.06	0.37	0.53	0.64		
4100	1.68	2.55	3.49	4.00	4.49	4.97	5.45	6.53	7.61	8.15	8.73	9.41	10.01	11.00	11.68	0.06	0.38	0.54	0.66		
4200	1.70	2.58	3.54	4.05	4.55	5.04	5.52	6.61	7.70	8.24	8.82	9.48	10.08	11.03	11.64	0.06	0.39	0.55	0.68		
4300	1.72	2.61	3.58	4.11	4.62	5.11	5.59	6.69	7.78	8.32	8.90	9.55	10.13	11.04	11.59	0.06	0.40	0.57	0.69		
4400	1.73	2.64	3.63	4.16	4.67	5.18	5.66	6.77	7.86	8.40	8.97	9.61	10.17	11.03	11.51	0.06	0.41	0.58	0.71		
4500	1.75	2.67	3.67	4.21	4.73	5.24	5.73	6.84	7.93	8.47	9.03	9.66	10.21	11.01	11.41	0.06	0.42	0.59	0.73		
4600	1.76	2.70	3.71	4.26	4.78	5.30	5.79	6.91	8.00	8.53	9.09	9.70	10.23	10.97		0.07	0.43	0.60	0.74		
4700	1.77	2.73	3.75	4.30	4.84	5.35	5.85	6.97	8.06	8.59	9.13	9.73	10.24	10.92		0.07	0.44	0.62	0.76		
4800	1.78	2.75	3.79	4.35	4.88	5.40	5.91	7.03	8.11	8.63	9.17	9.76	10.23	10.85		0.07	0.44	0.63	0.77		
4900	1.80	2.78	3.83	4.39	4.93	5.45	5.96	7.08	8.16	8.68	9.20	9.77	10.22	10.76		0.07	0.45	0.64	0.79		
5000	1.81	2.80	3.86	4.43	4.97	5.50	6.01	7.13	8.20	8.71	9.22	9.77	10.19	10.65		0.07	0.46	0.66	0.81		
5100	1.81	2.82	3.89	4.47	5.02	5.55	6.05	7.18	8.24	8.74	9.24	9.75	10.15			0.07	0.47	0.67	0.82		
5200	1.82	2.84	3.93	4.50	5.05	5.59	6.10	7.22	8.27	8.76	9.24	9.73	10.09			0.07	0.48	0.68	0.84		
5300	1.83	2.86	3.95	4.53	5.09	5.63	6.14	7.26	8.29	8.77	9.23	9.70	10.03			0.08	0.49	0.70	0.85		
5400	1.83	2.87	3.98	4.56	5.12	5.66	6.17	7.29	8.31	8.77	9.22	9.66	9.95			0.08	0.50	0.71	0.87		
5500	1.84	2.89	4.01	4.59	5.16	5.69	6.20	7.31	8.32	8.77	9.20	9.60				0.08	0.51	0.72	0.89		
5600	1.84	2.90	4.03	4.62	5.18	5.72	6.23	7.33	8.32	8.75	9.16	9.53				0.08	0.52	0.74	0.90		
5800	1.84	2.93	4.07	4.66	5.23	5.77	6.28	7.36	8.30	8.71	9.07	9.37				0.08	0.54	0.76	0.93		
6000	1.84	2.94	4.10	4.70	5.27	5.80	6.31	7.36	8.26	8.62	8.93					0.09	0.56	0.79	0.97		
6200	1.84	2.96	4.12	4.72	5.29	5.82	6.32	7.35	8.19	8.51	8.76					0.09	0.57	0.81	1.00		
6400	1.83	2.96	4.13	4.74	5.																

POWER RATINGS

optibelt **SK** PROFILE SPB, 5V/15N, 5V/15J

NOMINAL POWER RATING P_N [kW] FOR $\beta = 180^\circ$ AND $L_d = 3550$ mm

Table 43

Pulleys	v [m/s]	n_k [min ⁻¹]	Datum diameter of small pulley d_{dk} [mm]														Additional power [kW] per belt for speed ratio i					
			140	150	160	180	190	200	212	224	236	250	280	315	355	375	400	1.01 to 1.05	1.06 to 1.26	1.27 to 1.57	> 1.57	
Statically balanced		700	3.46	4.04	4.62	5.77	6.34	6.91	7.59	8.26	8.92	9.70	11.33	13.21	15.30	16.33	17.59	0.05	0.33	0.47	0.58	
		950	4.42	5.19	5.95	7.46	8.20	8.94	9.82	10.69	11.56	12.56	14.66	17.04	19.67	20.94	22.50	0.07	0.45	0.64	0.78	
		1450	6.09	7.20	8.29	10.44	11.49	12.53	13.76	14.96	16.15	17.50	20.30	23.36	26.59	28.08	29.83	0.11	0.69	0.97	1.20	
		2850	9.07	10.83	12.53	15.71	17.18	18.57	20.13	21.57	22.87	24.21	26.40	27.68				0.21	1.35	1.92	2.35	
		100	0.66	0.76	0.85	1.04	1.14	1.23	1.35	1.46	1.57	1.70	1.98	2.30	2.66	2.84	3.07	0.01	0.05	0.07	0.08	
		200	1.21	1.39	1.57	1.94	2.12	2.30	2.51	2.73	2.94	3.19	3.72	4.33	5.02	5.36	5.79	0.01	0.09	0.13	0.16	
		300	1.71	1.97	2.24	2.77	3.03	3.29	3.61	3.92	4.23	4.59	5.36	6.24	7.25	7.74	8.36	0.02	0.14	0.20	0.25	
		400	2.17	2.52	2.87	3.56	3.91	4.25	4.66	5.06	5.47	5.94	6.93	8.08	9.38	10.03	10.82	0.03	0.19	0.27	0.33	
		500	2.62	3.05	3.48	4.32	4.75	5.16	5.66	6.16	6.66	7.23	8.45	9.85	11.43	12.22	13.18	0.04	0.24	0.34	0.41	
		5	600	3.05	3.55	4.06	5.06	5.56	6.05	6.64	7.23	7.81	8.48	9.92	11.56	13.41	14.32	15.44	0.04	0.28	0.40	0.49
			700	3.46	4.04	4.62	5.77	6.34	6.91	7.59	8.26	8.92	9.70	11.33	13.21	15.30	16.33	17.59	0.05	0.33	0.47	0.58
			800	3.85	4.51	5.17	6.46	7.10	7.74	8.50	9.26	10.00	10.87	12.70	14.79	17.11	18.25	19.64	0.06	0.38	0.54	0.66
			900	4.23	4.96	5.69	7.13	7.84	8.55	9.39	10.22	11.05	12.00	14.02	16.30	18.84	20.07	21.57	0.07	0.43	0.61	0.74
			1000	4.60	5.40	6.20	7.78	8.56	9.33	10.25	11.16	12.06	13.10	15.28	17.75	20.47	21.79	23.39	0.07	0.47	0.67	0.82
		10	1100	4.95	5.83	6.69	8.41	9.25	10.09	11.08	12.06	13.03	14.15	16.50	19.13	22.01	23.40	25.07	0.08	0.52	0.74	0.91
			1200	5.29	6.24	7.17	9.01	9.92	10.82	11.88	12.93	13.97	15.16	17.65	20.44	23.46	24.89	26.62	0.09	0.57	0.81	0.99
			1300	5.62	6.63	7.63	9.60	10.57	11.52	12.65	13.77	14.87	16.13	18.76	21.67	24.79	26.26	28.02	0.10	0.62	0.87	1.07
			1400	5.94	7.01	8.08	10.16	11.19	12.20	13.40	14.57	15.73	17.06	19.80	22.82	26.02	27.51	29.27	0.10	0.66	0.94	1.15
			1500	6.24	7.38	8.51	10.71	11.79	12.85	14.11	15.34	16.55	17.93	20.78	23.88	27.12	28.62	30.35	0.11	0.71	1.01	1.24
		15	1600	6.54	7.73	8.92	11.23	12.36	13.48	14.79	16.07	17.33	18.76	21.69	24.86	28.11	29.58	31.26	0.12	0.76	1.08	1.32
			1700	6.82	8.07	9.31	11.73	12.91	14.07	15.44	16.77	18.07	19.54	22.54	25.74	28.96	30.39	31.99	0.12	0.81	1.14	1.40
			1800	7.08	8.40	9.69	12.21	13.44	14.64	16.05	17.42	18.76	20.27	23.31	26.52	29.68	31.04	32.53	0.13	0.85	1.21	1.48
			1900	7.34	8.71	10.05	12.67	13.93	15.18	16.63	18.04	19.40	20.94	24.02	27.20	30.25	31.53	32.86	0.14	0.90	1.28	1.57
			2000	7.58	9.00	10.39	13.10	14.41	15.68	17.17	18.61	20.00	21.56	24.64	27.77	30.68	31.84	32.99	0.15	0.95	1.34	1.65
		20	2100	7.81	9.28	10.72	13.51	14.85	16.15	17.67	19.14	20.55	22.11	25.19	28.24	30.94	31.96	32.89	0.15	0.99	1.41	1.73
			2200	8.02	9.54	11.03	13.89	15.26	16.59	18.14	19.62	21.04	22.61	25.65	28.58	31.05	31.90	32.57	0.16	1.04	1.48	1.81
			2300	8.22	9.79	11.31	14.24	15.64	17.00	18.57	20.06	21.48	23.05	26.03	28.81	30.98	31.63		0.17	1.09	1.55	1.90
			2400	8.41	10.02	11.58	14.57	16.00	17.37	18.95	20.45	21.87	23.41	26.31	28.91	30.74	31.16		0.18	1.14	1.61	1.98
			2500	8.58	10.23	11.83	14.88	16.32	17.70	19.29	20.79	22.20	23.72	26.50	28.88	30.31			0.18	1.18	1.68	2.06
		25	2600	8.74	10.42	12.06	15.15	16.61	18.00	19.59	21.08	22.47	23.95	26.60	28.71			0.19	1.23	1.75	2.14	
			2700	8.88	10.60	12.26	15.39	16.86	18.26	19.84	21.31	22.67	24.11	26.60	28.41			0.20	1.28	1.82	2.23	
			2800	9.01	10.76	12.45	15.61	17.08	18.48	20.05	21.50	22.82	24.19	26.49	27.96			0.21	1.33	1.88	2.31	
			2900	9.12	10.90	12.61	15.79	17.27	18.66	20.20	21.62	22.90	24.20	26.28	27.36			0.21	1.37	1.95	2.39	
			3000	9.22	11.02	12.75	15.95	17.42	18.79	20.31	21.69	22.91	24.13	25.96				0.22	1.42	2.02	2.47	
		30	3100	9.30	11.12	12.86	16.07	17.53	18.88	20.37	21.70	22.85	23.98					0.23	1.47	2.08	2.56	
			3200	9.36	11.21	12.96	16.16	17.60	18.93	20.38	21.64	22.72	23.74					0.23	1.52	2.15	2.64	
			3300	9.41	11.27	13.02	16.21	17.63	18.93	20.33	21.53	22.52	23.42					0.24	1.56	2.22	2.72	
			3400	9.44	11.31	13.07	16.23	17.63	18.89	20.22	21.35	22.25	23.01					0.25	1.61	2.29	2.80	
			3500	9.45	11.33	13.08	16.22	17.58	18.80	20.06	21.10	21.90	22.51					0.26	1.66	2.35	2.89	
		35	3600	9.45	11.33	13.08	16.17	17.49	18.66	19.84	20.78							0.26	1.71	2.42	2.97	
3700	9.42		11.30	13.04	16.08	17.36	18.47	19.57	20.40							0.27	1.75	2.49	3.05			
3800	9.38		11.25	12.98	15.95	17.18	18.22	19.23	19.94							0.28	1.80	2.55	3.13			
3900	9.31		11.18	12.89	15.78	16.95	17.93	18.83	19.41							0.29	1.85	2.62	3.21			
4000	9.23		11.09	12.77	15.58	16.68	17.58	18.36	18.81							0.29	1.89	2.69	3.30			
40	4100	9.13	10.97	12.62	15.33	16.36	17.17									0.30	1.94	2.76	3.38			
	4200	9.01	10.82	12.44	15.04	16.00	16.71									0.31	1.99	2.82	3.46			
	4300	8.86	10.65	12.23	14.71	15.58	16.19									0.32	2.04	2.89	3.54			
	4400	8.70	10.46	11.99	14.33	15.11	15.62									0.32	2.08	2.96	3.63			
	4500	8.51	10.24	11.72	13.92	14.60	14.98									0.33	2.13	3.03	3.71			
40	4600	8.30	9.99	11.42	13.45											0.34	2.18	3.09	3.79			
	4700	8.07	9.72	11.08	12.94											0.34	2.23	3.16	3.87			
	4800	7.82	9.41	10.72	12.38											0.35	2.27	3.23	3.96			
	4900	7.54	9.08	10.31	11.78											0.36	2.32	3.29	4.04			
	5000	7.24	8.72	9.87	11.13											0.37	2.37	3.36	4.12			
40	5100	6.92	8.33	9.40												0.37	2.42	3.43	4.20			
	5200	6.57	7.91	8.89												0.38	2.46	3.50	4.29			
	5300	6.19	7.46	8.34												0.39	2.51	3.56	4.37			
	5400	5.79	6.98	7.76												0.40	2.56	3.63	4.45			
	5500	5.37	6.47	7.14												0.40	2.61	3.70	4.53			

v > 42 m/s.
Please consult our
Application Engineering
Department.

v [m/s]

Dynamically balanced (for details see DIN 2211)

Pulleys

Note: Pulley diameters shown are outside diameters for sections 5V/15N, 5V/15J.

POWER RATINGS

optibelt **SK PROFILE SPC**

NOMINAL POWER RATING P_N [kW] FOR $\beta = 180^\circ$ AND $L_d = 5600$ mm

Table 44

Pulleys	v [m/s]	n_k [min ⁻¹]	Datum diameter of small pulley d_{dk} [mm]														Additional power [kW] per belt for speed ratio i				
			224	250	280	300	315	335	355	375	400	450	500	560	630	710	1.01 to 1.05	1.06 to 1.26	1.27 to 1.57	> 1.57	
Statically balanced		700	10.46	13.11	16.13	18.11	19.58	21.52	23.44	25.34	27.68	32.24	36.64	41.70	47.28	53.19	0.14	0.90	1.28	1.57	
		950	13.27	16.71	20.58	23.11	24.97	27.42	29.82	32.18	35.05	40.55	45.70	51.38	57.27	62.91	0.19	1.22	1.73	2.13	
		1450	17.79	22.48	27.64	30.92	33.30	36.35	39.26	42.02	45.25	50.94	55.51	59.36	61.37		0.29	1.86	2.65	3.25	
		2850	20.63	25.52	29.58	31.27	31.96										0.57	3.67	5.20	6.38	
		50	1.08	1.31	1.58	1.75	1.89	2.06	2.23	2.41	2.62	3.05	3.48	3.99	4.58	5.25	0.01	0.06	0.09	0.11	
		100	1.99	2.44	2.94	3.28	3.53	3.87	4.20	4.53	4.95	5.77	6.58	7.56	8.68	9.95	0.02	0.13	0.18	0.22	
		200	3.64	4.49	5.46	6.11	6.59	7.22	7.86	8.49	9.28	10.84	12.38	14.22	16.34	18.73	0.04	0.26	0.37	0.45	
		300	5.16	6.40	7.81	8.75	9.44	10.37	11.29	12.21	13.34	15.60	17.83	20.47	23.50	26.90	0.06	0.39	0.55	0.67	
		350	5.89	7.31	8.94	10.01	10.82	11.88	12.94	13.99	15.30	17.88	20.44	23.45	26.90	30.77	0.07	0.45	0.64	0.78	
		5	400	6.59	8.20	10.04	11.25	12.16	13.36	14.55	15.73	17.21	20.11	22.97	26.35	30.20	34.48	0.08	0.51	0.73	0.90
			450	7.28	9.07	11.11	12.46	13.47	14.80	16.12	17.44	19.07	22.28	25.44	29.15	33.37	38.04	0.09	0.58	0.82	1.01
			500	7.95	9.91	12.16	13.64	14.75	16.21	17.66	19.10	20.88	24.39	27.83	31.86	36.42	41.44	0.10	0.64	0.91	1.12
			550	8.60	10.74	13.19	14.80	16.00	17.59	19.16	20.72	22.65	26.44	30.15	34.48	39.34	44.66	0.11	0.71	1.00	1.23
			600	9.23	11.55	14.19	15.93	17.22	18.93	20.62	22.30	24.37	28.44	32.39	36.99	42.13	47.70	0.12	0.77	1.10	1.34
			650	9.85	12.34	15.17	17.03	18.42	20.24	22.05	23.84	26.05	30.37	34.56	39.40	44.78	50.55	0.13	0.84	1.19	1.45
			700	10.46	13.11	16.13	18.11	19.58	21.52	23.44	25.34	27.68	32.24	36.64	41.70	47.28	53.19	0.14	0.90	1.28	1.57
			750	11.05	13.87	17.06	19.16	20.72	22.77	24.80	26.80	29.26	34.04	38.64	43.89	49.62	55.61	0.15	0.96	1.37	1.68
		10	800	11.63	14.60	17.98	20.19	21.83	23.99	26.11	28.21	30.78	35.77	40.54	45.95	51.80	57.81	0.16	1.03	1.46	1.79
			850	12.19	15.32	18.87	21.19	22.91	25.17	27.39	29.58	32.26	37.44	42.36	47.89	53.80	59.77	0.17	1.09	1.55	1.90
			900	12.74	16.02	19.74	22.16	23.96	26.31	28.63	30.90	33.68	39.03	44.08	49.71	55.63	61.47	0.18	1.16	1.64	2.01
			950	13.27	16.71	20.58	23.11	24.97	27.42	29.82	32.18	35.05	40.55	45.70	51.38	57.27	62.91	0.19	1.22	1.73	2.13
		15	1000	13.79	17.37	21.40	24.03	25.96	28.50	30.98	33.41	36.36	41.99	47.21	52.92	58.71	64.08	0.20	1.29	1.83	2.24
			1050	14.30	18.02	22.20	24.91	26.92	29.53	32.09	34.58	37.61	43.34	48.62	54.30	59.94	64.95	0.21	1.35	1.92	2.35
			1100	14.79	18.64	22.97	25.77	27.84	30.53	33.16	35.71	38.80	44.62	49.92	55.54	60.96	65.53	0.22	1.41	2.01	2.46
			1150	15.26	19.25	23.72	26.61	28.73	31.49	34.18	36.78	39.93	45.81	51.10	56.61	61.76	65.79	0.23	1.48	2.10	2.57
			1200	15.72	19.84	24.44	27.41	29.58	32.41	35.15	37.80	40.99	46.90	52.16	57.52	62.33	65.72	0.24	1.54	2.19	2.69
			1250	16.17	20.41	25.13	28.17	30.40	33.28	36.07	38.76	41.98	47.91	53.10	58.25	62.65	65.31	0.25	1.61	2.28	2.80
			1300	16.60	20.96	25.80	28.91	31.18	34.12	36.95	39.67	42.91	48.82	53.90	58.81	62.73		0.26	1.67	2.37	2.91
			1350	17.01	21.49	26.44	29.62	31.93	34.91	37.77	40.52	43.77	49.63	54.58	59.19	62.55		0.27	1.74	2.46	3.02
		20	1400	17.41	21.99	27.06	30.29	32.63	35.65	38.54	41.30	44.55	50.34	55.12	59.37	62.10		0.28	1.80	2.56	3.13
			1450	17.79	22.48	27.64	30.92	33.30	36.35	39.26	42.02	45.25	50.94	55.51	59.36	61.37		0.29	1.86	2.65	3.25
			1500	18.16	22.94	28.20	31.53	33.93	37.00	39.92	42.68	45.88	51.44	55.76	59.15		0.30	1.93	2.74	3.36	
			1550	18.51	23.39	28.72	32.09	34.52	37.61	40.53	43.27	46.43	51.83	55.86			0.31	1.99	2.83	3.47	
			1600	18.84	23.81	29.22	32.62	35.06	38.16	41.07	43.79	46.90	52.10	55.81			0.32	2.06	2.92	3.58	
			1650	19.16	24.20	29.68	33.11	35.56	38.66	41.56	44.24	47.29	52.25	55.59			0.33	2.12	3.01	3.69	
			1700	19.45	24.58	30.11	33.56	36.02	39.11	41.98	44.62	47.58	52.28	55.21			0.34	2.19	3.10	3.80	
			1750	19.73	24.92	30.51	33.98	36.43	39.51	42.35	44.93	47.79	52.19	54.67			0.35	2.25	3.19	3.92	
		25	1800	19.99	25.25	30.88	34.35	36.80	39.85	42.64	45.16	47.91	51.97			0.36	2.31	3.29	4.03		
			1850	20.24	25.55	31.21	34.68	37.12	40.14	42.87	45.32	47.94	51.62			0.37	2.38	3.38	4.14		
			1900	20.46	25.82	31.51	34.97	37.39	40.37	43.04	45.39	47.87	51.14			0.38	2.44	3.47	4.25		
1950	20.66		26.07	31.77	35.22	37.61	40.54	43.13	45.39	47.70	50.52			0.39	2.51	3.56	4.36				
2000	20.85		26.29	31.99	35.42	37.79	40.65	43.16	45.30	47.44	49.76			0.40	2.57	3.65	4.48				
2050	21.01		26.49	32.18	35.58	37.91	40.69	43.11	45.13	47.07				0.41	2.64	3.74	4.59				
2100	21.16		26.66	32.34	35.69	37.97	40.68	42.99	44.87	46.60				0.42	2.70	3.83	4.70				
2150	21.28		26.79	32.45	35.76	37.99	40.60	42.79	44.52	46.02				0.43	2.77	3.92	4.81				
30	2200	21.38	26.91	32.52	35.78	37.95	40.46	42.51	44.08	45.33				0.44	2.83	4.02	4.92				
	2250	21.46	26.99	32.56	35.75	37.85	40.25	42.16	43.55	44.53				0.45	2.89	4.11	5.04				
	2300	21.52	27.04	32.55	35.67	37.70	39.97	41.73						0.46	2.96	4.20	5.15				
	2350	21.56	27.06	32.50	35.54	37.49	39.63	41.21						0.47	3.02	4.29	5.26				
	2400	21.57	27.05	32.41	35.36	37.22	39.21	40.61						0.48	3.09	4.38	5.37				
	2450	21.57	27.02	32.28	35.13	36.89	38.72	39.93						0.49	3.15	4.47	5.48				
	2500	21.53	26.94	32.10	34.84	36.50	38.16	39.16						0.50	3.22	4.56	5.60				
	2550	21.48	26.84	31.88	34.50	36.05								0.51	3.28	4.66	5.71				
35	2600	21.40	26.71	31.62	34.10	35.53								0.52	3.34	4.75	5.82				
	2650	21.30	26.54	31.30	33.65	34.95								0.53	3.41	4.84	5.93				
	2700	21.17	26.33	30.94	33.14	34.30								0.54	3.47	4.93	6.04				
	2750	21.02	26.10	30.54	32.58	33.59								0.55	3.54	5.02	6.16				
	2800	20.84	25.83	30.08										0.56	3.60	5.11	6.27				
	2850	20.63	25.52	29.58										0.57	3.67	5.20	6.38				
	2900	20.40	25.18	29.03										0.58	3.73	5.29	6.49				
	2950	20.14	24.80	28.42										0.59	3.79	5.39	6.60				
40	3000	19.86	24.38	27.77										0.60	3.86	5.48	6.71				
	3050	19.55	23.93	27.06										0.61	3.92	5.57	6.83				
	3100	19.21	23.43	26.30										0.62	3.99	5.66	6.94				
	3150	18.84	22.90	25.49										0.63	4.05	5.75	7.05				
	3200	18.44	22.33	24.62										0.64	4.12	5.84	7.16				
	3250	18.02	21.72	23.69										0.65	4.18	5.93	7.27				
	3300	17.56	21.07											0.66	4.24	6.02	7.39				
	3350	17.08	20.38											0.67	4.31	6.12	7.50				
3400	16.56	19.65											0.68	4.37	6.21	7.61					
3450	16.02	18.87											0.69	4.44	6.30	7.72					
3500	15.44	18.05											0.70	4.50	6.39	7.83					
v > 42 m/s. Please consult our Application Engineering Department.																					
v [m/s]																					
Dynamically balanced (for details see DIN 2211)																					
Pulleys																					

POWER RATINGS

optibelt **SK PROFILE 8V/25N, 8V/25J**

NOMINAL POWER RATING P_N [kW] FOR $\beta = 180^\circ$ AND 8V 2500/6350 mm L_d

Table 45

Pulleys	v [m/s]	n_k [min ⁻¹]	Outside diameter of small pulley d_{ok} [mm]											Additional power [kW] per belt for speed ratio i					
			335	355	375	425	450	475	500	530	560	600	630	710	800	1.01 to 1.05	1.06 to 1.26	1.27 to 1.57	> 1.57
Statically balanced	700	25.67	28.61	31.52	38.62	42.08	45.49	48.82	52.74	56.57	61.51	65.09	74.10	83.23	0.28	1.83	2.60	3.18	
		950	32.09	35.77	39.37	48.03	52.17	56.17	60.03	64.47	68.68	73.95	77.62	86.13	93.33	0.38	2.48	3.52	4.32
	1450	40.47	44.90	49.10	58.51	62.60	66.25	69.44	72.63	75.10	77.18	77.79	5.38	6.60					
	50	2.63	2.89	3.16	3.82	4.15	4.48	4.80	5.19	5.58	6.10	6.48	7.51	8.65	0.02	0.13	0.19	0.23	
	100	4.87	5.38	5.89	7.15	7.78	8.41	9.03	9.78	10.52	11.51	12.24	14.19	16.37	0.04	0.26	0.37	0.45	
	150	6.97	7.71	8.46	10.30	11.22	12.13	13.03	14.12	15.20	16.63	17.70	20.53	23.68	0.06	0.39	0.56	0.68	
	200	8.97	9.94	10.91	13.31	14.51	15.69	16.88	18.29	19.69	21.56	22.94	26.61	30.68	0.08	0.52	0.74	0.91	
	250	10.89	12.08	13.27	16.22	17.68	19.14	20.59	22.31	24.03	26.30	28.00	32.46	37.40	0.10	0.65	0.93	1.14	
	5	300	12.74	14.15	15.56	19.04	20.76	22.47	24.18	26.21	28.22	30.89	32.87	38.09	43.84	0.12	0.78	1.11	1.36
		350	14.54	16.16	17.78	21.77	23.74	25.71	27.66	29.98	32.28	35.32	37.57	43.49	49.98	0.14	0.91	1.30	1.59
		400	16.28	18.11	19.93	24.42	26.64	28.84	31.02	33.62	36.19	39.58	42.10	48.66	55.82	0.16	1.05	1.48	1.82
		450	17.97	20.00	22.01	26.99	29.44	31.87	34.28	37.14	39.97	43.69	46.44	53.59	61.33	0.18	1.18	1.67	2.05
		500	19.61	21.83	24.04	29.48	32.16	34.81	37.43	40.54	43.60	47.62	50.59	58.27	66.50	0.20	1.31	1.86	2.27
	10	550	21.20	23.61	26.00	31.89	34.78	37.64	40.46	43.80	47.08	51.38	54.54	62.67	71.30	0.22	1.44	2.04	2.50
		600	22.74	25.33	27.90	34.22	37.31	40.36	43.37	46.92	50.41	54.95	58.28	66.79	75.70	0.24	1.57	2.23	2.73
		650	24.23	27.00	29.74	36.46	39.75	42.98	46.16	49.91	53.57	58.33	61.80	70.61	79.69	0.26	1.70	2.41	2.96
		700	25.67	28.61	31.52	38.62	42.08	45.49	48.82	52.74	56.57	61.51	65.09	74.10	83.23	0.28	1.83	2.60	3.18
		750	27.06	30.16	33.23	40.69	44.32	47.87	51.35	55.42	59.38	64.46	68.13	77.26	86.31	0.30	1.96	2.78	3.41
	15	800	28.40	31.66	34.87	42.67	46.45	50.14	53.74	57.94	62.01	67.20	70.92	80.06	88.88	0.32	2.09	2.97	3.64
		850	29.68	33.09	36.44	44.56	48.47	52.28	55.99	60.30	64.44	69.70	73.44	82.49	90.92	0.34	2.22	3.15	3.87
		900	30.91	34.46	37.94	46.34	50.38	54.29	58.09	62.47	66.67	71.95	75.67	84.52	92.42	0.36	2.35	3.34	4.09
		950	32.09	35.77	39.37	48.03	52.17	56.17	60.03	64.47	68.68	73.95	77.62	86.13	93.33	0.38	2.48	3.52	4.32
		1000	33.21	37.01	40.72	49.61	53.84	57.90	61.81	66.27	70.48	75.68	79.25	87.31	93.63	0.40	2.61	3.71	4.55
	20	1050	34.27	38.18	42.00	51.09	55.38	59.49	63.42	67.87	72.04	77.12	80.56	88.04	93.28	0.42	2.74	3.90	4.78
		1100	35.27	39.29	43.19	52.45	56.79	60.93	64.85	69.27	73.36	78.28	81.53	88.30	92.28	0.44	2.88	4.08	5.00
		1150	36.21	40.32	44.30	53.69	58.06	62.20	66.11	70.46	74.44	79.13	82.16	88.06	90.56	0.46	3.01	4.27	5.23
		1200	37.09	41.28	45.33	54.82	59.20	63.32	67.17	71.42	75.25	79.66	82.42	87.31	88.14	0.49	3.14	4.45	5.46
		1250	37.90	42.16	46.27	55.82	60.19	64.27	68.04	72.16	75.80	79.87	82.31	86.03	0.51	3.27	4.64	5.69	
	25	1300	38.65	42.97	47.12	56.69	61.03	65.04	68.71	72.65	76.06	79.74	81.80	0.53	3.40	4.82	5.91		
		1350	39.33	43.70	47.88	57.44	61.71	65.63	69.17	72.90	76.04	79.25	80.89	0.55	3.53	5.01	6.14		
		1400	39.93	44.34	48.54	58.04	62.24	66.04	69.42	72.90	75.72	79.56	0.57	3.66	5.19	6.37			
		1450	40.47	44.90	49.10	58.51	62.60	66.25	69.44	72.63	75.10	77.79	0.59	3.79	5.38	6.60			
		1500	40.93	45.37	49.56	58.84	62.80	66.27	69.24					0.61	3.92	5.57	6.82		
	30	1550	41.31	45.75	49.91	59.01	62.81	66.08	68.80					0.63	4.05	5.75	7.05		
		1600	41.62	46.04	50.16	59.04	62.65	65.69	68.11					0.65	4.18	5.94	7.28		
		1650	41.85	46.24	50.30	58.90	62.31	65.08	67.18					0.67	4.31	6.12	7.51		
		1700	41.99	46.34	50.33	58.61	61.77	64.25	65.99					0.69	4.44	6.31	7.73		
		1750	42.05	46.35	50.24	58.15	61.05	63.19	64.54					0.71	4.57	6.49	7.96		
	35	1800	42.03	46.25	50.04	57.52	60.12							0.73	4.70	6.68	8.19		
		1850	41.92	46.05	49.71	56.72	58.98							0.75	4.84	6.86	8.42		
1900		41.72	45.74	49.26	55.74	57.64							0.77	4.97	7.05	8.64			
1950		41.42	45.32	48.69	54.58	56.08							0.79	5.10	7.23	8.87			
2000		41.04	44.79	47.98	53.23	54.31							0.81	5.23	7.42	9.10			
40	2050	40.55	44.15	47.14									0.83	5.36	7.61	9.33			
	2100	39.97	43.40	46.16									0.85	5.49	7.79	9.55			
	2150	39.29	42.52	45.05									0.87	5.62	7.98	9.78			
	2200	38.50	41.53	43.79									0.89	5.75	8.16	10.01			
	2250	37.62	40.41	42.40									0.91	5.88	8.35	10.23			

v > 42 m/s.
Please consult our
Application Engineering
Department.

40

Dynamically balanced (for details see USA standard RMA/MPTA)

v [m/s]

Pulleys

POWER RATINGS

optibelt VB PROFILE 5 – RAW EDGE, MOULDED COGGED

NOMINAL POWER RATING P_N [kW] FOR $\beta = 180^\circ$ AND $L_d = 312$ mm

Table 46

Pulleys	v [m/s]	n_k [min ⁻¹]	Datum diameter of small pulley d_{dk} [mm]									Additional power [kW] per belt for speed ratio i					
			16	18	20	22.4	25	28	31.5	33.5	40	45	1.01 to 1.05	1.06 to 1.26	1.27 to 1.57	> 1.57	
Statically balanced	②	700	0.02	0.02	0.03	0.03	0.04	0.04	0.05	0.06	0.07	0.08	0.000	0.001	0.002	0.003	
		950	0.02	0.03	0.04	0.04	0.05	0.06	0.07	0.07	0.09	0.10	0.000	0.002	0.002	0.004	
		1450	0.03	0.04	0.05	0.06	0.07	0.08	0.10	0.11	0.13	0.15	0.001	0.002	0.004	0.005	
		2850	0.06	0.07	0.09	0.11	0.13	0.15	0.18	0.19	0.24	0.28	0.001	0.005	0.007	0.011	
		200	0.01	0.01	0.01	0.01	0.01	0.02	0.02	0.02	0.02	0.03	0.03	0.000	0.000	0.000	0.001
		300	0.01	0.01	0.01	0.01	0.02	0.02	0.02	0.02	0.03	0.03	0.04	0.000	0.001	0.001	0.001
		400	0.01	0.01	0.02	0.02	0.02	0.03	0.03	0.03	0.04	0.04	0.05	0.000	0.001	0.001	0.001
		500	0.01	0.02	0.02	0.02	0.03	0.03	0.04	0.04	0.05	0.06	0.06	0.000	0.001	0.001	0.002
		600	0.02	0.02	0.02	0.03	0.03	0.04	0.05	0.05	0.06	0.07	0.07	0.000	0.001	0.001	0.002
		700	0.02	0.02	0.03	0.03	0.04	0.04	0.05	0.06	0.07	0.08	0.08	0.000	0.001	0.002	0.003
		800	0.02	0.03	0.03	0.04	0.04	0.05	0.06	0.06	0.08	0.09	0.09	0.000	0.001	0.002	0.003
		900	0.02	0.03	0.03	0.04	0.05	0.06	0.06	0.07	0.09	0.10	0.10	0.000	0.002	0.002	0.003
		1000	0.03	0.03	0.04	0.04	0.05	0.06	0.07	0.08	0.10	0.11	0.11	0.000	0.002	0.002	0.004
		1100	0.03	0.03	0.04	0.05	0.06	0.07	0.08	0.08	0.10	0.12	0.12	0.000	0.002	0.003	0.004
		1200	0.03	0.04	0.04	0.05	0.06	0.07	0.08	0.09	0.11	0.13	0.13	0.001	0.002	0.003	0.004
		1300	0.03	0.04	0.05	0.06	0.07	0.08	0.09	0.10	0.12	0.14	0.14	0.001	0.002	0.003	0.005
		1400	0.03	0.04	0.05	0.06	0.07	0.08	0.10	0.10	0.13	0.15	0.15	0.001	0.002	0.003	0.005
		1500	0.03	0.04	0.05	0.06	0.07	0.09	0.10	0.11	0.14	0.16	0.16	0.001	0.003	0.004	0.006
		1600	0.04	0.05	0.06	0.07	0.08	0.09	0.11	0.12	0.14	0.17	0.17	0.001	0.003	0.004	0.006
		1700	0.04	0.05	0.06	0.07	0.08	0.10	0.11	0.12	0.15	0.18	0.18	0.001	0.003	0.004	0.006
		1800	0.04	0.05	0.06	0.07	0.09	0.10	0.12	0.13	0.16	0.18	0.18	0.001	0.003	0.004	0.007
		1900	0.04	0.05	0.06	0.08	0.09	0.11	0.12	0.13	0.17	0.19	0.19	0.001	0.003	0.005	0.007
		2000	0.04	0.06	0.07	0.08	0.09	0.11	0.13	0.14	0.18	0.20	0.20	0.001	0.003	0.005	0.007
		2100	0.05	0.06	0.07	0.08	0.10	0.12	0.14	0.15	0.18	0.21	0.21	0.001	0.004	0.005	0.008
		2200	0.05	0.06	0.07	0.09	0.10	0.12	0.14	0.15	0.19	0.22	0.22	0.001	0.004	0.005	0.008
		2300	0.05	0.06	0.07	0.09	0.11	0.13	0.15	0.16	0.20	0.23	0.23	0.001	0.004	0.006	0.009
		2400	0.05	0.06	0.08	0.09	0.11	0.13	0.15	0.17	0.21	0.24	0.24	0.001	0.004	0.006	0.009
		2500	0.05	0.07	0.08	0.10	0.11	0.13	0.16	0.17	0.21	0.25	0.25	0.001	0.004	0.006	0.009
		2600	0.05	0.07	0.08	0.10	0.12	0.14	0.16	0.18	0.22	0.25	0.25	0.001	0.004	0.006	0.010
		2700	0.06	0.07	0.09	0.10	0.12	0.14	0.17	0.18	0.23	0.26	0.26	0.001	0.005	0.007	0.010
		2800	0.06	0.07	0.09	0.11	0.13	0.15	0.17	0.19	0.24	0.27	0.27	0.001	0.005	0.007	0.010
		2900	0.06	0.07	0.09	0.11	0.13	0.15	0.18	0.19	0.24	0.28	0.28	0.001	0.005	0.007	0.011
		3000	0.06	0.08	0.09	0.11	0.13	0.16	0.19	0.20	0.25	0.29	0.29	0.001	0.005	0.007	0.011
		3100	0.06	0.08	0.10	0.12	0.14	0.16	0.19	0.21	0.26	0.30	0.30	0.001	0.005	0.007	0.012
		3200	0.06	0.08	0.10	0.12	0.14	0.17	0.20	0.21	0.27	0.31	0.31	0.001	0.005	0.008	0.012
		3300	0.06	0.08	0.10	0.12	0.14	0.17	0.20	0.22	0.27	0.31	0.31	0.001	0.006	0.008	0.012
		3400	0.07	0.08	0.10	0.13	0.15	0.18	0.21	0.22	0.28	0.32	0.32	0.002	0.006	0.008	0.013
		3500	0.07	0.09	0.11	0.13	0.15	0.18	0.21	0.23	0.29	0.33	0.33	0.002	0.006	0.008	0.013
		3600	0.07	0.09	0.11	0.13	0.16	0.18	0.22	0.24	0.29	0.34	0.34	0.002	0.006	0.009	0.013
		3700	0.07	0.09	0.11	0.13	0.16	0.19	0.22	0.24	0.30	0.35	0.35	0.002	0.006	0.009	0.014
		3800	0.07	0.09	0.11	0.14	0.16	0.19	0.23	0.25	0.31	0.36	0.36	0.002	0.006	0.009	0.014
		3900	0.07	0.09	0.12	0.14	0.17	0.20	0.23	0.25	0.32	0.36	0.36	0.002	0.007	0.009	0.015
		4000	0.07	0.10	0.12	0.14	0.17	0.20	0.24	0.26	0.32	0.37	0.37	0.002	0.007	0.010	0.015
		4100	0.08	0.10	0.12	0.15	0.17	0.21	0.24	0.26	0.33	0.38	0.38	0.002	0.007	0.010	0.015
		4200	0.08	0.10	0.12	0.15	0.18	0.21	0.25	0.27	0.34	0.39	0.39	0.002	0.007	0.010	0.016
		4300	0.08	0.10	0.13	0.15	0.18	0.21	0.25	0.27	0.34	0.40	0.40	0.002	0.007	0.010	0.016
		4400	0.08	0.10	0.13	0.16	0.18	0.22	0.26	0.28	0.35	0.40	0.40	0.002	0.007	0.011	0.016
		4500	0.08	0.11	0.13	0.16	0.19	0.22	0.26	0.28	0.36	0.41	0.41	0.002	0.008	0.011	0.017
		4600	0.08	0.11	0.13	0.16	0.19	0.23	0.27	0.29	0.36	0.42	0.42	0.002	0.008	0.011	0.017
		4700	0.08	0.11	0.13	0.16	0.20	0.23	0.27	0.30	0.37	0.43	0.43	0.002	0.008	0.011	0.018
		4800	0.09	0.11	0.14	0.17	0.20	0.24	0.28	0.30	0.38	0.44	0.44	0.002	0.008	0.012	0.018
		4900	0.09	0.11	0.14	0.17	0.20	0.24	0.28	0.31	0.38	0.44	0.44	0.002	0.008	0.012	0.018
		5000	0.09	0.12	0.14	0.17	0.21	0.24	0.29	0.31	0.39	0.45	0.45	0.002	0.008	0.012	0.019
		5100	0.09	0.12	0.14	0.18	0.21	0.25	0.29	0.32	0.40	0.46	0.46	0.002	0.009	0.012	0.019
		5200	0.09	0.12	0.15	0.18	0.21	0.25	0.30	0.32	0.40	0.47	0.47	0.002	0.009	0.013	0.019
		5300	0.09	0.12	0.15	0.18	0.22	0.26	0.30	0.33	0.41	0.47	0.47	0.002	0.009	0.013	0.020
		5400	0.09	0.12	0.15	0.18	0.22	0.26	0.31	0.33	0.42	0.48	0.48	0.002	0.009	0.013	0.020
		5500	0.10	0.12	0.15	0.19	0.22	0.26	0.31	0.34	0.42	0.49	0.49	0.002	0.009	0.013	0.021
		5600	0.10	0.13	0.16	0.19	0.23	0.27	0.32	0.34	0.43	0.50	0.50	0.002	0.009	0.014	0.021
		5700	0.10	0.13	0.16	0.19	0.23	0.27	0.32	0.35	0.44	0.50	0.50	0.003	0.010	0.014	0.021
5800	0.10	0.13	0.16	0.19	0.23	0.28	0.33	0.35	0.44	0.51	0.51	0.003	0.010	0.014	0.022		
5900	0.10	0.13	0.16	0.20	0.24	0.28	0.33	0.36	0.45	0.52	0.52	0.003	0.010	0.014	0.022		
6000	0.10	0.13	0.16	0.20	0.24	0.28	0.34	0.36	0.46	0.53	0.53	0.003	0.010	0.015	0.022		
Statically balanced												v [m/s]					
Pulleys												Pulleys					

POWER RATINGS

optibelt **VB** PROFILE Y/6 – RAW EDGE, MOULDED COGGED

NOMINAL POWER RATING P_N [kW] FOR $\beta = 180^\circ$ AND $L_d = 315$ mm

Table 47

Pulleys	v [m/s]	n_k [min ⁻¹]	Datum diameter of small pulley d_{dk} [mm]									Additional power [kW] per belt for speed ratio i			
			20	22.4	25	28	31.5	35.5	40	45	50	56	1.01 to 1.05	1.06 to 1.26	1.27 to 1.57
②	700	0.03	0.03	0.04	0.05	0.06	0.08	0.09	0.11	0.12	0.14	0.001	0.003	0.005	0.008
	950	0.03	0.04	0.05	0.07	0.08	0.10	0.12	0.14	0.16	0.18	0.001	0.005	0.007	0.011
	1450	0.05	0.06	0.08	0.10	0.12	0.15	0.17	0.20	0.24	0.27	0.002	0.007	0.010	0.016
	2850	0.08	0.11	0.14	0.18	0.22	0.27	0.32	0.38	0.43	0.50	0.004	0.014	0.020	0.032
	200	0.01	0.01	0.01	0.02	0.02	0.02	0.02	0.03	0.03	0.04	0.000	0.001	0.001	0.002
	300	0.01	0.02	0.02	0.02	0.03	0.03	0.04	0.05	0.06	0.06	0.000	0.001	0.002	0.003
	400	0.02	0.02	0.03	0.03	0.04	0.05	0.05	0.06	0.07	0.08	0.001	0.002	0.003	0.004
	500	0.02	0.02	0.03	0.04	0.05	0.06	0.07	0.08	0.09	0.10	0.001	0.002	0.004	0.006
	600	0.02	0.03	0.04	0.04	0.05	0.07	0.08	0.09	0.10	0.12	0.001	0.003	0.004	0.007
	700	0.03	0.03	0.04	0.05	0.06	0.08	0.09	0.11	0.12	0.14	0.001	0.003	0.005	0.008
	800	0.03	0.04	0.05	0.06	0.07	0.08	0.10	0.12	0.14	0.16	0.001	0.004	0.006	0.009
	900	0.03	0.04	0.05	0.06	0.08	0.09	0.11	0.13	0.15	0.18	0.001	0.004	0.006	0.010
	1000	0.03	0.04	0.06	0.07	0.09	0.10	0.12	0.15	0.17	0.19	0.001	0.005	0.007	0.011
	1100	0.04	0.05	0.06	0.08	0.09	0.11	0.14	0.16	0.18	0.21	0.001	0.005	0.008	0.012
	1200	0.04	0.05	0.07	0.08	0.10	0.12	0.15	0.17	0.20	0.23	0.002	0.006	0.009	0.013
	1300	0.04	0.06	0.07	0.09	0.11	0.13	0.16	0.19	0.21	0.25	0.002	0.006	0.009	0.014
	1400	0.04	0.06	0.08	0.09	0.12	0.14	0.17	0.20	0.23	0.26	0.002	0.007	0.010	0.016
	1500	0.05	0.06	0.08	0.10	0.12	0.15	0.18	0.21	0.24	0.28	0.002	0.007	0.011	0.017
	1600	0.05	0.07	0.09	0.11	0.13	0.16	0.19	0.22	0.24	0.30	0.002	0.008	0.011	0.018
	1700	0.05	0.07	0.09	0.11	0.14	0.17	0.20	0.24	0.27	0.31	0.002	0.008	0.012	0.019
	1800	0.05	0.07	0.09	0.12	0.15	0.18	0.21	0.25	0.29	0.33	0.002	0.009	0.013	0.020
	1900	0.06	0.08	0.10	0.12	0.15	0.19	0.22	0.26	0.30	0.35	0.003	0.009	0.014	0.021
	2000	0.06	0.08	0.10	0.13	0.16	0.19	0.23	0.27	0.32	0.36	0.003	0.010	0.014	0.022
	2100	0.06	0.08	0.11	0.14	0.17	0.20	0.24	0.29	0.33	0.38	0.003	0.010	0.015	0.023
	2200	0.06	0.09	0.11	0.14	0.17	0.21	0.25	0.30	0.34	0.40	0.003	0.011	0.016	0.024
	2300	0.07	0.09	0.12	0.15	0.18	0.22	0.26	0.31	0.36	0.41	0.003	0.011	0.016	0.026
	2400	0.07	0.09	0.12	0.15	0.19	0.23	0.27	0.32	0.37	0.43	0.003	0.012	0.017	0.027
	2500	0.07	0.10	0.13	0.16	0.19	0.24	0.28	0.33	0.38	0.44	0.003	0.012	0.018	0.028
	2600	0.07	0.10	0.13	0.16	0.20	0.24	0.29	0.35	0.40	0.46	0.003	0.013	0.019	0.029
	2700	0.08	0.10	0.13	0.17	0.21	0.25	0.30	0.36	0.41	0.48	0.004	0.013	0.019	0.030
	2800	0.08	0.11	0.14	0.17	0.22	0.26	0.31	0.37	0.43	0.49	0.004	0.014	0.020	0.031
	2900	0.08	0.11	0.14	0.18	0.22	0.27	0.32	0.38	0.44	0.51	0.004	0.014	0.021	0.032
	3000	0.08	0.11	0.15	0.18	0.23	0.28	0.33	0.39	0.45	0.52	0.004	0.015	0.021	0.033
	3100	0.09	0.12	0.15	0.19	0.24	0.29	0.34	0.40	0.47	0.54	0.004	0.015	0.022	0.034
	3200	0.09	0.12	0.16	0.20	0.24	0.29	0.35	0.42	0.48	0.55	0.004	0.016	0.023	0.036
	3300	0.09	0.12	0.16	0.20	0.25	0.30	0.36	0.43	0.49	0.57	0.004	0.016	0.024	0.037
	3400	0.09	0.13	0.16	0.21	0.25	0.31	0.37	0.44	0.50	0.58	0.004	0.017	0.024	0.038
	3500	0.09	0.13	0.17	0.21	0.26	0.32	0.38	0.45	0.52	0.60	0.005	0.017	0.025	0.039
	3600	0.10	0.13	0.17	0.22	0.27	0.33	0.39	0.46	0.53	0.61	0.005	0.018	0.026	0.040
	3700	0.10	0.14	0.18	0.22	0.27	0.33	0.40	0.47	0.54	0.62	0.005	0.018	0.026	0.041
3800	0.10	0.14	0.18	0.23	0.28	0.34	0.41	0.48	0.55	0.64	0.005	0.019	0.027	0.042	
3900	0.10	0.14	0.18	0.23	0.29	0.35	0.42	0.49	0.57	0.65	0.005	0.019	0.028	0.043	
4000	0.10	0.14	0.19	0.24	0.29	0.36	0.43	0.50	0.58	0.67	0.005	0.020	0.029	0.044	
4100	0.11	0.15	0.19	0.24	0.30	0.36	0.44	0.51	0.59	0.68	0.005	0.020	0.029	0.045	
4200	0.11	0.15	0.19	0.25	0.31	0.37	0.44	0.52	0.60	0.69	0.006	0.021	0.030	0.047	
4300	0.11	0.15	0.20	0.25	0.31	0.38	0.45	0.54	0.61	0.71	0.006	0.021	0.031	0.048	
4400	0.11	0.16	0.20	0.26	0.32	0.39	0.46	0.55	0.63	0.72	0.006	0.022	0.031	0.049	
4500	0.11	0.16	0.21	0.26	0.32	0.39	0.47	0.56	0.64	0.73	0.006	0.022	0.032	0.050	
4600	0.12	0.16	0.21	0.27	0.33	0.40	0.48	0.57	0.65	0.75	0.006	0.023	0.033	0.051	
4700	0.12	0.16	0.21	0.27	0.34	0.41	0.49	0.58	0.66	0.76	0.006	0.023	0.034	0.052	
4800	0.12	0.17	0.22	0.28	0.34	0.42	0.50	0.59	0.67	0.77	0.006	0.024	0.034	0.053	
4900	0.12	0.17	0.22	0.28	0.35	0.42	0.51	0.60	0.68	0.79	0.006	0.024	0.035	0.054	
5000	0.12	0.17	0.22	0.28	0.35	0.43	0.51	0.61	0.70	0.80	0.007	0.025	0.036	0.055	
5100	0.12	0.17	0.23	0.29	0.36	0.44	0.52	0.62	0.71	0.81	0.007	0.025	0.037	0.057	
5200	0.13	0.18	0.23	0.29	0.36	0.44	0.53	0.63	0.72	0.82	0.007	0.026	0.037	0.058	
5300	0.13	0.18	0.24	0.30	0.37	0.45	0.54	0.64	0.73	0.84	0.007	0.026	0.038	0.059	
5400	0.13	0.18	0.24	0.30	0.38	0.46	0.55	0.65	0.74	0.85	0.007	0.027	0.039	0.060	
5500	0.13	0.19	0.24	0.31	0.38	0.47	0.56	0.65	0.75	0.86	0.007	0.027	0.039	0.061	
5600	0.13	0.19	0.25	0.31	0.39	0.47	0.56	0.66	0.76	0.87	0.007	0.028	0.040	0.062	
5700	0.14	0.19	0.25	0.32	0.39	0.48	0.57	0.67	0.77	0.88	0.008	0.028	0.041	0.063	
5800	0.14	0.19	0.25	0.32	0.40	0.49	0.58	0.68	0.78	0.89	0.008	0.029	0.042	0.064	
5900	0.14	0.20	0.26	0.33	0.40	0.49	0.59	0.69	0.79	0.90	0.008	0.029	0.042	0.065	
6000	0.14	0.20	0.26	0.33	0.41	0.50	0.60	0.70	0.80	0.91	0.008	0.030	0.043	0.067	
⑩															
⑮															
Statically balanced											v [m/s]				
Statically balanced											Pulleys				

POWER RATINGS

optibelt VB PROFILE 8

NOMINAL POWER RATING P_N [kW] FOR $\beta = 180^\circ$ AND $L_d = 579$ mm

Table 48

Pulleys	v [m/s]	n_k [min ⁻¹]	Datum diameter of small pulley d_{dk} [mm]								Additional power [kW] per belt for speed ratio i				
			35	40	45	50	56	63	71	80	90	1.01 to 1.05	1.06 to 1.26	1.27 to 1.57	> 1.57
Statically balanced	②	700	0.12	0.15	0.18	0.21	0.25	0.29	0.34	0.39	0.45	0.00	0.01	0.01	0.01
		950	0.15	0.19	0.23	0.27	0.32	0.37	0.43	0.50	0.57	0.00	0.01	0.02	0.02
		1450	0.19	0.25	0.31	0.37	0.43	0.51	0.59	0.69	0.79	0.00	0.02	0.03	0.03
		2850	0.28	0.38	0.48	0.57	0.69	0.81	0.95	1.11	1.27	0.01	0.03	0.05	0.06
		100	0.03	0.03	0.04	0.04	0.05	0.06	0.07	0.08	0.09	0.00	0.00	0.00	0.00
		200	0.05	0.06	0.07	0.08	0.09	0.11	0.12	0.14	0.16	0.00	0.00	0.00	0.00
		300	0.06	0.08	0.09	0.11	0.13	0.15	0.17	0.20	0.23	0.00	0.00	0.01	0.01
		400	0.08	0.10	0.12	0.14	0.16	0.19	0.22	0.25	0.28	0.00	0.00	0.01	0.01
		500	0.09	0.12	0.14	0.16	0.19	0.22	0.26	0.30	0.34	0.00	0.01	0.01	0.01
		600	0.11	0.13	0.16	0.19	0.22	0.26	0.30	0.35	0.40	0.00	0.01	0.01	0.01
		700	0.12	0.15	0.18	0.21	0.25	0.29	0.34	0.39	0.45	0.00	0.01	0.01	0.01
		800	0.13	0.17	0.20	0.24	0.28	0.32	0.38	0.43	0.50	0.00	0.01	0.01	0.02
		900	0.14	0.18	0.22	0.26	0.30	0.35	0.41	0.48	0.55	0.00	0.01	0.02	0.02
		1000	0.15	0.19	0.24	0.28	0.33	0.38	0.45	0.52	0.59	0.00	0.01	0.02	0.02
		1100	0.16	0.21	0.25	0.30	0.35	0.41	0.48	0.56	0.64	0.00	0.01	0.02	0.02
		1200	0.17	0.22	0.27	0.32	0.38	0.44	0.51	0.59	0.68	0.00	0.01	0.02	0.02
		1300	0.18	0.23	0.29	0.34	0.40	0.47	0.55	0.63	0.72	0.00	0.02	0.02	0.03
		1400	0.19	0.24	0.30	0.36	0.42	0.49	0.58	0.67	0.77	0.00	0.02	0.03	0.03
		1500	0.20	0.26	0.32	0.37	0.44	0.52	0.61	0.70	0.81	0.00	0.02	0.03	0.03
		1600	0.20	0.27	0.33	0.39	0.46	0.55	0.64	0.74	0.85	0.00	0.02	0.03	0.03
		1700	0.21	0.28	0.34	0.41	0.48	0.57	0.67	0.77	0.88	0.00	0.02	0.03	0.04
		1800	0.22	0.29	0.36	0.42	0.50	0.59	0.69	0.80	0.92	0.00	0.02	0.03	0.04
		1900	0.22	0.30	0.37	0.44	0.52	0.62	0.72	0.84	0.96	0.00	0.02	0.04	0.04
		2000	0.23	0.31	0.38	0.46	0.54	0.64	0.75	0.87	0.99	0.00	0.02	0.04	0.04
		2100	0.24	0.32	0.40	0.47	0.56	0.66	0.77	0.90	1.03	0.00	0.02	0.04	0.04
		2200	0.24	0.33	0.41	0.49	0.58	0.68	0.80	0.93	1.06	0.01	0.03	0.04	0.05
		2300	0.25	0.34	0.42	0.50	0.60	0.70	0.83	0.96	1.10	0.01	0.03	0.04	0.05
		2400	0.25	0.34	0.43	0.51	0.61	0.73	0.85	0.98	1.13	0.01	0.03	0.04	0.05
		2500	0.26	0.35	0.44	0.53	0.63	0.75	0.87	1.01	1.16	0.01	0.03	0.05	0.05
		2600	0.27	0.36	0.45	0.54	0.65	0.77	0.90	1.04	1.19	0.01	0.03	0.05	0.05
		2700	0.27	0.37	0.46	0.56	0.66	0.79	0.92	1.07	1.22	0.01	0.03	0.05	0.06
		2800	0.27	0.38	0.47	0.57	0.68	0.80	0.94	1.09	1.25	0.01	0.03	0.05	0.06
		2900	0.28	0.38	0.48	0.58	0.69	0.82	0.96	1.12	1.28	0.01	0.03	0.05	0.06
		3000	0.28	0.39	0.49	0.59	0.71	0.84	0.99	1.14	1.31	0.01	0.03	0.06	0.06
		3100	0.29	0.40	0.50	0.60	0.72	0.86	1.01	1.17	1.34	0.01	0.04	0.06	0.06
		3200	0.29	0.40	0.51	0.62	0.74	0.88	1.03	1.19	1.36	0.01	0.04	0.06	0.07
		3300	0.30	0.41	0.52	0.63	0.75	0.89	1.05	1.21	1.39	0.01	0.04	0.06	0.07
		3400	0.30	0.42	0.53	0.64	0.77	0.91	1.07	1.24	1.41	0.01	0.04	0.06	0.07
		3500	0.30	0.42	0.54	0.65	0.78	0.93	1.09	1.26	1.44	0.01	0.04	0.06	0.07
		3600	0.31	0.43	0.55	0.66	0.79	0.94	1.10	1.28	1.46	0.01	0.04	0.07	0.07
		3700	0.31	0.43	0.55	0.67	0.81	0.96	1.12	1.30	1.49	0.01	0.04	0.07	0.08
		3800	0.31	0.44	0.56	0.68	0.82	0.97	1.14	1.32	1.51	0.01	0.04	0.07	0.08
		3900	0.31	0.44	0.57	0.69	0.83	0.99	1.16	1.34	1.53	0.01	0.05	0.07	0.08
		4000	0.32	0.45	0.58	0.70	0.84	1.00	1.17	1.36	1.55	0.01	0.05	0.07	0.08
		4100	0.32	0.45	0.58	0.71	0.85	1.02	1.19	1.38	1.57	0.01	0.05	0.08	0.09
		4200	0.32	0.46	0.59	0.72	0.86	1.03	1.21	1.40	1.59	0.01	0.05	0.08	0.09
		4300	0.32	0.46	0.60	0.73	0.88	1.04	1.22	1.41	1.61	0.01	0.05	0.08	0.09
		4400	0.33	0.47	0.60	0.73	0.89	1.06	1.24	1.43	1.63	0.01	0.05	0.08	0.09
		4500	0.33	0.47	0.61	0.74	0.90	1.07	1.25	1.45	1.65	0.01	0.05	0.08	0.09
		4600	0.33	0.48	0.62	0.75	0.91	1.08	1.27	1.46	1.66	0.01	0.05	0.09	0.10
		4700	0.33	0.48	0.62	0.76	0.92	1.09	1.28	1.48	1.68	0.01	0.05	0.09	0.10
		4800	0.33	0.48	0.63	0.77	0.93	1.10	1.29	1.49	1.69	0.01	0.06	0.09	0.10
		4900	0.33	0.49	0.63	0.77	0.94	1.11	1.31	1.51	1.71	0.01	0.06	0.09	0.10
		5000	0.34	0.49	0.64	0.78	0.94	1.13	1.32	1.52	1.72	0.01	0.06	0.09	0.10
		5100	0.34	0.49	0.64	0.79	0.95	1.14	1.33	1.53	1.74	0.01	0.06	0.09	0.11
		5200	0.34	0.50	0.65	0.79	0.96	1.15	1.34	1.55	1.75	0.01	0.06	0.10	0.11
		5300	0.34	0.50	0.65	0.80	0.97	1.16	1.35	1.56	1.76	0.01	0.06	0.10	0.11
		5400	0.34	0.50	0.66	0.81	0.98	1.17	1.36	1.57	1.77	0.01	0.06	0.10	0.11
		5500	0.34	0.51	0.66	0.81	0.99	1.17	1.38	1.58	1.78	0.01	0.06	0.10	0.11
		5600	0.34	0.51	0.67	0.82	0.99	1.18	1.38	1.59	1.79	0.01	0.06	0.10	0.12
		5700	0.34	0.51	0.67	0.83	1.00	1.19	1.39	1.60	1.80	0.01	0.07	0.11	0.12
		5800	0.34	0.51	0.68	0.83	1.01	1.20	1.40	1.61	1.81	0.01	0.07	0.11	0.12
		5900	0.34	0.51	0.68	0.84	1.01	1.21	1.41	1.62	1.82	0.01	0.07	0.11	0.12
		6000	0.34	0.52	0.68	0.84	1.02	1.22	1.42	1.63	1.82	0.01	0.07	0.11	0.12
		6200	0.34	0.52	0.69	0.85	1.03	1.23	1.43	1.64	1.83	0.01	0.07	0.11	0.13
		6400	0.34	0.52	0.69	0.86	1.04	1.24	1.45	1.65	1.84	0.01	0.07	0.12	0.13
		6600	0.34	0.52	0.70	0.87	1.05	1.25	1.46	1.66	1.84	0.02	0.08	0.12	0.14
		6800	0.34	0.53	0.70	0.87	1.06	1.26	1.47	1.67	1.84	0.02	0.08	0.13	0.14
		7000	0.34	0.53	0.71	0.88	1.07	1.27	1.48	1.67	1.84	0.02	0.08	0.13	0.15
		7200	0.33	0.53	0.71	0.88	1.07	1.28	1.48	1.67	1.84	0.02	0.08	0.13	0.15
		7400	0.33	0.53	0.71	0.89	1.08	1.28	1.48	1.67	1.83	0.02	0.09	0.14	0.15
		7600	0.33	0.53	0.72	0.89	1.08	1.29	1.49	1.67	1.81	0.02	0.09	0.14	0.16
		7800	0.32	0.53	0.72	0.89	1.09	1.29	1.49	1.66	1.80	0.02	0.09	0.14	0.16
		8000	0.32	0.52	0.72	0.89	1.09	1.29	1.48	1.65	1.78	0.02	0.09	0.15	0.17
					⑮	⑳	㉑	㉒	⑳			v [m/s]			
												Dynamically balanced			Pulleys

POWER RATINGS

optibelt VB PROFILE Z/10

NOMINAL POWER RATING P_N [kW] FOR $\beta = 180^\circ$ AND $L_d = 822$ mm

Table 49

Pulleys	v [m/s]	n_k [min ⁻¹]	Datum diameter of small pulley d_{dk} [mm]								Additional power [kW] per belt for speed ratio i				
			45	50	56	63	71	80	90	100	112	1.01 to 1.05	1.06 to 1.26	1.27 to 1.57	> 1.57
Statically balanced	②	700	0.18	0.22	0.28	0.34	0.42	0.50	0.59	0.67	0.77	0.00	0.02	0.03	0.03
		950	0.22	0.28	0.35	0.44	0.53	0.64	0.75	0.86	1.00	0.00	0.02	0.04	0.04
		1450	0.29	0.38	0.48	0.60	0.74	0.89	1.06	1.22	1.40	0.01	0.03	0.06	0.06
	2850	0.42	0.58	0.77	0.98	1.22	1.47	1.75	2.02	2.33	0.01	0.07	0.11	0.12	
	100	0.04	0.05	0.06	0.07	0.08	0.10	0.11	0.13	0.15	0.00	0.00	0.00	0.00	
	200	0.07	0.08	0.10	0.12	0.15	0.17	0.20	0.23	0.27	0.00	0.00	0.01	0.01	
	300	0.09	0.12	0.14	0.17	0.21	0.25	0.29	0.33	0.38	0.00	0.01	0.01	0.01	
	400	0.12	0.15	0.18	0.22	0.26	0.31	0.37	0.42	0.48	0.00	0.01	0.02	0.02	
	500	0.14	0.17	0.21	0.26	0.32	0.38	0.44	0.51	0.58	0.00	0.01	0.02	0.02	
	600	0.16	0.20	0.25	0.30	0.37	0.44	0.51	0.59	0.68	0.00	0.01	0.02	0.03	
	700	0.18	0.22	0.28	0.34	0.42	0.50	0.59	0.67	0.77	0.00	0.02	0.03	0.03	
	800	0.19	0.25	0.31	0.38	0.46	0.55	0.65	0.75	0.87	0.00	0.02	0.03	0.03	
	900	0.21	0.27	0.34	0.42	0.51	0.61	0.72	0.83	0.95	0.00	0.02	0.03	0.04	
	1000	0.23	0.29	0.37	0.45	0.55	0.66	0.78	0.90	1.04	0.00	0.02	0.04	0.04	
	1100	0.24	0.31	0.39	0.49	0.60	0.72	0.85	0.97	1.12	0.01	0.03	0.04	0.05	
	1200	0.25	0.33	0.42	0.52	0.64	0.77	0.91	1.05	1.21	0.01	0.03	0.05	0.05	
	1300	0.27	0.35	0.45	0.56	0.68	0.82	0.97	1.11	1.29	0.01	0.03	0.05	0.06	
	1400	0.28	0.37	0.47	0.59	0.72	0.87	1.03	1.18	1.37	0.01	0.03	0.05	0.06	
	1500	0.29	0.39	0.49	0.62	0.76	0.91	1.08	1.25	1.44	0.01	0.04	0.06	0.06	
	1600	0.31	0.40	0.52	0.65	0.80	0.96	1.14	1.31	1.52	0.01	0.04	0.06	0.07	
	1700	0.32	0.42	0.54	0.68	0.84	1.01	1.19	1.38	1.59	0.01	0.04	0.07	0.07	
	1800	0.33	0.44	0.56	0.71	0.87	1.05	1.25	1.44	1.66	0.01	0.04	0.07	0.08	
	1900	0.34	0.45	0.59	0.74	0.91	1.10	1.30	1.50	1.73	0.01	0.05	0.07	0.08	
	2000	0.35	0.47	0.61	0.77	0.94	1.14	1.35	1.56	1.80	0.01	0.05	0.08	0.09	
	2100	0.36	0.48	0.63	0.79	0.98	1.18	1.40	1.62	1.87	0.01	0.05	0.08	0.09	
	2200	0.37	0.50	0.65	0.82	1.01	1.22	1.45	1.68	1.94	0.01	0.05	0.08	0.10	
	2300	0.38	0.51	0.67	0.85	1.05	1.26	1.50	1.73	2.00	0.01	0.06	0.09	0.10	
	2400	0.39	0.52	0.69	0.87	1.08	1.30	1.55	1.79	2.06	0.01	0.06	0.09	0.10	
	2500	0.39	0.54	0.70	0.90	1.11	1.34	1.60	1.84	2.12	0.01	0.06	0.10	0.11	
	2600	0.40	0.55	0.72	0.92	1.14	1.38	1.64	1.89	2.18	0.01	0.06	0.10	0.11	
	2700	0.41	0.56	0.74	0.94	1.17	1.42	1.69	1.94	2.24	0.01	0.06	0.10	0.12	
	2800	0.42	0.57	0.76	0.97	1.20	1.46	1.73	1.99	2.30	0.01	0.07	0.11	0.12	
	2900	0.42	0.59	0.77	0.99	1.23	1.49	1.77	2.04	2.35	0.01	0.07	0.11	0.13	
	3000	0.43	0.60	0.79	1.01	1.26	1.53	1.81	2.09	2.41	0.01	0.07	0.12	0.13	
	3100	0.44	0.61	0.81	1.03	1.29	1.56	1.85	2.14	2.46	0.01	0.07	0.12	0.13	
	3200	0.44	0.62	0.82	1.06	1.31	1.59	1.89	2.18	2.51	0.02	0.08	0.12	0.14	
	3300	0.45	0.63	0.84	1.08	1.34	1.63	1.93	2.22	2.56	0.02	0.08	0.13	0.14	
	3400	0.46	0.64	0.85	1.10	1.37	1.66	1.97	2.27	2.60	0.02	0.08	0.13	0.15	
	3500	0.46	0.65	0.87	1.12	1.39	1.69	2.01	2.31	2.65	0.02	0.08	0.13	0.15	
	3600	0.47	0.66	0.88	1.14	1.42	1.72	2.04	2.35	2.69	0.02	0.09	0.14	0.16	
	3700	0.47	0.67	0.90	1.15	1.44	1.75	2.08	2.39	2.74	0.02	0.09	0.14	0.16	
	3800	0.48	0.68	0.91	1.17	1.46	1.78	2.11	2.42	2.78	0.02	0.09	0.15	0.16	
	3900	0.48	0.68	0.92	1.19	1.49	1.81	2.14	2.46	2.81	0.02	0.09	0.15	0.17	
	4000	0.48	0.69	0.93	1.21	1.51	1.83	2.17	2.49	2.85	0.02	0.10	0.15	0.17	
	4100	0.49	0.70	0.95	1.22	1.53	1.86	2.20	2.53	2.89	0.02	0.10	0.16	0.18	
	4200	0.49	0.71	0.96	1.24	1.55	1.89	2.23	2.56	2.92	0.02	0.10	0.16	0.18	
	4300	0.49	0.71	0.97	1.26	1.57	1.91	2.26	2.59	2.95	0.02	0.10	0.17	0.19	
	4400	0.50	0.72	0.98	1.27	1.59	1.93	2.29	2.62	2.98	0.02	0.11	0.17	0.19	
	4500	0.50	0.73	0.99	1.29	1.61	1.96	2.32	2.65	3.01	0.02	0.11	0.17	0.19	
	4600	0.50	0.73	1.00	1.30	1.63	1.98	2.34	2.67	3.04	0.02	0.11	0.18	0.20	
	4700	0.50	0.74	1.01	1.32	1.65	2.00	2.37	2.70	3.06	0.02	0.11	0.18	0.20	
	4800	0.51	0.74	1.02	1.33	1.67	2.02	2.39	2.72	3.08	0.02	0.12	0.18	0.21	
	4900	0.51	0.75	1.03	1.34	1.68	2.04	2.41	2.75	3.10	0.02	0.12	0.19	0.21	
	5000	0.51	0.75	1.04	1.35	1.70	2.06	2.43	2.77	3.12	0.02	0.12	0.19	0.22	
	5100	0.51	0.76	1.05	1.37	1.71	2.08	2.45	2.79	3.14	0.02	0.12	0.20	0.22	
	5200	0.51	0.76	1.05	1.38	1.73	2.10	2.47	2.80	3.15	0.03	0.13	0.20	0.23	
	5300	0.51	0.77	1.06	1.39	1.74	2.11	2.49	2.82	3.16	0.03	0.13	0.20	0.23	
	5400	0.51	0.77	1.07	1.40	1.76	2.13	2.50	2.83	3.17	0.03	0.13	0.21	0.23	
	5500	0.51	0.77	1.08	1.41	1.77	2.14	2.52	2.85	3.18	0.03	0.13	0.21	0.24	
	5600	0.51	0.78	1.08	1.42	1.78	2.16	2.53	2.86	3.19	0.03	0.13	0.22	0.24	
	5800	0.51	0.78	1.09	1.44	1.80	2.18	2.56	2.88	3.19	0.03	0.14	0.22	0.25	
	6000	0.51	0.79	1.10	1.45	1.82	2.20	2.57	2.89	3.19	0.03	0.14	0.23	0.26	
	6200	0.51	0.79	1.11	1.47	1.84	2.22	2.59	2.90	3.18	0.03	0.15	0.24	0.27	
	6400	0.50	0.79	1.12	1.48	1.85	2.23	2.60	2.89	3.15	0.03	0.15	0.25	0.28	
	6600	0.50	0.79	1.12	1.49	1.86	2.24	2.60	2.88	3.12	0.03	0.16	0.25	0.29	
	6800	0.49	0.79	1.13	1.49	1.87	2.25	2.60	2.87	3.08	0.03	0.16	0.26	0.29	
	7000	0.49	0.79	1.13	1.50	1.88	2.25	2.59	2.85	3.03	0.03	0.17	0.27	0.30	
	7200	0.48	0.78	1.13	1.50	1.88	2.25	2.58	2.82	2.97	0.03	0.17	0.28	0.31	
	7400	0.47	0.78	1.13	1.50	1.88	2.24	2.56	2.78	2.90	0.04	0.18	0.28	0.32	
	7600	0.46	0.77	1.12	1.50	1.88	2.23	2.53			0.04	0.18	0.29	0.33	
	7800	0.45	0.77	1.12	1.49	1.87	2.22	2.50			0.04	0.19	0.30	0.34	
	8000	0.44	0.76	1.11	1.49	1.86	2.20	2.47			0.04	0.19	0.31	0.35	
	8200	0.42	0.75	1.11	1.48	1.85	2.17				0.04	0.20	0.32	0.35	
	8400	0.41	0.74	1.10	1.47	1.83	2.15				0.04	0.20	0.32	0.36	
				②⑤	③⑤	③⑤									
															v [m/s]
															Pulleys

v > 30 m/s. Please consult our Application Engineering Department.

POWER RATINGS

optibelt VB PROFILE B/17

NOMINAL POWER RATING P_N [kW] FOR $\beta = 180^\circ$ AND $L_d = 2280$ mm

Table 51

Pulleys	v [m/s]	n_k [min ⁻¹]	Datum diameter of small pulley d_{jk} [mm]														Additional power [kW] per belt for speed ratio i				
			112	125	132	140	150	160	170	180	190	200	212	224	236	250	280	1.01 to 1.05	1.06 to 1.26	1.27 to 1.57	> 1.57
Statically balanced		700	1.49	1.96	2.21	2.50	2.85	3.20	3.55	3.89	4.24	4.58	4.98	5.38	5.78	6.23	7.19	0.03	0.17	0.27	0.30
		950	1.83	2.45	2.77	3.15	3.61	4.06	4.51	4.96	5.40	5.83	6.35	6.86	7.36	7.94	9.14	0.05	0.23	0.37	0.41
		1450	2.37	3.25	3.72	4.24	4.89	5.52	6.14	6.75	7.35	7.94	8.63	9.31	9.96	10.70	12.20	0.07	0.35	0.56	0.63
		2850	2.99	4.37	5.08	5.87	6.80	7.67	8.49	9.24	9.93	10.56	11.22	11.78	12.24	12.62	12.90	0.14	0.69	1.10	1.24
		100	0.33	0.41	0.46	0.51	0.57	0.63	0.69	0.75	0.81	0.87	0.94	1.01	1.08	1.17	1.34	0.00	0.02	0.04	0.04
		200	0.58	0.73	0.81	0.91	1.02	1.14	1.25	1.37	1.48	1.59	1.73	1.86	1.99	2.15	2.47	0.01	0.05	0.08	0.09
		300	0.79	1.01	1.13	1.27	1.43	1.60	1.77	1.93	2.09	2.25	2.45	2.64	2.83	3.05	3.52	0.01	0.07	0.12	0.13
		400	0.99	1.27	1.43	1.60	1.82	2.03	2.25	2.46	2.67	2.88	3.13	3.37	3.62	3.91	4.51	0.02	0.10	0.15	0.17
		500	1.17	1.52	1.70	1.92	2.18	2.44	2.70	2.96	3.22	3.47	3.77	4.07	4.37	4.72	5.45	0.02	0.12	0.19	0.22
		600	1.33	1.74	1.96	2.21	2.52	2.83	3.13	3.44	3.74	4.03	4.39	4.74	5.09	5.49	6.34	0.03	0.14	0.23	0.26
		700	1.49	1.96	2.21	2.50	2.85	3.20	3.55	3.89	4.24	4.58	4.98	5.38	5.78	6.23	7.19	0.03	0.17	0.27	0.30
		800	1.63	2.16	2.44	2.77	3.16	3.56	3.95	4.33	4.72	5.09	5.55	5.99	6.43	6.94	8.00	0.04	0.19	0.31	0.35
		900	1.77	2.35	2.67	3.02	3.46	3.90	4.33	4.75	5.17	5.59	6.09	6.57	7.06	7.61	8.77	0.04	0.22	0.35	0.39
		1000	1.89	2.54	2.88	3.27	3.75	4.22	4.69	5.16	5.61	6.07	6.60	7.13	7.65	8.25	9.50	0.05	0.24	0.39	0.43
		1100	2.01	2.71	3.08	3.50	4.02	4.53	5.04	5.54	6.03	6.52	7.10	7.66	8.22	8.86	10.18	0.05	0.27	0.42	0.48
		1200	2.12	2.88	3.28	3.73	4.28	4.83	5.37	5.91	6.44	6.95	7.57	8.17	8.76	9.43	10.82	0.06	0.29	0.46	0.52
		1300	2.23	3.03	3.46	3.94	4.53	5.12	5.69	6.26	6.82	7.37	8.01	8.64	9.26	9.97	11.41	0.06	0.31	0.50	0.56
		1400	2.33	3.18	3.63	4.14	4.77	5.39	6.00	6.59	7.18	7.76	8.43	9.09	9.74	10.47	11.95	0.07	0.34	0.54	0.61
		1500	2.42	3.32	3.80	4.33	5.00	5.65	6.28	6.91	7.52	8.12	8.83	9.51	10.18	10.93	12.44	0.07	0.36	0.58	0.65
		1600	2.50	3.45	3.95	4.52	5.21	5.89	6.56	7.21	7.85	8.47	9.20	9.90	10.58	11.35	12.88	0.08	0.39	0.62	0.69
		1700	2.58	3.57	4.10	4.69	5.41	6.12	6.81	7.49	8.15	8.79	9.54	10.26	10.95	11.73	13.26	0.08	0.41	0.66	0.74
		1800	2.65	3.69	4.24	4.85	5.60	6.34	7.05	7.75	8.43	9.09	9.85	10.58	11.29	12.07	13.59	0.09	0.43	0.70	0.78
		1900	2.72	3.79	4.36	5.00	5.78	6.54	7.27	7.99	8.69	9.36	10.14	10.88	11.58	12.36	13.85	0.09	0.46	0.73	0.82
		2000	2.77	3.89	4.48	5.14	5.94	6.72	7.48	8.21	8.92	9.61	10.39	11.14	11.84	12.61	14.06	0.10	0.48	0.77	0.87
		2100	2.82	3.98	4.59	5.27	6.09	6.90	7.67	8.42	9.14	9.83	10.62	11.36	12.06	12.81	14.19	0.10	0.51	0.81	0.91
		2200	2.87	4.06	4.69	5.39	6.23	7.05	7.84	8.60	9.33	10.02	10.81	11.55	12.23	12.96	14.26	0.11	0.53	0.85	0.96
		2300	2.91	4.14	4.78	5.49	6.36	7.19	7.99	8.76	9.49	10.19	10.97	11.70	12.36	13.06	14.26	0.11	0.56	0.89	1.00
		2400	2.94	4.20	4.86	5.59	6.47	7.32	8.13	8.90	9.63	10.32	11.10	11.81	12.45	13.11	14.19	0.12	0.58	0.93	1.04
		2500	2.96	4.25	4.93	5.67	6.57	7.43	8.24	9.02	9.75	10.43	11.19	11.88	12.49	13.10	14.04	0.12	0.60	0.97	1.09
		2600	2.98	4.30	4.98	5.74	6.65	7.52	8.34	9.11	9.83	10.51	11.25	11.90	12.48			0.13	0.63	1.00	1.13
		2700	2.99	4.34	5.03	5.80	6.72	7.59	8.41	9.18	9.90	10.55	11.27	11.89	12.42			0.13	0.65	1.04	1.17
		2800	2.99	4.36	5.07	5.85	6.77	7.65	8.47	9.23	9.93	10.57	11.25	11.83	12.31			0.14	0.68	1.08	1.22
		2900	2.98	4.38	5.10	5.88	6.81	7.69	8.50	9.25	9.93	10.55	11.19	11.73	12.15			0.14	0.70	1.12	1.26
		3000	2.97	4.39	5.11	5.90	6.84	7.71	8.51	9.25	9.91	10.49	11.09	11.58	11.93			0.14	0.72	1.16	1.30
		3100	2.95	4.39	5.12	5.91	6.84	7.71	8.50	9.22	9.85	10.41						0.15	0.75	1.20	1.35
		3200	2.92	4.37	5.11	5.90	6.83	7.69	8.47	9.16	9.77	10.28						0.15	0.77	1.24	1.39
		3300	2.89	4.35	5.09	5.88	6.81	7.65	8.41	9.08	9.65	10.12						0.16	0.80	1.27	1.43
		3400	2.85	4.32	5.06	5.85	6.77	7.59	8.33	8.96	9.50	9.92						0.16	0.82	1.31	1.48
		3500	2.80	4.27	5.01	5.80	6.71	7.52	8.22	8.82	9.31	9.68						0.17	0.84	1.35	1.52
		3600	2.74	4.22	4.96	5.74	6.63	7.41	8.09									0.17	0.87	1.39	1.56
		3700	2.67	4.15	4.89	5.66	6.53	7.29	7.93									0.18	0.89	1.43	1.61
		3800	2.59	4.08	4.80	5.57	6.42	7.15	7.75									0.18	0.92	1.47	1.65
		3900	2.51	3.99	4.71	5.46	6.29	6.98	7.54									0.19	0.94	1.51	1.69
		4000	2.42	3.89	4.60	5.34	6.13	6.79	7.31									0.19	0.97	1.55	1.74
		4100	2.31	3.78	4.48	5.19	5.96											0.20	0.99	1.58	1.78
		4200	2.20	3.65	4.34	5.04	5.77											0.20	1.01	1.62	1.82
		4300	2.08	3.52	4.19	4.86	5.56											0.21	1.04	1.66	1.87
		4400	1.95	3.37	4.02	4.67	5.32											0.21	1.06	1.70	1.91
		4500	1.82	3.21	3.84	4.46	5.07											0.22	1.09	1.74	1.95
		4600	1.67	3.03	3.65													0.22	1.11	1.78	2.00
4700	1.51	2.85	3.44													0.23	1.13	1.82	2.04		
4800	1.34	2.65	3.21													0.23	1.16	1.85	2.08		
4900	1.16	2.43	2.97													0.24	1.18	1.89	2.13		
5000	0.97	2.20	2.71													0.24	1.21	1.93	2.17		

v > 30 m/s.
Please consult our
Application Engineering
Department.

(30)

v [m/s]

Dynamically balanced (for details see DIN 2211)

Pulleys

POWER RATINGS

optibelt **VB PROFILE C/22**

NOMINAL POWER RATING P_N [kW] FOR $\beta = 180^\circ$ AND $L_d = 3808$ mm

Table 52

Pulleys	v [m/s]	n_k [min ⁻¹]	Datum diameter of small pulley d_{dk} [mm]														Additional power [kW] per belt for speed ratio i				
			180	200	212	224	236	250	265	280	300	315	335	355	375	400	450	1.01 to 1.05	1.06 to 1.26	1.27 to 1.57	> 1.57
Statically balanced		700	4.51	5.66	6.35	7.02	7.69	8.47	9.28	10.09	11.16	11.94	12.98	14.00	15.00	16.22	18.58	0.08	0.40	0.63	0.71
		950	5.60	7.08	7.95	8.81	9.67	10.64	11.67	12.69	14.01	14.98	16.24	17.47	18.66	20.10	22.79	0.11	0.54	0.86	0.97
		1450	7.23	9.24	10.42	11.56	12.67	13.93	15.24	16.49	18.08	19.20	20.62	21.93	23.13	24.46	26.56	0.16	0.82	1.31	1.48
		2850	7.54	9.81	10.94	11.91	12.69	13.37	13.79	13.88	13.47	12.74						0.32	1.61	2.58	2.90
		50	0.53	0.64	0.70	0.76	0.83	0.90	0.98	1.06	1.16	1.24	1.34	1.44	1.54	1.67	1.92	0.01	0.03	0.05	0.05
		100	0.95	1.16	1.28	1.39	1.51	1.65	1.80	1.95	2.14	2.28	2.48	2.67	2.86	3.09	3.56	0.01	0.06	0.09	0.10
		150	1.34	1.63	1.80	1.97	2.15	2.35	2.56	2.77	3.05	3.26	3.54	3.81	4.09	4.43	5.10	0.02	0.08	0.14	0.15
		200	1.69	2.07	2.30	2.52	2.75	3.00	3.28	3.55	3.92	4.19	4.55	4.91	5.26	5.70	6.57	0.02	0.11	0.18	0.20
		250	2.03	2.49	2.77	3.04	3.32	3.63	3.97	4.31	4.75	5.08	5.52	5.95	6.39	6.92	7.98	0.03	0.14	0.23	0.25
		300	2.35	2.90	3.22	3.54	3.87	4.24	4.64	5.03	5.55	5.94	6.45	6.97	7.47	8.10	9.34	0.03	0.17	0.27	0.31
		350	2.66	3.28	3.66	4.03	4.40	4.82	5.28	5.73	6.33	6.77	7.36	7.94	8.52	9.24	10.66	0.04	0.20	0.32	0.36
		400	2.95	3.66	4.08	4.49	4.91	5.39	5.90	6.41	7.08	7.58	8.24	8.89	9.54	10.34	11.92	0.05	0.23	0.36	0.41
		450	3.23	4.02	4.48	4.95	5.41	5.94	6.51	7.07	7.81	8.36	9.09	9.81	10.53	11.41	13.14	0.05	0.25	0.41	0.46
		500	3.51	4.37	4.88	5.39	5.89	6.47	7.09	7.71	8.52	9.12	9.92	10.70	11.48	12.44	14.32	0.06	0.28	0.45	0.51
		550	3.77	4.71	5.26	5.81	6.36	6.99	7.67	8.33	9.21	9.86	10.72	11.57	12.41	13.44	15.46	0.06	0.31	0.50	0.56
		600	4.03	5.04	5.63	6.23	6.82	7.50	8.22	8.94	9.88	10.58	11.50	12.41	13.30	14.40	16.55	0.07	0.34	0.54	0.61
		650	4.27	5.36	6.00	6.63	7.26	7.99	8.76	9.52	10.53	11.27	12.25	13.21	14.16	15.33	17.59	0.07	0.37	0.59	0.66
		700	4.51	5.66	6.35	7.02	7.69	8.47	9.28	10.09	11.16	11.94	12.98	14.00	15.00	16.22	18.58	0.08	0.40	0.63	0.71
		750	4.74	5.97	6.69	7.40	8.11	8.93	9.79	10.65	11.77	12.60	13.68	14.75	15.80	17.07	19.53	0.08	0.42	0.68	0.76
		800	4.97	6.26	7.02	7.77	8.52	9.38	10.29	11.18	12.36	13.23	14.36	15.47	16.56	17.89	20.42	0.09	0.45	0.72	0.81
		850	5.18	6.54	7.34	8.13	8.91	9.81	10.76	11.70	12.93	13.83	15.01	16.17	17.30	18.67	21.27	0.10	0.48	0.77	0.87
		900	5.39	6.81	7.65	8.48	9.29	10.24	11.23	12.20	13.48	14.42	15.64	16.83	18.00	19.40	22.05	0.10	0.51	0.81	0.92
		950	5.60	7.08	7.95	8.81	9.67	10.64	11.67	12.69	14.01	14.98	16.24	17.47	18.66	20.10	22.79	0.11	0.54	0.86	0.97
		1000	5.79	7.33	8.24	9.14	10.02	11.04	12.11	13.15	14.52	15.52	16.81	18.07	19.29	20.75	23.46	0.11	0.57	0.91	1.02
		1050	5.98	7.58	8.52	9.45	10.37	11.42	12.52	13.60	15.01	16.03	17.36	18.64	19.88	21.36	24.07	0.12	0.59	0.95	1.07
		1100	6.16	7.82	8.80	9.76	10.70	11.79	12.92	14.03	15.47	16.52	17.87	19.18	20.43	21.92	24.62	0.12	0.62	1.00	1.12
		1150	6.33	8.05	9.06	10.05	11.02	12.14	13.30	14.44	15.91	16.98	18.36	19.68	20.94	22.43	25.11	0.13	0.65	1.04	1.17
		1200	6.50	8.27	9.31	10.33	11.33	12.47	13.67	14.83	16.34	17.42	18.82	20.15	21.42	22.90	25.53	0.14	0.68	1.09	1.22
		1250	6.66	8.48	9.55	10.60	11.63	12.80	14.02	15.21	16.73	17.83	19.24	20.58	21.85	23.32	25.88	0.14	0.71	1.13	1.27
		1300	6.81	8.69	9.78	10.86	11.91	13.10	14.35	15.56	17.11	18.22	19.64	20.98	22.23	23.69	26.17	0.15	0.74	1.18	1.32
1350	6.96	8.88	10.00	11.10	12.18	13.40	14.66	15.89	17.46	18.58	20.00	21.33	22.58	24.00	26.37	0.15	0.76	1.22	1.37		
1400	7.09	9.07	10.22	11.34	12.43	13.67	14.96	16.20	17.78	18.91	20.33	21.65	22.87	24.26	26.51	0.16	0.79	1.27	1.42		
1450	7.23	9.24	10.42	11.56	12.67	13.93	15.24	16.49	18.08	19.20	20.62	21.93	23.13	24.46	26.56	0.16	0.82	1.31	1.48		
1500	7.35	9.41	10.60	11.77	12.90	14.18	15.50	16.76	18.35	19.47	20.88	22.16	23.33	24.61	26.54	0.17	0.85	1.36	1.53		
1550	7.46	9.57	10.78	11.97	13.11	14.41	15.73	17.00	18.60	19.71	21.10	22.36	23.48	24.70	26.43	0.18	0.88	1.40	1.58		
1600	7.57	9.71	10.95	12.15	13.31	14.62	15.95	17.23	18.81	19.92	21.28	22.51	23.59	24.72	26.24	0.18	0.91	1.45	1.63		
1650	7.67	9.85	11.11	12.32	13.49	14.81	16.15	17.42	19.00	20.10	21.43	22.61	23.64	24.69	25.96	0.19	0.93	1.49	1.68		
1700	7.77	9.98	11.25	12.48	13.66	14.99	16.33	17.60	19.17	20.24	21.54	22.67	23.64	24.59	25.59	0.19	0.96	1.54	1.73		
1750	7.85	10.10	11.38	12.62	13.82	15.14	16.49	17.75	19.30	20.35	21.61	22.69	23.58	24.42	25.13	0.20	0.99	1.58	1.78		
1800	7.93	10.20	11.50	12.75	13.95	15.28	16.63	17.88	19.40	20.43	21.64	22.65				0.20	1.02	1.63	1.83		
1850	8.00	10.30	11.61	12.87	14.07	15.41	16.74	17.98	19.47	20.47	21.62	22.57				0.21	1.05	1.67	1.88		
1900	8.06	10.39	11.71	12.97	14.18	15.51	16.83	18.06	19.51	20.47	21.57	22.44				0.22	1.07	1.72	1.93		
1950	8.12	10.46	11.79	13.06	14.27	15.59	16.90	18.10	19.52	20.44	21.47	22.25				0.22	1.10	1.77	1.98		
2000	8.16	10.53	11.87	13.14	14.34	15.65	16.95	18.13	19.50	20.37	21.32	22.02				0.23	1.13	1.81	2.04		
2050	8.20	10.58	11.92	13.20	14.40	15.70	16.97	18.12	19.44							0.23	1.16	1.86	2.09		
2100	8.23	10.63	11.97	13.24	14.43	15.72	16.97	18.09	19.35							0.24	1.19	1.90	2.14		
2150	8.25	10.66	12.00	13.27	14.45	15.72	16.95	18.03	19.23							0.24	1.22	1.95	2.19		
2200	8.26	10.68	12.02	13.28	14.45	15.71	16.90	17.94	19.07							0.25	1.24	1.99	2.24		
2250	8.26	10.69	12.03	13.28	14.44	15.67	16.83	17.82	18.87							0.25	1.27	2.04	2.29		
2300	8.25	10.68	12.02	13.26	14.40	15.60	16.73									0.26	1.30	2.08	2.34		
2350	8.24	10.67	12.00	13.23	14.35	15.52	16.60									0.27	1.33	2.13	2.39		
2400	8.21	10.64	11.96	13.17	14.27	15.41	16.45									0.27	1.36	2.17	2.44		
2450	8.18	10.60	11.91	13.10	14.18	15.28	16.26									0.28	1.39	2.22	2.49		
2500	8.13	10.55	11.84	13.02	14.07	15.13	16.06									0.28	1.41	2.26	2.54		
2550	8.08	10.48	11.76	12.91	13.94											0.29	1.44	2.31	2.60		
2600	8.01	10.40	11.66	12.79	13.78											0.29	1.47	2.35	2.65		
2650	7.94	10.31	11.55	12.65	13.61											0.30	1.50	2.40	2.70		
2700	7.86	10.20	11.42	12.49	13.41											0.31	1.53	2.44	2.75		
2750	7.76	10.08	11.28	12.32	13.19											0.31	1.56	2.49	2.80		
2800	7.66	9.95	11.12	12.12												0.32	1.58	2.53	2.85		
2850	7.54	9.81	10.94	11.91												0.32	1.61	2.58	2.90		
2900	7.42	9.64	10.75	11.67												0.33	1.64	2.63	2.95		
2950	7.28	9.47	10.54	11.42												0.33	1.67	2.67	3.00		
3000	7.14	9.28	10.31	11.15												0.34	1.70	2.72	3.05		
3050	6.98	9.08														0.35	1.73	2.76	3.10		
3100	6.81	8.86														0.35	1.75	2.81	3.15		
3150	6.63	8.62			</																

POWER RATINGS

optibelt VB PROFILE 25

NOMINAL POWER RATING P_N [kW] FOR $\beta = 180^\circ$ AND $L_d = 4561$ mm

Table 54

Pulleys	v [m/s]	n_k [min ⁻¹]	Datum diameter of small pulley d_{dk} [mm]									Additional power [kW] per belt for speed ratio i				
			224	236	250	280	315	355	400	450	500	560	1.01 to 1.05	1.06 to 1.26	1.27 to 1.57	> 1.57
Statically balanced		700	5.68	6.47	7.38	9.28	11.45	13.84	16.43	19.16	21.74	24.62	0.12	0.61	0.97	1.09
		950	6.86	7.86	9.00	11.38	14.03	16.90	19.91	22.94	25.63	28.37	0.16	0.82	1.32	1.48
		1450	8.15	9.43	10.88	13.78	16.81	19.77	22.40				0.25	1.26	2.01	2.26
		2850											0.49	2.47	3.95	4.44
		50	0.71	0.78	0.87	1.05	1.26	1.50	1.76	2.06	2.35	2.69	0.01	0.04	0.07	0.08
		100	1.26	1.40	1.56	1.91	2.31	2.76	3.26	3.81	4.35	5.00	0.02	0.09	0.14	0.16
		150	1.76	1.96	2.20	2.69	3.27	3.92	4.64	5.44	6.22	7.15	0.03	0.13	0.21	0.23
		200	2.22	2.48	2.79	3.43	4.18	5.02	5.96	6.98	7.99	9.19	0.03	0.17	0.28	0.31
		250	2.65	2.97	3.34	4.13	5.04	6.07	7.21	8.46	9.69	11.14	0.04	0.22	0.35	0.39
		300	3.06	3.43	3.87	4.80	5.87	7.08	8.41	9.87	11.30	12.99	0.05	0.26	0.42	0.47
		350	3.44	3.88	4.38	5.44	6.67	8.05	9.57	11.23	12.86	14.76	0.06	0.30	0.49	0.55
		400	3.81	4.30	4.86	6.06	7.43	8.98	10.68	12.53	14.34	16.45	0.07	0.35	0.55	0.62
		450	4.16	4.70	5.33	6.65	8.17	9.87	11.75	13.78	15.75	18.05	0.08	0.39	0.62	0.70
		500	4.49	5.09	5.77	7.22	8.88	10.74	12.77	14.97	17.10	19.56	0.09	0.43	0.69	0.78
		550	4.81	5.45	6.20	7.77	9.56	11.56	13.75	16.11	18.37	20.97	0.10	0.48	0.76	0.86
		600	5.12	5.81	6.61	8.29	10.22	12.36	14.69	17.18	19.57	22.29	0.10	0.52	0.83	0.94
		650	5.41	6.15	7.00	8.80	10.85	13.12	15.58	18.20	20.70	23.51	0.11	0.56	0.90	1.01
		700	5.68	6.47	7.38	9.28	11.45	13.84	16.43	19.16	21.74	24.62	0.12	0.61	0.97	1.09
		750	5.95	6.78	7.73	9.75	12.02	14.53	17.22	20.05	22.70	25.61	0.13	0.65	1.04	1.17
		800	6.20	7.07	8.08	10.19	12.57	15.18	17.97	20.88	23.57	26.49	0.14	0.69	1.11	1.25
		850	6.43	7.35	8.40	10.61	13.09	15.79	18.67	21.64	24.35	27.25	0.15	0.74	1.18	1.33
		900	6.65	7.61	8.71	11.00	13.57	16.37	19.31	22.33	25.04	27.88	0.16	0.78	1.25	1.40
		950	6.86	7.86	9.00	11.38	14.03	16.90	19.91	22.94	25.63	28.37	0.16	0.82	1.32	1.48
		1000	7.06	8.09	9.27	11.73	14.46	17.40	20.44	23.48	26.12	28.72	0.17	0.87	1.39	1.56
		1050	7.24	8.30	9.52	12.06	14.86	17.85	20.92	23.93	26.50	28.93	0.18	0.91	1.46	1.64
		1100	7.40	8.50	9.76	12.36	15.22	18.26	21.33	24.31	26.77	28.99	0.19	0.95	1.53	1.72
		1150	7.55	8.69	9.98	12.64	15.56	18.62	21.69	24.60	26.92	28.88	0.20	1.00	1.60	1.79
		1200	7.69	8.85	10.18	12.90	15.86	18.93	21.98	24.80	26.96	28.62	0.21	1.04	1.66	1.87
		1250	7.81	9.00	10.36	13.13	16.12	19.20	22.20	24.90	26.87	28.18	0.22	1.08	1.73	1.95
		1300	7.92	9.14	10.52	13.33	16.35	19.42	22.36	24.92			0.23	1.13	1.80	2.03
1350	8.02	9.25	10.66	13.51	16.54	19.59	22.45	24.83			0.23	1.17	1.87	2.10		
1400	8.09	9.35	10.78	13.66	16.69	19.71	22.46	24.65			0.24	1.21	1.94	2.18		
1450	8.15	9.43	10.88	13.78	16.81	19.77	22.40	24.36			0.25	1.26	2.01	2.26		
1500	8.20	9.50	10.96	13.87	16.89	19.78	22.26	23.96			0.26	1.30	2.08	2.34		
1550	8.23	9.54	11.01	13.93	16.92	19.73					0.27	1.34	2.15	2.42		
1600	8.24	9.57	11.05	13.97	16.92	19.63					0.28	1.39	2.22	2.49		
1650	8.24	9.57	11.06	13.97	16.87	19.46					0.29	1.43	2.29	2.57		
1700	8.22	9.56	11.04	13.94	16.78	19.24					0.29	1.47	2.36	2.65		
1750	8.18	9.52	11.01	13.88	16.64	18.95					0.30	1.52	2.43	2.73		
1800	8.12	9.47	10.95	13.79	16.46						0.31	1.56	2.50	2.81		
1850	8.04	9.39	10.87	13.66	16.23						0.32	1.60	2.57	2.88		
1900	7.95	9.29	10.76	13.50	15.95						0.33	1.65	2.64	2.96		
1950	7.84	9.17	10.62	13.30	15.63						0.34	1.69	2.70	3.04		
2000	7.70	9.03	10.46	13.07	15.25						0.35	1.73	2.77	3.12		
2050	7.55	8.87	10.27	12.80							0.36	1.78	2.84	3.20		
2100	7.38	8.68	10.06	12.49							0.36	1.82	2.91	3.27		
2150	7.19	8.47	9.82	12.15							0.37	1.86	2.98	3.35		
2200	6.97	8.23	9.55	11.76							0.38	1.91	3.05	3.43		
2250	6.74	7.97	9.25	11.34							0.39	1.95	3.12	3.51		
2300	6.48	7.69	8.92								0.40	1.99	3.19	3.59		
2350	6.21	7.38	8.56								0.41	2.04	3.26	3.66		
2400	5.91	7.04	8.17								0.42	2.08	3.33	3.74		
2450	5.58	6.68	7.75								0.42	2.12	3.40	3.82		
2500	5.24	6.29	7.30								0.43	2.17	3.47	3.90		

v > 30 m/s.
Please consult our
Application Engineering
Department.

30

Dynamically balanced (for details see DIN 2211)

v [m/s]

Pulleys

POWER RATINGS

optibelt VB PROFILE D/32

NOMINAL POWER RATING P_N [kW] FOR $\beta = 180^\circ$ AND $L_d = 6375$ mm

Table 55

Pulleys	v [m/s]	n_k [min ⁻¹]	Datum diameter of small pulley d_{dk} [mm]													Additional power [kW] per belt for speed ratio i			
			315	355	375	400	425	450	500	560	630	670	710	750	800	900	1.01 to 1.05	1.06 to 1.26	1.27 to 1.57
5	700	15.30	19.17	21.05	23.36	25.62	27.82	32.05	36.82	41.91	44.59	47.08	49.38	51.98	56.17	0.23	1.14	1.82	2.05
	950	18.50	23.20	25.45	28.15	30.75	33.23	37.80	42.59	47.12	49.16	50.77	51.93	52.71	51.90	0.31	1.54	2.47	2.78
	1450	21.43	26.56	28.81	31.31	33.45	35.22	37.54	38.01	35.03						0.47	2.36	3.77	4.24
	20	0.80	0.96	1.04	1.14	1.24	1.34	1.54	1.78	2.05	2.21	2.36	2.51	2.71	3.08	0.01	0.03	0.05	0.06
	40	1.46	1.77	1.93	2.12	2.31	2.50	2.87	3.32	3.84	4.13	4.42	4.71	5.07	5.79	0.01	0.06	0.10	0.12
	60	2.08	2.53	2.75	3.03	3.31	3.58	4.13	4.77	5.52	5.95	6.37	6.79	7.31	8.34	0.02	0.10	0.16	0.18
	80	2.66	3.25	3.54	3.90	4.26	4.61	5.32	6.17	7.14	7.69	8.24	8.78	9.46	10.80	0.03	0.13	0.21	0.23
	100	3.22	3.94	4.29	4.74	5.18	5.61	6.48	7.51	8.70	9.38	10.05	10.71	11.54	13.18	0.03	0.16	0.26	0.29
	120	3.76	4.61	5.03	5.55	6.07	6.58	7.61	8.82	10.23	11.02	11.81	12.59	13.56	15.49	0.04	0.19	0.31	0.35
	140	4.28	5.26	5.74	6.34	6.94	7.53	8.71	10.10	11.71	12.62	13.52	14.42	15.53	17.73	0.05	0.23	0.36	0.41
	160	4.79	5.89	6.43	7.11	7.78	8.45	9.78	11.35	13.16	14.19	15.20	16.21	17.46	19.93	0.05	0.26	0.42	0.47
	180	5.29	6.51	7.11	7.87	8.61	9.36	10.83	12.57	14.58	15.72	16.84	17.96	19.34	22.06	0.06	0.29	0.47	0.53
	200	5.77	7.11	7.78	8.61	9.43	10.24	11.86	13.77	15.97	17.22	18.45	19.67	21.18	24.15	0.06	0.32	0.52	0.58
	220	6.24	7.71	8.43	9.33	10.22	11.11	12.87	14.95	17.34	18.69	20.02	21.34	22.97	26.18	0.07	0.36	0.57	0.64
240	6.70	8.29	9.07	10.04	11.01	11.97	13.86	16.10	18.68	20.12	21.56	22.98	24.73	28.16	0.08	0.39	0.62	0.70	
260	7.16	8.86	9.70	10.74	11.78	12.80	14.84	17.24	19.99	21.53	23.06	24.58	26.44	30.09	0.08	0.42	0.68	0.76	
280	7.60	9.42	10.31	11.43	12.53	13.63	15.79	18.35	21.27	22.91	24.54	26.14	28.11	31.96	0.09	0.45	0.73	0.82	
300	8.04	9.97	10.92	12.10	13.27	14.44	16.73	19.44	22.53	24.27	25.98	27.67	29.74	33.78	0.10	0.49	0.78	0.88	
320	8.47	10.51	11.51	12.77	14.00	15.23	17.66	20.51	23.77	25.59	27.39	29.16	31.33	35.55	0.10	0.52	0.83	0.94	
340	8.89	11.04	12.10	13.42	14.72	16.01	18.56	21.56	24.97	26.88	28.76	30.61	32.87	37.26	0.11	0.55	0.88	0.99	
360	9.30	11.56	12.68	14.06	15.43	16.78	19.46	22.59	26.16	28.15	30.10	32.02	34.37	38.90	0.12	0.58	0.94	1.05	
380	9.71	12.07	13.24	14.69	16.12	17.54	20.33	23.60	27.31	29.38	31.41	33.40	35.83	40.49	0.12	0.62	0.99	1.11	
400	10.11	12.58	13.80	15.31	16.80	18.28	21.19	24.59	28.44	30.59	32.68	34.74	37.24	42.02	0.13	0.65	1.04	1.17	
420	10.50	13.08	14.35	15.92	17.47	19.01	22.03	25.56	29.55	31.76	33.92	36.03	38.60	43.48	0.14	0.68	1.09	1.23	
440	10.88	13.56	14.89	16.52	18.13	19.73	22.86	26.51	30.62	32.90	35.12	37.29	39.91	44.88	0.14	0.71	1.14	1.29	
460	11.26	14.04	15.41	17.11	18.78	20.43	23.67	27.44	31.67	34.01	36.29	38.50	41.18	46.21	0.15	0.75	1.20	1.34	
480	11.63	14.52	15.93	17.69	19.42	21.12	24.46	28.34	32.69	35.09	37.41	39.67	42.39	47.47	0.16	0.78	1.25	1.40	
500	12.00	14.98	16.45	18.25	20.04	21.80	25.24	29.23	33.69	36.13	38.50	40.80	43.55	48.66	0.16	0.81	1.30	1.46	
520	12.36	15.44	16.95	18.81	20.65	22.46	26.00	30.09	34.65	37.14	39.55	41.88	44.66	49.78	0.17	0.84	1.35	1.52	
540	12.71	15.88	17.44	19.36	21.25	23.11	26.74	30.93	35.58	38.12	40.56	42.91	45.71	50.82	0.18	0.88	1.40	1.58	
560	13.06	16.32	17.92	19.90	21.84	23.75	27.47	31.75	36.49	39.06	41.53	43.90	46.71	51.78	0.18	0.91	1.46	1.64	
580	13.40	16.75	18.40	20.42	22.42	24.37	28.18	32.55	37.36	39.96	42.46	44.84	47.64	52.67	0.19	0.94	1.51	1.69	
600	13.73	17.18	18.86	20.94	22.98	24.98	28.87	33.32	38.20	40.83	43.34	45.73	48.52	53.47	0.19	0.97	1.56	1.75	
620	14.06	17.59	19.32	21.45	23.53	25.58	29.54	34.07	39.01	41.66	44.18	46.56	49.34	54.19	0.20	1.01	1.61	1.81	
640	14.38	18.00	19.77	21.94	24.07	26.16	30.20	34.79	39.79	42.45	44.98	47.35	50.10	54.82	0.21	1.04	1.66	1.87	
660	14.69	18.40	20.20	22.43	24.60	26.73	30.83	35.49	40.53	43.20	45.72	48.08	50.79	55.36	0.21	1.07	1.72	1.93	
680	15.00	18.79	20.63	22.90	25.11	27.28	31.45	36.17	41.24	43.92	46.43	48.76	51.42	55.81	0.22	1.10	1.77	1.99	
700	15.30	19.17	21.05	23.36	25.62	27.82	32.05	36.82	41.91	44.59	47.08	49.38	51.98	56.17	0.23	1.14	1.82	2.05	
720	15.59	19.54	21.46	23.81	26.11	28.34	32.63	37.44	42.55	45.22	47.68	49.95	52.47	56.44	0.23	1.17	1.87	2.10	
740	15.88	19.90	21.86	24.25	26.58	28.85	33.19	38.04	43.16	45.80	48.24	50.45	52.89	56.61	0.24	1.20	1.92	2.16	
760	16.16	20.26	22.25	24.68	27.04	29.34	33.73	38.61	43.72	46.35	48.74	50.90	53.24	56.67	0.25	1.23	1.98	2.22	
780	16.44	20.61	22.63	25.10	27.49	29.82	34.25	39.15	44.25	46.84	49.19	51.29	53.52	56.64	0.25	1.27	2.03	2.28	
800	16.71	20.95	23.00	25.50	27.93	30.28	34.75	39.66	44.74	47.30	49.59	51.61	53.73	56.50	0.26	1.30	2.08	2.34	
820	16.97	21.28	23.36	25.90	28.35	30.73	35.23	40.15	45.19	47.70	49.94	51.87			0.27	1.33	2.13	2.40	
840	17.22	21.60	23.71	26.28	28.76	31.16	35.68	40.61	45.60	48.06	50.22	52.07			0.27	1.36	2.18	2.45	
860	17.47	21.91	24.05	26.65	29.16	31.57	36.12	41.04	45.97	48.38	50.46	52.20			0.28	1.40	2.24	2.51	
880	17.71	22.21	24.38	27.00	29.54	31.97	36.53	41.44	46.30	48.64	50.63	52.26			0.29	1.43	2.29	2.57	
900	17.95	22.51	24.70	27.35	29.90	32.35	36.92	41.81	46.59	48.85	50.74	52.25			0.29	1.46	2.34	2.63	
920	18.18	22.79	25.00	27.68	30.25	32.71	37.29	42.14	46.84	49.01					0.30	1.49	2.39	2.69	
940	18.40	23.07	25.30	28.00	30.59	33.06	37.64	42.45	47.04	49.12					0.31	1.53	2.44	2.75	
960	18.61	23.33	25.59	28.31	30.91	33.39	37.96	42.72	47.19	49.18					0.31	1.56	2.50	2.81	
980	18.82	23.59	25.86	28.60	31.21	33.70	38.26	42.97	47.31	49.18					0.32	1.59	2.55	2.86	
1000	19.02	23.83	26.13	28.88	31.50	33.99	38.53	43.18	47.37	49.13					0.32	1.62	2.60	2.92	
1020	19.21	24.07	26.38	29.15	31.78	34.26	38.78	43.35	47.39						0.33	1.66	2.65	2.98	
1040	19.39	24.30	26.62	29.40	32.04	34.52	39.01	43.49	47.36						0.34	1.69	2.70	3.04	
1060	19.57	24.51	26.85	29.64	32.28	34.76	39.21	43.60	47.29						0.34	1.72	2.76	3.10	
1080	19.74	24.72	27.07	29.87	32.50	34.97	39.38	43.67	47.16						0.35	1.75	2.81	3.16	
1100	19.90	24.92	27.27	30.08	32.71	35.17	39.53	43.71	46.99						0.36	1.79	2.86	3.21	
1120	20.06	25.10	27.47	30.28	32.91	35.35	39.66												

POWER RATINGS

optibelt **VB PROFILE E/40**

NOMINAL POWER RATING P_N [kW] FOR $\beta = 180^\circ$ AND $L_d = 7180$ mm

Table 56

Pulleys	v [m/s]	n_k [min ⁻¹]	Datum diameter of small pulley d_{dk} [mm]											Additional power [kW] per belt for speed ratio i			
			450	500	560	630	670	710	750	800	850	900	950	1000	1.01 to 1.05	1.06 to 1.26	1.27 to 1.57
5	700	26.44	31.70	37.57	43.78	47.00	49.97	52.68	55.67	58.21	60.27	61.83	62.87	0.38	1.92	3.07	3.45
	950	29.78	35.30	40.95	46.07	48.23	49.80	50.75	51.00	50.17	48.20	45.02		0.52	2.60	4.16	4.68
	1450	24.24	26.19	25.31	19.38									0.79	3.97	6.35	7.14
	20	1.47	1.72	2.02	2.37	2.57	2.76	2.96	3.20	3.44	3.68	3.92	4.16	0.01	0.05	0.09	0.10
	40	2.70	3.17	3.74	4.40	4.77	5.14	5.51	5.97	6.42	6.88	7.33	7.78	0.02	0.11	0.18	0.20
	60	3.83	4.52	5.34	6.29	6.83	7.37	7.90	8.57	9.22	9.88	10.53	11.18	0.03	0.16	0.26	0.30
	80	4.90	5.80	6.87	8.10	8.80	9.50	10.19	11.05	11.90	12.75	13.60	14.43	0.04	0.22	0.35	0.39
	100	5.92	7.03	8.34	9.85	10.70	11.55	12.40	13.44	14.49	15.52	16.55	17.57	0.05	0.27	0.44	0.49
	120	6.91	8.21	9.76	11.53	12.54	13.54	14.53	15.77	16.99	18.20	19.41	20.60	0.07	0.33	0.53	0.59
	140	7.87	9.36	11.13	13.17	14.33	15.47	16.61	18.02	19.42	20.80	22.18	23.54	0.08	0.38	0.61	0.69
160	8.80	10.48	12.47	14.77	16.06	17.35	18.63	20.21	21.78	23.33	24.87	26.39	0.09	0.44	0.70	0.79	
180	9.70	11.57	13.78	16.32	17.76	19.18	20.59	22.34	24.07	25.79	27.48	29.16	0.10	0.49	0.79	0.89	
200	10.58	12.63	15.05	17.84	19.41	20.97	22.51	24.42	26.30	28.17	30.01	31.83	0.11	0.55	0.88	0.98	
220	11.43	13.66	16.29	19.32	21.02	22.71	24.37	26.44	28.47	30.48	32.47	34.42	0.12	0.60	0.96	1.08	
240	12.27	14.67	17.51	20.76	22.59	24.40	26.19	28.40	30.58	32.73	34.84	36.93	0.13	0.66	1.05	1.18	
260	13.08	15.66	18.69	22.17	24.12	26.05	27.96	30.31	32.62	34.90	37.14	39.34	0.14	0.71	1.14	1.28	
280	13.88	16.62	19.85	23.54	25.62	27.66	29.68	32.16	34.60	37.00	39.35	41.66	0.15	0.77	1.23	1.38	
300	14.66	17.56	20.98	24.88	27.07	29.23	31.35	33.96	36.52	39.02	41.48	43.88	0.16	0.82	1.31	1.48	
320	15.42	18.48	22.09	26.19	28.49	30.75	32.97	35.70	38.37	40.97	43.52	46.01	0.18	0.88	1.40	1.58	
340	16.16	19.38	23.16	27.46	29.86	32.22	34.54	37.38	40.15	42.85	45.48	48.03	0.19	0.93	1.49	1.67	
360	16.88	20.26	24.21	28.70	31.20	33.65	36.06	39.00	41.86	44.64	47.34	49.95	0.20	0.99	1.58	1.77	
380	17.59	21.11	25.23	29.90	32.49	35.04	37.52	40.55	43.50	46.35	49.10	51.76	0.21	1.04	1.66	1.87	
400	18.28	21.94	26.23	31.06	33.75	36.37	38.93	42.05	45.06	47.97	50.77	53.47	0.22	1.09	1.75	1.97	
420	18.95	22.76	27.19	32.19	34.96	37.66	40.29	43.48	46.55	49.51	52.34	55.05	0.23	1.15	1.84	2.07	
440	19.60	23.54	28.13	33.29	36.13	38.90	41.59	44.84	47.97	50.96	53.81	56.52	0.24	1.20	1.93	2.17	
460	20.24	24.31	29.04	34.34	37.26	40.09	42.83	46.14	49.30	52.31	55.17	57.86	0.25	1.26	2.02	2.27	
480	20.86	25.06	29.92	35.36	38.34	41.23	44.02	47.37	50.55	53.57	56.42	59.08	0.26	1.31	2.10	2.36	
500	21.46	25.78	30.78	36.33	39.37	42.31	45.14	48.52	51.72	54.73	57.55	60.16	0.27	1.37	2.19	2.46	
520	22.04	26.48	31.60	37.27	40.36	43.34	46.20	49.60	52.80	55.79	58.57	61.11	0.28	1.42	2.28	2.56	
540	22.61	27.16	32.39	38.17	41.31	44.32	47.20	50.60	53.79	56.75	59.46	61.92	0.30	1.48	2.37	2.66	
560	23.15	27.81	33.15	39.03	42.20	45.24	48.13	51.53	54.69	57.60	60.23	62.59	0.31	1.53	2.45	2.76	
580	23.68	28.44	33.88	39.84	43.04	46.10	48.99	52.38	55.50	58.33	60.87	63.11	0.32	1.59	2.54	2.86	
600	24.19	29.04	34.58	40.61	43.84	46.90	49.79	53.14	56.21	58.96	61.39	63.48	0.33	1.64	2.63	2.95	
620	24.68	29.63	35.24	41.34	44.58	47.64	50.51	53.83	56.81	59.46	61.76		0.34	1.70	2.72	3.05	
640	25.15	30.18	35.88	42.02	45.27	48.32	51.17	54.42	57.32	59.85	62.00		0.35	1.75	2.80	3.15	
660	25.60	30.71	36.47	42.65	45.90	48.94	51.75	54.93	57.72	60.12	62.09		0.36	1.81	2.89	3.25	
680	26.03	31.22	37.04	43.24	46.48	49.49	52.25	55.34	58.02	60.26	62.04		0.37	1.86	2.98	3.35	
700	26.44	31.70	37.57	43.78	47.00	49.97	52.68	55.67	58.21	60.27	61.83		0.38	1.92	3.07	3.45	
720	26.84	32.15	38.06	44.27	47.47	50.39	53.02	55.90					0.39	1.97	3.15	3.55	
740	27.21	32.57	38.52	44.71	47.87	50.73	53.29	56.03					0.41	2.03	3.24	3.64	
760	27.56	32.97	38.94	45.10	48.22	51.01	53.47	56.06					0.42	2.08	3.33	3.74	
780	27.89	33.34	39.32	45.44	48.50	51.21	53.57	55.99					0.43	2.14	3.42	3.84	
800	28.19	33.68	39.66	45.73	48.72	51.34	53.59	55.82					0.44	2.19	3.50	3.94	
820	28.48	34.00	39.97	45.96	48.87	51.40							0.45	2.24	3.59	4.04	
840	28.74	34.28	40.23	46.13	48.96	51.38							0.46	2.30	3.68	4.14	
860	28.98	34.54	40.46	46.25	48.99	51.27							0.47	2.35	3.77	4.24	
880	29.20	34.76	40.64	46.32	48.94	51.09							0.48	2.41	3.86	4.33	
900	29.39	34.95	40.78	46.32	48.83	50.83							0.49	2.46	3.94	4.43	
920	29.57	35.11	40.88	46.27									0.50	2.52	4.03	4.53	
940	29.71	35.24	40.94	46.15									0.51	2.57	4.12	4.63	
960	29.84	35.34	40.95	45.98									0.53	2.63	4.21	4.73	
980	29.93	35.41	40.91	45.74									0.54	2.68	4.29	4.83	
1000	30.01	35.44	40.83	45.43									0.55	2.74	4.38	4.92	
1020	30.06	35.44	40.71	45.07									0.56	2.79	4.47	5.02	
1040	30.08	35.40	40.53	44.63									0.57	2.85	4.56	5.12	
1060	30.07	35.33	40.31	44.13									0.58	2.90	4.64	5.22	
1080	30.04	35.22	40.04	43.56									0.59	2.96	4.73	5.32	
1100	29.99	35.08	39.72	42.93									0.60	3.01	4.82	5.42	
1120	29.90	34.90	39.35										0.61	3.07	4.91	5.52	
1140	29.79	34.68	38.93										0.62	3.12	4.99	5.61	
1160	29.65	34.43	38.46										0.64	3.18	5.08	5.71	
1180	29.48	34.14	37.93										0.65	3.23	5.17	5.81	
1200	29.29	33.81	37.36										0.66	3.28	5.26	5.91	
1220	29.06	33.44											0.67	3.34	5.34	6.01	
1240	28.80	33.03											0.68	3.39	5.43	6.11	
1260	28.52	32.58											0.69	3.45	5.52	6.21	
1280	28.20	32.09											0.70	3.50	5.61	6.30	
1300	27.86	31.55											0.71	3.56	5.70	6.40	
v > 30 m/s. Please consult our Application Engineering Department.																	
													v [m/s]				
Dynamically balanced (for details see DIN 2211)																	
													Pulleys				

POWER RATINGS

optibelt **SUPER X-POWER M=S PROFILE XPZ, 3VX, 9JX**

NOMINAL POWER RATING P_N [kW] FOR $\beta = 180^\circ$ AND $L_d = 1600$ mm

Table 57

Pulleys	v [m/s]	n_k [min ⁻¹]	Datum diameter of small pulley d_{dk} [mm]																Additional power [kW] per belt for speed ratio i			
			56	60	63	71	80	85	90	95	100	112	125	140	160	180	200	1.01 to 1.05	1.06 to 1.26	1.27 to 1.57	> 1.57	
Statically balanced	5	700	0.72	0.84	0.92	1.14	1.39	1.53	1.80	1.94	2.26	2.42	2.61	3.00	3.51	4.02	4.53	0.01	0.06	0.08	0.10	
		950	0.92	1.07	1.18	1.48	1.80	1.98	2.34	2.52	2.94	3.15	3.39	3.91	4.58	5.25	5.90	0.01	0.08	0.11	0.13	
		1450	1.27	1.49	1.65	2.08	2.56	2.83	3.35	3.60	4.22	4.52	4.87	5.61	6.58	7.52	8.44	0.02	0.12	0.16	0.20	
		2850	2.07	2.46	2.76	3.54	4.39	4.86	5.78	6.24	7.30	7.82	8.42	9.67	11.26	12.77	14.17	0.04	0.23	0.32	0.40	
		100	0.14	0.16	0.18	0.22	0.26	0.28	0.33	0.35	0.41	0.43	0.46	0.53	0.62	0.71	0.80	0.00	0.01	0.01	0.01	
		200	0.26	0.30	0.32	0.39	0.47	0.52	0.61	0.65	0.75	0.80	0.86	0.99	1.16	1.32	1.49	0.00	0.02	0.02	0.03	
		300	0.36	0.42	0.46	0.56	0.67	0.74	0.87	0.93	1.08	1.15	1.24	1.42	1.66	1.90	2.14	0.00	0.02	0.03	0.04	
		400	0.46	0.53	0.58	0.71	0.86	0.95	1.11	1.19	1.39	1.48	1.60	1.83	2.15	2.46	2.76	0.00	0.03	0.05	0.06	
		500	0.55	0.64	0.70	0.86	1.05	1.15	1.35	1.45	1.69	1.81	1.94	2.23	2.62	2.99	3.37	0.01	0.04	0.06	0.07	
		600	0.64	0.74	0.81	1.01	1.22	1.34	1.58	1.70	1.98	2.12	2.28	2.62	3.07	3.51	3.95	0.01	0.05	0.07	0.08	
		700	0.72	0.84	0.92	1.14	1.39	1.53	1.80	1.94	2.26	2.42	2.61	3.00	3.51	4.02	4.53	0.01	0.06	0.08	0.10	
		800	0.80	0.93	1.03	1.28	1.56	1.72	2.02	2.18	2.54	2.72	2.93	3.37	3.95	4.52	5.08	0.01	0.06	0.09	0.11	
		900	0.88	1.02	1.13	1.41	1.72	1.90	2.24	2.41	2.81	3.01	3.24	3.73	4.37	5.01	5.63	0.01	0.07	0.10	0.13	
		1000	0.96	1.11	1.23	1.54	1.88	2.07	2.45	2.63	3.08	3.29	3.55	4.09	4.79	5.48	6.17	0.01	0.08	0.11	0.14	
		1100	1.03	1.20	1.33	1.66	2.04	2.24	2.65	2.86	3.34	3.57	3.85	4.43	5.20	5.95	6.69	0.01	0.09	0.12	0.15	
		1200	1.10	1.28	1.42	1.79	2.19	2.41	2.86	3.07	3.59	3.85	4.15	4.78	5.60	6.41	7.21	0.01	0.10	0.14	0.17	
		1300	1.17	1.37	1.52	1.91	2.34	2.58	3.05	3.29	3.84	4.12	4.44	5.11	6.00	6.86	7.71	0.02	0.10	0.15	0.18	
		1400	1.24	1.45	1.61	2.03	2.49	2.74	3.25	3.50	4.09	4.39	4.73	5.45	6.38	7.30	8.20	0.02	0.11	0.16	0.19	
		1500	1.30	1.53	1.70	2.14	2.63	2.91	3.44	3.71	4.34	4.65	5.01	5.77	6.77	7.74	8.69	0.02	0.12	0.17	0.21	
		1600	1.37	1.61	1.78	2.25	2.78	3.06	3.63	3.91	4.58	4.91	5.29	6.09	7.14	8.16	9.16	0.02	0.13	0.18	0.22	
		1700	1.43	1.68	1.87	2.37	2.92	3.22	3.82	4.11	4.82	5.16	5.56	6.41	7.51	8.58	9.62	0.02	0.14	0.19	0.24	
		1800	1.49	1.76	1.95	2.48	3.06	3.37	4.00	4.31	5.05	5.41	5.83	6.72	7.87	8.99	10.07	0.02	0.14	0.20	0.25	
		1900	1.55	1.83	2.04	2.59	3.19	3.53	4.18	4.51	5.28	5.66	6.10	7.02	8.22	9.39	10.52	0.02	0.15	0.22	0.26	
		2000	1.61	1.90	2.12	2.69	3.33	3.67	4.36	4.70	5.51	5.90	6.36	7.32	8.57	9.78	10.95	0.02	0.16	0.23	0.28	
		2100	1.67	1.97	2.20	2.80	3.46	3.82	4.54	4.89	5.73	6.14	6.62	7.62	8.91	10.16	11.37	0.03	0.17	0.24	0.29	
		2200	1.72	2.04	2.28	2.90	3.59	3.97	4.71	5.08	5.95	6.38	6.87	7.91	9.25	10.54	11.78	0.03	0.18	0.25	0.31	
		2300	1.78	2.11	2.36	3.00	3.72	4.11	4.88	5.26	6.17	6.61	7.12	8.19	9.58	10.91	12.18	0.03	0.18	0.26	0.32	
		2400	1.83	2.18	2.43	3.10	3.84	4.25	5.05	5.45	6.38	6.84	7.37	8.47	9.90	11.26	12.57	0.03	0.19	0.27	0.33	
		2500	1.89	2.24	2.51	3.20	3.97	4.39	5.22	5.63	6.59	7.06	7.61	8.75	10.22	11.61	12.94	0.03	0.20	0.28	0.35	
		2600	1.94	2.31	2.58	3.30	4.09	4.53	5.38	5.80	6.80	7.29	7.85	9.02	10.52	11.95	13.31	0.03	0.21	0.30	0.36	
		2700	1.99	2.37	2.65	3.39	4.21	4.66	5.54	5.98	7.00	7.50	8.08	9.29	10.83	12.29	13.66	0.03	0.22	0.31	0.38	
		2800	2.04	2.43	2.72	3.49	4.33	4.80	5.70	6.15	7.20	7.72	8.31	9.55	11.12	12.61	14.01	0.03	0.22	0.32	0.39	
		2900	2.09	2.49	2.79	3.58	4.45	4.93	5.86	6.32	7.40	7.93	8.54	9.80	11.41	12.92	14.34	0.04	0.23	0.33	0.40	
		3000	2.14	2.55	2.86	3.67	4.57	5.06	6.02	6.49	7.60	8.14	8.76	10.05	11.69	13.22	14.65	0.04	0.24	0.34	0.42	
		3100	2.19	2.61	2.93	3.76	4.68	5.18	6.17	6.65	7.79	8.34	8.98	10.29	11.96	13.52	14.96	0.04	0.25	0.35	0.43	
		3200	2.23	2.67	3.00	3.85	4.80	5.31	6.32	6.81	7.97	8.54	9.19	10.53	12.23	13.80	15.25	0.04	0.26	0.36	0.45	
		3300	2.28	2.73	3.06	3.94	4.91	5.43	6.47	6.97	8.16	8.74	9.40	10.77	12.49	14.08	15.53	0.04	0.26	0.37	0.46	
		3400	2.32	2.79	3.13	4.03	5.02	5.56	6.61	7.13	8.34	8.93	9.60	11.00	12.74	14.34	15.79	0.04	0.27	0.39	0.47	
		3500	2.37	2.84	3.19	4.11	5.13	5.68	6.76	7.28	8.52	9.12	9.81	11.22	12.98	14.59	16.04	0.04	0.28	0.40	0.49	
		3600	2.41	2.90	3.25	4.20	5.23	5.80	6.90	7.44	8.70	9.31	10.00	11.44	13.22	14.83	16.28	0.04	0.29	0.41	0.50	
3700	2.45	2.95	3.32	4.28	5.34	5.91	7.04	7.59	8.87	9.49	10.20	11.65	13.44	15.07	16.50	0.05	0.30	0.42	0.52			
3800	2.50	3.00	3.38	4.36	5.44	6.03	7.17	7.73	9.04	9.67	10.38	11.85	13.66	15.29	16.71	0.05	0.30	0.43	0.53			
3900	2.54	3.05	3.44	4.44	5.54	6.14	7.31	7.88	9.20	9.84	10.57	12.05	13.87	15.50	16.90	0.05	0.31	0.44	0.54			
4000	2.58	3.10	3.49	4.52	5.64	6.25	7.44	8.02	9.36	10.01	10.75	12.25	14.08	15.69	17.08	0.05	0.32	0.45	0.56			
4100	2.61	3.15	3.55	4.60	5.74	6.36	7.57	8.16	9.52	10.18	10.92	12.44	14.27	15.88	17.24	0.05	0.33	0.47	0.57			
4200	2.65	3.20	3.61	4.67	5.84	6.47	7.70	8.29	9.67	10.34	11.09	12.62	14.46	16.05	17.39	0.05	0.34	0.48	0.58			
4300	2.69	3.25	3.66	4.75	5.93	6.57	7.82	8.43	9.83	10.50	11.26	12.79	14.63	16.22	17.52	0.05	0.34	0.49	0.60			
4400	2.73	3.30	3.72	4.82	6.03	6.68	7.94	8.56	9.97	10.65	11.42	12.96	14.80	16.37	17.63	0.05	0.35	0.50	0.61			
4500	2.76	3.34	3.77	4.89	6.12	6.78	8.06	8.68	10.12	10.80	11.58	13.13	14.96	16.50	17.73	0.06	0.36	0.51	0.63			
4600	2.80	3.39	3.82	4.97	6.21	6.88	8.18	8.81	10.26	10.95	11.73	13.28	15.11	16.63	17.81	0.06	0.37	0.52	0.64			
4700	2.83	3.43	3.87	5.03	6.30	6.98	8.30	8.93	10.40	11.09	11.87	13.43	15.25	16.74	17.87	0.06	0.38	0.53	0.65			
4800	2.86	3.47	3.93	5.10	6.38	7.07	8.41	9.05	10.53	11.23	12.02	13.58	15.38	16.84	17.92	0.06	0.38	0.54	0.67			
4900	2.90	3.52	3.97	5.17	6.47	7.17	8.52	9.17	10.66	11.36	12.15	13.71	15.50	16.92	17.94	0.06	0.39	0.56	0.68			
5000	2.93	3.56	4.02	5.24	6.55	7.26	8.63	9.28	10.78	11.49	12.28	13.84	15.61	17.00	17.95	0.06	0.40	0.57	0.70			
5100	2.96	3.60	4.07	5.30	6.63	7.35	8.73	9.39	10.90	11.62	12.41	13.97	15.72	17.05	17.94	0.06	0.41	0.58	0.71			
5200	2.99	3.64	4.12	5.36	6.71	7.44	8.83	9.50	11.02	11.74	12.53	14.08	15.81	17.10	17.91	0.06	0.42	0.59	0.72			
5300	3.02	3.68	4.16	5.43	6.79	7.53	8.93	9.61	11.14	11.85	12.65	14.19	15.89	17.13		0.07	0.42	0.60	0.74			
5400	3.05	3.71	4.21	5.49	6.87	7.61	9.03	9.71	11.25	11.96	12.76	14.30	15.96	17.14		0.07	0.43	0.61	0.75			
5500	3.07	3.75	4.25	5.55	6.94	7.69	9.12	9.81	11.35	12.07	12.87	14.39	16.02	17.14		0.07	0.44	0.62	0.77			
5600	3.10	3.79	4.29	5.60	7.02	7.77	9.22	9.90	11.45	12.17	12.97	14.48	16.07	17.13		0.07	0.45	0.64	0.78			
5800	3.15	3.86	4.37	5.72	7.16	7.93	9.39	10.09	11.64	12.36	13.15	14.63	16.14	17.06		0.07	0.46	0.66	0.81			
6000	3.20	3.92	4.45	5.82	7.29	8.07	9.56	10.26	11.82	12.53	13.31	14.75	16.16			0.07	0.48					

POWER RATINGS

optibelt SUPER X-POWER M=S PROFILE XPA

NOMINAL POWER RATING P_N [kW] FOR $\beta = 180^\circ$ AND $L_d = 2500$ mm

Table 58

Pulleys	v [m/s]	n_k [min ⁻¹]	Datum diameter of small pulley d_{jk} [mm]														Additional power [kW] per belt for speed ratio i				
			71	80	85	95	100	112	118	125	140	160	180	200	224	250	280	1.01 to 1.05	1.06 to 1.26	1.27 to 1.57	> 1.57
Statically balanced	5	700	1.12	1.55	1.78	2.25	2.48	3.04	3.31	3.63	4.32	5.22	6.11	7.00	8.05	9.18	10.46	0.02	0.13	0.19	0.23
		950	1.43	2.00	2.31	2.94	3.24	3.98	4.35	4.77	5.68	6.87	8.05	9.22	10.60	12.08	13.76	0.03	0.18	0.26	0.31
		1450	2.01	2.84	3.31	4.22	4.68	5.77	6.31	6.93	8.26	10.00	11.71	13.39	15.37	17.46	19.81	0.04	0.27	0.39	0.48
		2850	3.31	4.85	5.70	7.37	8.20	10.15	11.11	12.21	14.52	17.49	20.31	22.98	25.96	28.88	31.84	0.08	0.54	0.77	0.94
		100	0.22	0.28	0.32	0.40	0.43	0.52	0.57	0.62	0.73	0.87	1.02	1.16	1.33	1.52	1.73	0.00	0.02	0.03	0.03
		200	0.39	0.52	0.60	0.74	0.81	0.98	1.07	1.17	1.38	1.66	1.94	2.21	2.54	2.89	3.30	0.01	0.04	0.05	0.07
		300	0.55	0.75	0.85	1.06	1.17	1.42	1.54	1.69	2.00	2.41	2.81	3.22	3.70	4.21	4.81	0.01	0.06	0.08	0.10
		400	0.70	0.96	1.10	1.37	1.51	1.84	2.00	2.19	2.60	3.13	3.67	4.19	4.82	5.50	6.27	0.01	0.08	0.11	0.13
		500	0.85	1.16	1.33	1.67	1.84	2.25	2.45	2.68	3.18	3.84	4.50	5.15	5.92	6.75	7.70	0.01	0.09	0.13	0.16
		600	0.99	1.36	1.56	1.96	2.16	2.65	2.88	3.16	3.75	4.54	5.31	6.08	6.99	7.97	9.09	0.02	0.11	0.16	0.20
		700	1.12	1.55	1.78	2.25	2.48	3.04	3.31	3.63	4.32	5.22	6.11	7.00	8.05	9.18	10.46	0.02	0.13	0.19	0.23
		800	1.25	1.73	2.00	2.53	2.79	3.42	3.73	4.09	4.87	5.89	6.90	7.90	9.08	10.35	11.80	0.02	0.15	0.22	0.26
		900	1.37	1.91	2.21	2.80	3.09	3.80	4.14	4.55	5.41	6.55	7.67	8.78	10.10	11.51	13.11	0.03	0.17	0.24	0.30
		1000	1.50	2.09	2.42	3.07	3.39	4.17	4.55	5.00	5.94	7.20	8.43	9.65	11.10	12.64	14.39	0.03	0.19	0.27	0.33
		1100	1.61	2.26	2.62	3.33	3.69	4.53	4.95	5.44	6.47	7.83	9.18	10.51	12.08	13.75	15.65	0.03	0.21	0.30	0.36
		1200	1.73	2.43	2.82	3.59	3.98	4.89	5.34	5.87	6.99	8.46	9.92	11.35	13.04	14.84	16.87	0.04	0.23	0.32	0.40
		1300	1.84	2.60	3.02	3.85	4.26	5.24	5.73	6.30	7.50	9.09	10.64	12.18	13.99	15.91	18.07	0.04	0.25	0.35	0.43
		1400	1.95	2.76	3.21	4.10	4.54	5.59	6.12	6.72	8.01	9.70	11.36	12.99	14.92	16.95	19.23	0.04	0.27	0.38	0.46
		1500	2.06	2.92	3.40	4.35	4.82	5.94	6.49	7.14	8.50	10.30	12.06	13.79	15.82	17.97	20.37	0.04	0.28	0.40	0.49
		1600	2.16	3.08	3.59	4.59	5.09	6.28	6.87	7.55	9.00	10.89	12.75	14.58	16.71	18.96	21.47	0.05	0.30	0.43	0.53
		1700	2.27	3.24	3.77	4.83	5.36	6.61	7.23	7.95	9.48	11.48	13.43	15.34	17.58	19.93	22.53	0.05	0.32	0.46	0.56
		1800	2.37	3.39	3.95	5.07	5.63	6.94	7.60	8.35	9.96	12.05	14.10	16.10	18.43	20.87	23.56	0.05	0.34	0.48	0.59
		1900	2.47	3.54	4.13	5.31	5.89	7.27	7.96	8.75	10.43	12.62	14.75	16.84	19.26	21.78	24.55	0.06	0.36	0.51	0.63
		2000	2.56	3.69	4.31	5.54	6.15	7.59	8.31	9.14	10.89	13.17	15.40	17.56	20.06	22.66	25.50	0.06	0.38	0.54	0.66
		2100	2.66	3.83	4.48	5.77	6.40	7.91	8.66	9.52	11.34	13.72	16.03	18.26	20.85	23.52	26.42	0.06	0.40	0.56	0.69
2200	2.75	3.98	4.65	5.99	6.65	8.22	9.00	9.90	11.79	14.26	16.64	18.95	21.61	24.34	27.29	0.06	0.42	0.59	0.73		
2300	2.84	4.12	4.82	6.21	6.90	8.53	9.34	10.27	12.23	14.78	17.25	19.62	22.35	25.13	28.12	0.07	0.44	0.62	0.76		
2400	2.93	4.26	4.99	6.43	7.14	8.84	9.67	10.64	12.67	15.30	17.84	20.28	23.06	25.89	28.90	0.07	0.45	0.65	0.79		
2500	3.02	4.39	5.15	6.64	7.38	9.14	10.00	11.00	13.09	15.81	18.41	20.91	23.75	26.62	29.64	0.07	0.47	0.67	0.82		
2600	3.10	4.53	5.31	6.86	7.62	9.43	10.32	11.35	13.51	16.30	18.97	21.53	24.41	27.31	30.33	0.08	0.49	0.70	0.86		
2700	3.19	4.66	5.47	7.07	7.85	9.72	10.64	11.70	13.92	16.79	19.52	22.12	25.05	27.97	30.97	0.08	0.51	0.73	0.89		
2800	3.27	4.79	5.62	7.27	8.08	10.01	10.95	12.04	14.33	17.26	20.05	22.70	25.66	28.59	31.56	0.08	0.53	0.75	0.92		
2900	3.35	4.92	5.78	7.47	8.31	10.29	11.26	12.38	14.72	17.72	20.57	23.25	26.24	29.17	32.10	0.08	0.55	0.78	0.96		
3000	3.43	5.04	5.93	7.67	8.53	10.56	11.56	12.71	15.11	18.17	21.07	23.79	26.80	29.71	32.59	0.09	0.57	0.81	0.99		
3100	3.50	5.16	6.07	7.87	8.75	10.84	11.86	13.03	15.49	18.61	21.55	24.30	27.32	30.21	33.02	0.09	0.59	0.83	1.02		
3200	3.58	5.28	6.22	8.06	8.97	11.10	12.15	13.35	15.86	19.04	22.02	24.80	27.82	30.68	33.39	0.09	0.61	0.86	1.05		
3300	3.65	5.40	6.36	8.25	9.18	11.36	12.43	13.66	16.22	19.45	22.47	25.26	28.28	31.10	33.71	0.10	0.63	0.89	1.09		
3400	3.72	5.52	6.50	8.43	9.38	11.62	12.71	13.97	16.57	19.85	22.91	25.71	28.71	31.47	33.96	0.10	0.64	0.91	1.12		
3500	3.79	5.63	6.64	8.62	9.59	11.87	12.99	14.26	16.91	20.24	23.32	26.13	29.11	31.80	34.16	0.10	0.66	0.94	1.15		
3600	3.86	5.74	6.77	8.79	9.79	12.12	13.26	14.56	17.25	20.62	23.72	26.53	29.47	32.09	34.29	0.11	0.68	0.97	1.19		
3700	3.92	5.85	6.90	8.97	9.98	12.36	13.52	14.84	17.57	20.98	24.10	26.90	29.81	32.33	34.35	0.11	0.70	0.99	1.22		
3800	3.99	5.96	7.03	9.14	10.17	12.60	13.77	15.12	17.89	21.33	24.46	27.25	30.10	32.52		0.11	0.72	1.02	1.25		
3900	4.05	6.06	7.16	9.31	10.36	12.83	14.02	15.39	18.19	21.67	24.81	27.58	30.36	32.66		0.11	0.74	1.05	1.29		
4000	4.11	6.16	7.28	9.47	10.55	13.05	14.27	15.65	18.49	21.99	25.13	27.87	30.59	32.75		0.12	0.76	1.08	1.32		
4100	4.17	6.26	7.40	9.63	10.73	13.27	14.50	15.91	18.78	22.30	25.43	28.14	30.77	32.79		0.12	0.78	1.10	1.35		
4200	4.22	6.36	7.52	9.79	10.90	13.48	14.73	16.15	19.05	22.59	25.71	28.38	30.92	32.78		0.12	0.80	1.13	1.38		
4300	4.28	6.45	7.63	9.94	11.07	13.69	14.96	16.39	19.32	22.87	25.97	28.59	31.03			0.13	0.81	1.16	1.42		
4400	4.33	6.54	7.75	10.09	11.24	13.90	15.18	16.63	19.57	23.13	26.21	28.78	31.10			0.13	0.83	1.18	1.45		
4500	4.38	6.63	7.86	10.24	11.40	14.09	15.39	16.85	19.82	23.38	26.43	28.93	31.13			0.13	0.85	1.21	1.48		
4600	4.43	6.72	7.96	10.38	11.56	14.28	15.59	17.07	20.05	23.61	26.63	29.06	31.12			0.13	0.87	1.24	1.52		
4700	4.48	6.80	8.06	10.52	11.71	14.47	15.79	17.28	20.27	23.82	26.80	29.15				0.14	0.89	1.26	1.55		
4800	4.52	6.88	8.17	10.65	11.86	14.65	15.98	17.48	20.49	24.02	26.95	29.22				0.14	0.91	1.29	1.58		
4900	4.56	6.96	8.26	10.78	12.01	14.82	16.16	17.67	20.69	24.20	27.08	29.25				0.14	0.93	1.32	1.62		
5000	4.60	7.04	8.36	10.91	12.14	14.99	16.34	17.85	20.87	24.36	27.18	29.25				0.15	0.95	1.34	1.65		
5100	4.64	7.11	8.45	11.03	12.28	15.14	16.51	18.03	21.05	24.51	27.26	29.21				0.15	0.97	1.37	1.68		
5200	4.68	7.18	8.54	11.15	12.41	15.30	16.67	18.20	21.21	24.64	27.31	29.15				0.15	0.98	1.40	1.71		
5300	4.72	7.25	8.62	11.26	12.54	15.44	16.82	18.35	21.37	24.75	27.34					0.16	1.00	1.42	1.75		
5400	4.75	7.32	8.70	11.37	12.66	15.58	16.97	18.50	21.51	24.85	27.35					0.16	1.02	1.45	1.78		
5500	4.78	7.38	8.78	11.48	12.77	15.72	17.10	18.64	21.63	24.92	27.32					0.16	1.04	1.48	1.81		
5600	4.81	7.44	8.86	11.58	12.88	15.84	17.23	18.77	21.75	24.98	27.27					0.16	1.06	1.51	1.85		
5700	4.84	7.50	8.93	11.67	12.99	15.96	17.35	18.89	21.85	25.02	27.20					0.17	1.08	1.53	1.88		
5800	4.86	7.55	9.00	11.77	13.09	16.08	17.47	19.00	21.94	25.03	27.10					0.17	1.10	1.56	1		

POWER RATINGS

optibelt **SUPER E-POWER M=S** PROFILE **XPZ, 3VX, 9JX**

NOMINAL POWER RATING P_N [kW] FOR $\beta = 180^\circ$ AND $L_d = 1600$ mm

Table 61

Pulleys	v [m/s]	n_k [min ⁻¹]	Datum diameter of small pulley d_{dk} [mm]																Additional power [kW] per belt for speed ratio i			
			56	60	63	71	80	85	90	95	100	112	125	140	160	180	200	1.01 to 1.05	1.06 to 1.26	1.27 to 1.57	> 1.57	
Statically balanced	5	700	0.86	1.01	1.10	1.37	1.67	1.84	2.16	2.33	2.71	2.90	3.13	3.60	4.21	4.82	5.44	0.01	0.06	0.08	0.10	
		950	1.10	1.28	1.42	1.78	2.16	2.38	2.81	3.02	3.53	3.78	4.07	4.69	5.50	6.30	7.08	0.01	0.08	0.11	0.13	
		1450	1.52	1.79	1.98	2.50	3.07	3.40	4.02	4.32	5.06	5.42	5.84	6.73	7.90	9.02	10.13	0.02	0.12	0.16	0.20	
		2850	2.48	2.95	3.31	4.25	5.27	5.83	6.94	7.49	8.76	9.38	10.10	11.60	13.51	15.32	17.00	0.04	0.23	0.32	0.40	
		100	0.17	0.19	0.22	0.26	0.31	0.34	0.40	0.42	0.49	0.52	0.55	0.64	0.74	0.85	0.96	0.00	0.01	0.01	0.01	
		200	0.31	0.36	0.38	0.47	0.56	0.62	0.73	0.78	0.90	0.96	1.03	1.19	1.39	1.58	1.79	0.00	0.02	0.02	0.03	
		300	0.43	0.50	0.55	0.67	0.80	0.89	1.04	1.12	1.30	1.38	1.49	1.70	1.99	2.28	2.57	0.00	0.02	0.03	0.04	
		400	0.55	0.64	0.70	0.85	1.03	1.14	1.33	1.43	1.67	1.78	1.92	2.20	2.58	2.95	3.31	0.00	0.03	0.05	0.06	
		500	0.66	0.77	0.84	1.03	1.26	1.38	1.62	1.74	2.03	2.17	2.33	2.68	3.14	3.59	4.04	0.01	0.04	0.06	0.07	
		600	0.77	0.89	0.97	1.21	1.46	1.61	1.90	2.04	2.38	2.54	2.74	3.14	3.68	4.21	4.74	0.01	0.05	0.07	0.08	
		700	0.86	1.01	1.10	1.37	1.67	1.84	2.16	2.33	2.71	2.90	3.13	3.60	4.21	4.82	5.44	0.01	0.06	0.08	0.10	
		800	0.96	1.12	1.24	1.54	1.87	2.06	2.42	2.62	3.05	3.26	3.52	4.04	4.74	5.42	6.10	0.01	0.06	0.09	0.11	
		900	1.06	1.22	1.36	1.69	2.06	2.28	2.69	2.89	3.37	3.61	3.89	4.48	5.24	6.01	6.76	0.01	0.07	0.10	0.13	
		1000	1.15	1.33	1.48	1.85	2.26	2.48	2.94	3.16	3.70	3.95	4.26	4.91	5.75	6.58	7.40	0.01	0.08	0.11	0.14	
		1100	1.24	1.44	1.60	1.99	2.45	2.69	3.18	3.43	4.01	4.28	4.62	5.32	6.24	7.14	8.03	0.01	0.09	0.12	0.15	
		1200	1.32	1.54	1.70	2.15	2.63	2.89	3.43	3.68	4.31	4.62	4.98	5.74	6.72	7.69	8.65	0.01	0.10	0.14	0.17	
		1300	1.40	1.64	1.82	2.29	2.81	3.10	3.66	3.95	4.61	4.94	5.33	6.13	7.20	8.23	9.25	0.02	0.10	0.15	0.18	
		1400	1.49	1.74	1.93	2.44	2.99	3.29	3.90	4.20	4.91	5.27	5.68	6.54	7.66	8.76	9.84	0.02	0.11	0.16	0.19	
		1500	1.56	1.84	2.04	2.57	3.16	3.49	4.13	4.45	5.21	5.58	6.01	6.92	8.12	9.29	10.43	0.02	0.12	0.17	0.21	
		1600	1.64	1.93	2.14	2.70	3.34	3.67	4.36	4.69	5.50	5.89	6.35	7.31	8.57	9.79	10.99	0.02	0.13	0.18	0.22	
		1700	1.72	2.02	2.24	2.84	3.50	3.86	4.58	4.93	5.78	6.19	6.67	7.69	9.01	10.30	11.54	0.02	0.14	0.19	0.24	
		1800	1.79	2.11	2.34	2.98	3.67	4.04	4.80	5.17	6.06	6.49	7.00	8.06	9.44	10.79	12.08	0.02	0.14	0.20	0.25	
		1900	1.86	2.20	2.45	3.11	3.83	4.24	5.02	5.41	6.34	6.79	7.32	8.42	9.86	11.27	12.62	0.02	0.15	0.22	0.26	
		2000	1.93	2.28	2.54	3.23	4.00	4.40	5.23	5.64	6.61	7.08	7.63	8.78	10.28	11.74	13.14	0.02	0.16	0.23	0.28	
		2100	2.00	2.36	2.64	3.36	4.15	4.58	5.45	5.87	6.88	7.37	7.94	9.14	10.69	12.19	13.64	0.03	0.17	0.24	0.29	
2200	2.06	2.45	2.74	3.48	4.31	4.76	5.65	6.10	7.14	7.66	8.24	9.49	11.10	12.65	14.14	0.03	0.18	0.25	0.31			
2300	2.14	2.53	2.83	3.60	4.46	4.93	5.86	6.31	7.40	7.93	8.54	9.83	11.50	13.09	14.62	0.03	0.18	0.26	0.32			
2400	2.20	2.62	2.92	3.72	4.61	5.10	6.06	6.54	7.66	8.21	8.84	10.16	11.88	13.51	15.08	0.03	0.19	0.27	0.33			
2500	2.27	2.69	3.01	3.84	4.76	5.27	6.26	6.76	7.91	8.47	9.13	10.50	12.26	13.93	15.53	0.03	0.20	0.28	0.35			
2600	2.33	2.77	3.10	3.96	4.91	5.44	6.46	6.96	8.16	8.75	9.42	10.82	12.62	14.34	15.97	0.03	0.21	0.30	0.36			
2700	2.39	2.84	3.18	4.07	5.05	5.59	6.65	7.18	8.40	9.00	9.70	11.15	13.00	14.75	16.39	0.03	0.22	0.31	0.38			
2800	2.45	2.92	3.26	4.19	5.20	5.76	6.84	7.38	8.64	9.26	9.97	11.46	13.34	15.13	16.81	0.03	0.22	0.32	0.39			
2900	2.51	2.99	3.35	4.30	5.34	5.92	7.03	7.58	8.88	9.52	10.25	11.76	13.69	15.50	17.21	0.04	0.23	0.33	0.40			
3000	2.57	3.06	3.43	4.40	5.48	6.07	7.22	7.79	9.12	9.77	10.51	12.06	14.03	15.86	17.58	0.04	0.24	0.34	0.42			
3100	2.63	3.13	3.52	4.51	5.62	6.22	7.40	7.98	9.35	10.01	10.78	12.35	14.35	16.22	17.95	0.04	0.25	0.35	0.43			
3200	2.68	3.20	3.60	4.62	5.76	6.37	7.58	8.17	9.56	10.25	11.03	12.64	14.68	16.56	18.30	0.04	0.26	0.36	0.45			
3300	2.74	3.28	3.67	4.73	5.89	6.52	7.76	8.36	9.79	10.49	11.28	12.92	14.99	16.90	18.64	0.04	0.26	0.37	0.46			
3400	2.78	3.35	3.76	4.84	6.02	6.67	7.93	8.56	10.01	10.72	11.52	13.20	15.29	17.21	18.95	0.04	0.27	0.39	0.47			
3500	2.84	3.41	3.83	4.93	6.16	6.82	8.11	8.74	10.22	10.94	11.77	13.46	15.58	17.51	19.25	0.04	0.28	0.40	0.49			
3600	2.89	3.48	3.90	5.04	6.28	6.96	8.28	8.93	10.44	11.17	12.00	13.73	15.86	17.80	19.54	0.04	0.29	0.41	0.50			
3700	2.94	3.54	3.98	5.14	6.41	7.09	8.45	9.11	10.64	11.39	12.24	13.98	16.13	18.08	19.80	0.05	0.30	0.42	0.52			
3800	3.00	3.60	4.06	5.23	6.53	7.24	8.60	9.28	10.85	11.60	12.46	14.22	16.39	18.35	20.05	0.05	0.30	0.43	0.53			
3900	3.05	3.66	4.13	5.33	6.65	7.37	8.77	9.46	11.04	11.81	12.68	14.46	16.64	18.60	20.28	0.05	0.31	0.44	0.54			
4000	3.10	3.72	4.19	5.42	6.77	7.50	8.93	9.62	11.23	12.01	12.90	14.70	16.90	18.83	20.50	0.05	0.32	0.45	0.56			
4100	3.13	3.78	4.26	5.52	6.89	7.63	9.08	9.79	11.42	12.22	13.10	14.93	17.12	19.06	20.69	0.05	0.33	0.47	0.57			
4200	3.18	3.84	4.33	5.60	7.01	7.76	9.24	9.95	11.60	12.41	13.31	15.14	17.35	19.26	20.87	0.05	0.34	0.48	0.58			
4300	3.23	3.90	4.39	5.70	7.12	7.88	9.38	10.12	11.80	12.60	13.51	15.35	17.56	19.46	21.02	0.05	0.34	0.49	0.60			
4400	3.28	3.96	4.46	5.78	7.24	8.02	9.53	10.27	11.96	12.78	13.70	15.55	17.76	19.64	21.16	0.05	0.35	0.50	0.61			
4500	3.31	4.01	4.52	5.87	7.34	8.14	9.67	10.42	12.14	12.96	13.90	15.76	17.95	19.80	21.28	0.06	0.36	0.51	0.63			
4600	3.36	4.07	4.58	5.96	7.45	8.26	9.82	10.57	12.31	13.14	14.08	15.94	18.13	19.96	21.37	0.06	0.37	0.52	0.64			
4700	3.40	4.12	4.64	6.04	7.56	8.38	9.96	10.72	12.48	13.31	14.24	16.12	18.30	20.09	21.44	0.06	0.38	0.53	0.65			
4800	3.43	4.16	4.72	6.12	7.66	8.48	10.09	10.86	12.64	13.48	14.42	16.30	18.46	20.21	21.50	0.06	0.38	0.54	0.67			
4900	3.48	4.22	4.76	6.20	7.76	8.60	10.22	11.00	12.79	13.63	14.58	16.45	18.60	20.30	21.53	0.06	0.39	0.56	0.68			
5000	3.52	4.27	4.82	6.29	7.86	8.71	10.36	11.14	12.94	13.79	14.74	16.61	18.73	20.40	21.54	0.06	0.40	0.57	0.70			
5100	3.55	4.32	4.88	6.36	7.96	8.82	10.48	11.27	13.08	13.94	14.89	16.76	18.86	20.46	21.53	0.06	0.41	0.58	0.71			
5200	3.59	4.37	4.94	6.43	8.05	8.93	10.60	11.40	13.22	14.09	15.04	16.90	18.97	20.52	21.49	0.06	0.42	0.59	0.72			
5300	3.62	4.42	4.99	6.52	8.15	9.04	10.72	11.53	13.37	14.22	15.18	17.03	19.07	20.56		0.07	0.42	0.60	0.74			
5400	3.66	4.45	5.05	6.59	8.24	9.13	10.84	11.65	13.50	14.35	15.31	17.16	19.15	20.57		0.07	0.43	0.61	0.75			
5500	3.68	4.50	5.10	6.66	8.33	9.23	10.94	11.77	13.62	14.48	15.44	17.27	19.22	20.57		0.07	0.44	0.62	0.77			
5600	3.72	4.55	5.15	6.72	8.42	9.32	11.06	11.88	13.74	14.60	15.56	17.38	19.28	20.56		0.07	0.45	0.64	0.78			
5800	3.78	4.63	5.24	6.86	8.59	9.52	11.27	12.11	13.97	14.83	15.78	17.56	19.37	20.47		0.07	0.46	0.66	0.81			
6000	3.84	4.70	5.34	6.98	8.75	9.68	11.47	12.31														

POWER RATINGS

optibelt SUPER E-POWER M=S PROFILE XPA

NOMINAL POWER RATING P_N [kW] FOR $\beta = 180^\circ$ AND $L_d = 2500$ mm

Table 62

Pulleys	v [m/s]	n_k [min ⁻¹]	Datum diameter of small pulley d_{dk} [mm]															Additional power [kW] per belt for speed ratio i			
			71	80	85	95	100	112	118	125	140	160	180	200	224	250	280	1.01 to 1.05	1.06 to 1.26	1.27 to 1.57	> 1.57
Statically balanced	5	700	1.34	1.86	2.14	2.70	2.98	3.65	3.97	4.36	5.18	6.26	7.33	8.40	9.66	11.02	12.55	0.02	0.13	0.19	0.23
		950	1.72	2.40	2.77	3.53	3.89	4.78	5.22	5.72	6.82	8.24	9.66	11.06	12.72	14.50	16.51	0.03	0.18	0.26	0.31
		1450	2.41	3.41	3.97	5.06	5.62	6.92	7.57	8.32	9.91	12.00	14.05	16.07	18.44	20.95	23.77	0.04	0.27	0.39	0.48
		2850	3.97	5.82	6.84	8.84	9.84	12.18	13.33	14.65	17.42	20.99	24.37	27.58	31.15	34.66	38.21	0.08	0.54	0.77	0.94
		100	0.26	0.34	0.38	0.48	0.52	0.62	0.68	0.74	0.88	1.04	1.22	1.39	1.60	1.82	2.08	0.00	0.02	0.03	0.03
		200	0.47	0.62	0.72	0.89	0.97	1.18	1.28	1.40	1.66	1.99	2.33	2.65	3.05	3.47	3.96	0.01	0.04	0.05	0.07
		300	0.66	0.90	1.02	1.27	1.40	1.70	1.85	2.03	2.40	2.89	3.37	3.86	4.44	5.05	5.77	0.01	0.06	0.08	0.10
		400	0.84	1.15	1.32	1.64	1.81	2.21	2.40	2.63	3.12	3.76	4.40	5.03	5.78	6.60	7.52	0.01	0.08	0.11	0.13
		500	1.02	1.39	1.60	2.00	2.21	2.70	2.94	3.22	3.82	4.61	5.40	6.18	7.10	8.10	9.24	0.01	0.09	0.13	0.16
		600	1.19	1.63	1.87	2.35	2.59	3.18	3.46	3.79	4.50	5.45	6.37	7.30	8.39	9.56	10.91	0.02	0.11	0.16	0.20
		700	1.34	1.86	2.14	2.70	2.98	3.65	3.97	4.36	5.18	6.26	7.33	8.40	9.66	11.02	12.55	0.02	0.13	0.19	0.23
		800	1.50	2.08	2.40	3.04	3.35	4.10	4.48	4.91	5.84	7.07	8.28	9.48	10.90	12.42	14.16	0.02	0.15	0.22	0.26
		900	1.64	2.29	2.65	3.36	3.71	4.56	4.97	5.46	6.49	7.86	9.20	10.54	12.12	13.81	15.73	0.03	0.17	0.24	0.30
		1000	1.80	2.51	2.90	3.68	4.07	5.00	5.46	6.00	7.13	8.64	10.12	11.58	13.32	15.17	17.27	0.03	0.19	0.27	0.33
		1100	1.93	2.71	3.14	4.00	4.43	5.44	5.94	6.53	7.76	9.40	11.02	12.61	14.50	16.50	18.78	0.03	0.21	0.30	0.36
		1200	2.08	2.92	3.38	4.31	4.78	5.87	6.41	7.04	8.39	10.15	11.90	13.62	15.65	17.81	20.24	0.04	0.23	0.32	0.40
		1300	2.21	3.12	3.62	4.62	5.11	6.29	6.88	7.56	9.00	10.91	12.77	14.62	16.79	19.09	21.68	0.04	0.25	0.35	0.43
		1400	2.34	3.31	3.85	4.92	5.45	6.71	7.34	8.06	9.61	11.64	13.63	15.59	17.90	20.34	23.08	0.04	0.27	0.38	0.46
		1500	2.47	3.50	4.08	5.22	5.78	7.13	7.79	8.57	10.20	12.36	14.47	16.55	18.98	21.56	24.44	0.04	0.28	0.40	0.49
		1600	2.59	3.70	4.31	5.51	6.11	7.54	8.24	9.06	10.80	13.07	15.30	17.50	20.05	22.75	25.76	0.05	0.30	0.43	0.53
		1700	2.72	3.89	4.52	5.80	6.43	7.93	8.68	9.54	11.38	13.78	16.12	18.41	21.10	23.92	27.04	0.05	0.32	0.46	0.56
		1800	2.84	4.07	4.74	6.08	6.76	8.33	9.12	10.02	11.95	14.46	16.92	19.32	22.12	25.04	28.27	0.05	0.34	0.48	0.59
		1900	2.96	4.25	4.96	6.37	7.07	8.72	9.55	10.50	12.52	15.14	17.70	20.21	23.11	26.14	29.46	0.06	0.36	0.51	0.63
		2000	3.07	4.43	5.17	6.65	7.38	9.11	9.97	10.97	13.07	15.80	18.48	21.07	24.07	27.19	30.60	0.06	0.38	0.54	0.66
		2100	3.19	4.60	5.38	6.92	7.68	9.49	10.39	11.42	13.61	16.46	19.24	21.91	25.02	28.22	31.70	0.06	0.40	0.56	0.69
2200	3.30	4.78	5.58	7.19	7.98	9.86	10.80	11.88	14.15	17.11	19.97	22.74	25.93	29.21	32.75	0.06	0.42	0.59	0.73		
2300	3.41	4.94	5.78	7.45	8.28	10.24	11.21	12.32	14.68	17.74	20.70	23.54	26.82	30.16	33.74	0.07	0.44	0.62	0.76		
2400	3.52	5.11	5.99	7.72	8.57	10.61	11.60	12.77	15.20	18.36	21.41	24.34	27.67	31.07	34.68	0.07	0.45	0.65	0.79		
2500	3.62	5.27	6.18	7.97	8.86	10.97	12.00	13.20	15.71	18.97	22.09	25.09	28.50	31.94	35.57	0.07	0.47	0.67	0.82		
2600	3.72	5.44	6.37	8.23	9.14	11.32	12.38	13.62	16.21	19.56	22.76	25.84	29.29	32.77	36.40	0.08	0.49	0.70	0.86		
2700	3.83	5.59	6.56	8.48	9.42	11.66	12.77	14.04	16.70	20.15	23.42	26.54	30.06	33.56	37.16	0.08	0.51	0.73	0.89		
2800	3.92	5.75	6.74	8.72	9.70	12.01	13.14	14.45	17.20	20.71	24.06	27.24	30.79	34.31	37.87	0.08	0.53	0.75	0.92		
2900	4.02	5.90	6.94	8.96	9.97	12.35	13.51	14.86	17.66	21.26	24.68	27.90	31.49	35.00	38.52	0.08	0.55	0.78	0.96		
3000	4.12	6.05	7.12	9.20	10.24	12.67	13.87	15.25	18.13	21.80	25.28	28.55	32.16	35.65	39.11	0.09	0.57	0.81	0.99		
3100	4.20	6.19	7.28	9.44	10.50	13.01	14.23	15.64	18.59	22.33	25.86	29.16	32.78	36.25	39.62	0.09	0.59	0.83	1.02		
3200	4.30	6.34	7.46	9.67	10.76	13.32	14.58	16.02	19.03	22.85	26.42	29.76	33.38	36.82	40.07	0.09	0.61	0.86	1.05		
3300	4.38	6.48	7.63	9.90	11.02	13.63	14.92	16.39	19.46	23.34	26.96	30.31	33.94	37.32	40.45	0.10	0.63	0.89	1.09		
3400	4.46	6.62	7.80	10.12	11.26	13.94	15.25	16.76	19.88	23.82	27.49	30.85	34.45	37.76	40.75	0.10	0.64	0.91	1.12		
3500	4.55	6.76	7.97	10.34	11.51	14.24	15.59	17.11	20.29	24.29	27.98	31.36	34.93	38.16	40.99	0.10	0.66	0.94	1.15		
3600	4.63	6.89	8.12	10.55	11.75	14.54	15.91	17.47	20.70	24.74	28.46	31.84	35.36	38.51	41.15	0.11	0.68	0.97	1.19		
3700	4.70	7.02	8.28	10.76	11.98	14.83	16.22	17.81	21.08	25.18	28.92	32.28	35.77	38.80	41.22	0.11	0.70	0.99	1.22		
3800	4.79	7.15	8.44	10.97	12.20	15.12	16.52	18.14	21.47	25.60	29.35	32.70	36.12	39.02		0.11	0.72	1.02	1.25		
3900	4.86	7.27	8.59	11.17	12.43	15.40	16.82	18.47	21.83	26.00	29.77	33.10	36.43	39.19		0.11	0.74	1.05	1.29		
4000	4.93	7.39	8.74	11.36	12.66	15.66	17.12	18.78	22.19	26.39	30.16	33.44	36.71	39.30		0.12	0.76	1.08	1.32		
4100	5.00	7.51	8.88	11.56	12.88	15.92	17.40	19.09	22.54	26.76	30.52	33.77	36.92	39.35		0.12	0.78	1.10	1.35		
4200	5.06	7.63	9.02	11.75	13.08	16.18	17.68	19.38	22.86	27.11	30.85	34.06	37.10	39.34		0.12	0.80	1.13	1.38		
4300	5.14	7.74	9.16	11.93	13.28	16.43	17.95	19.67	23.18	27.44	31.16	34.31	37.24			0.13	0.81	1.16	1.42		
4400	5.20	7.85	9.30	12.11	13.49	16.68	18.22	19.96	23.48	27.76	31.45	34.54	37.32			0.13	0.83	1.18	1.45		
4500	5.26	7.96	9.43	12.29	13.68	16.91	18.47	20.22	23.78	28.06	31.72	34.72	37.36			0.13	0.85	1.21	1.48		
4600	5.32	8.06	9.55	12.46	13.87	17.14	18.71	20.48	24.06	28.33	31.96	34.87	37.34			0.13	0.87	1.24	1.52		
4700	5.38	8.16	9.67	12.62	14.05	17.36	18.95	20.74	24.32	28.58	32.16	34.98				0.14	0.89	1.26	1.55		
4800	5.42	8.26	9.80	12.78	14.23	17.58	19.18	20.98	24.59	28.82	32.34	35.06				0.14	0.91	1.29	1.58		
4900	5.47	8.35	9.91	12.94	14.41	17.78	19.39	21.20	24.83	29.04	32.50	35.10				0.14	0.93	1.32	1.62		
5000	5.52	8.45	10.03	13.09	14.57	17.99	19.61	21.42	25.04	29.23	32.62	35.10				0.15	0.95	1.34	1.65		
5100	5.57	8.53	10.14	13.24	14.74	18.17	19.81	21.64	25.26	29.41	32.71	35.05				0.15	0.97	1.37	1.68		
5200	5.62	8.62	10.25	13.38	14.89	18.36	20.00	21.84	25.45	29.57	32.77	34.98				0.15	0.98	1.40	1.71		
5300	5.66	8.70	10.34	13.51	15.05	18.53	20.18	22.02	25.64	29.70	32.81					0.16	1.00	1.42	1.75		
5400	5.70	8.78	10.44	13.64	15.19	18.70	20.36	22.20	25.81	29.82	32.82					0.16	1.02	1.45	1.78		
5500	5.74	8.86	10.54	13.78	15.32	18.86	20.52	22.37	25.96	29.90	32.78					0.16	1.04	1.48	1.81		
5600	5.77	8.93	10.63	13.90	15.46	19.01	20.68	22.52	26.10	29.98	32.72					0.16	1.06	1.51	1.85		
5700	5.81	9.00	10.72	14.00	15.59	19.15	20.82	22.67	26.22	30.02	32.64					0.17	1.08	1.53	1.88		
5800	5.83	9.06	10.80	14.12	15.71	19.30	20.96	22.80	26.33	30.04</											

POWER RATINGS

optibelt SUPER TX M=S PROFILE AX/X13

NOMINAL POWER RATING P_N [kW] FOR $\beta = 180^\circ$ AND $L_d = 1730$ mm

Table 66

Pulleys	v [m/s]	n_k [min ⁻¹]	Datum diameter of small pulley d_{dk} [mm]														Additional power [kW] per belt for speed ratio i			
			63	71	80	90	95	100	106	112	118	125	132	140	150	160	180	1.01 to 1.05	1.06 to 1.26	1.27 to 1.57
②	700	0.67	0.86	1.07	1.29	1.40	1.51	1.64	1.77	1.90	2.04	2.19	2.35	2.56	2.76	3.15	0.02	0.08	0.12	0.18
	950	0.82	1.06	1.33	1.61	1.76	1.90	2.06	2.23	2.39	2.58	2.76	2.97	3.23	3.49	3.98	0.03	0.11	0.16	0.24
	1450	1.05	1.39	1.76	2.16	2.36	2.56	2.79	3.02	3.25	3.51	3.76	4.05	4.40	4.74	5.41	0.04	0.17	0.24	0.37
	2850	1.39	1.96	2.58	3.23	3.55	3.86	4.23	4.58	4.92	5.31	5.68	6.09	6.57	7.03	7.84	0.09	0.33	0.47	0.73
	100	0.16	0.19	0.23	0.28	0.30	0.32	0.34	0.37	0.39	0.42	0.45	0.48	0.52	0.56	0.63	0.00	0.01	0.02	0.03
	200	0.27	0.34	0.41	0.49	0.52	0.56	0.61	0.65	0.70	0.75	0.80	0.86	0.93	1.00	1.14	0.01	0.02	0.03	0.05
	300	0.37	0.46	0.56	0.67	0.73	0.78	0.84	0.91	0.97	1.04	1.11	1.20	1.30	1.40	1.59	0.01	0.03	0.05	0.08
	400	0.46	0.57	0.70	0.84	0.91	0.98	1.06	1.14	1.22	1.32	1.41	1.51	1.64	1.77	2.02	0.01	0.05	0.07	0.10
	500	0.54	0.68	0.83	1.00	1.08	1.17	1.27	1.36	1.46	1.57	1.68	1.81	1.96	2.11	2.41	0.02	0.06	0.08	0.13
	600	0.61	0.77	0.95	1.15	1.25	1.34	1.46	1.57	1.68	1.81	1.94	2.09	2.27	2.44	2.79	0.02	0.07	0.10	0.15
	700	0.67	0.86	1.07	1.29	1.40	1.51	1.64	1.77	1.90	2.04	2.19	2.35	2.56	2.76	3.15	0.02	0.08	0.12	0.18
	800	0.74	0.94	1.17	1.42	1.55	1.67	1.81	1.96	2.10	2.26	2.43	2.61	2.84	3.06	3.50	0.02	0.09	0.13	0.21
	900	0.79	1.02	1.28	1.55	1.69	1.82	1.98	2.14	2.30	2.48	2.65	2.86	3.10	3.35	3.82	0.03	0.10	0.15	0.23
	1000	0.85	1.10	1.37	1.67	1.82	1.97	2.14	2.31	2.48	2.68	2.87	3.09	3.36	3.62	4.14	0.03	0.11	0.17	0.26
	1100	0.90	1.17	1.47	1.79	1.95	2.11	2.30	2.48	2.66	2.88	3.08	3.32	3.61	3.89	4.44	0.03	0.13	0.18	0.28
	1200	0.94	1.23	1.56	1.90	2.07	2.24	2.44	2.64	2.84	3.06	3.29	3.54	3.84	4.15	4.73	0.04	0.14	0.20	0.31
	1300	0.99	1.30	1.64	2.01	2.19	2.37	2.59	2.80	3.01	3.25	3.48	3.75	4.07	4.39	5.01	0.04	0.15	0.22	0.33
	1400	1.03	1.36	1.72	2.11	2.31	2.50	2.72	2.95	3.17	3.42	3.67	3.95	4.29	4.63	5.28	0.04	0.16	0.23	0.36
	1500	1.07	1.42	1.80	2.21	2.42	2.62	2.86	3.09	3.32	3.59	3.85	4.14	4.50	4.86	5.53	0.05	0.17	0.25	0.38
	⑤	1600	1.10	1.47	1.87	2.31	2.52	2.74	2.99	3.23	3.47	3.75	4.03	4.33	4.71	5.07	5.78	0.05	0.18	0.26
1700		1.14	1.52	1.95	2.40	2.63	2.85	3.11	3.37	3.62	3.91	4.19	4.51	4.90	5.28	6.01	0.05	0.20	0.28	0.44
1800		1.17	1.57	2.01	2.49	2.73	2.96	3.23	3.50	3.76	4.06	4.36	4.69	5.09	5.48	6.23	0.05	0.21	0.30	0.46
1900		1.20	1.62	2.08	2.58	2.82	3.06	3.34	3.62	3.89	4.21	4.51	4.85	5.27	5.67	6.44	0.06	0.22	0.31	0.49
2000		1.23	1.66	2.14	2.66	2.91	3.16	3.45	3.74	4.02	4.35	4.66	5.01	5.44	5.86	6.64	0.06	0.23	0.33	0.51
2100		1.25	1.71	2.20	2.74	3.00	3.26	3.56	3.86	4.15	4.48	4.80	5.17	5.60	6.03	6.83	0.06	0.24	0.35	0.54
2200		1.28	1.75	2.26	2.81	3.08	3.35	3.66	3.97	4.27	4.61	4.94	5.31	5.76	6.19	7.00	0.07	0.25	0.36	0.56
2300		1.30	1.78	2.32	2.89	3.16	3.44	3.76	4.07	4.38	4.73	5.07	5.45	5.91	6.35	7.16	0.07	0.26	0.38	0.59
2400		1.32	1.82	2.37	2.96	3.24	3.52	3.85	4.18	4.49	4.85	5.20	5.58	6.05	6.49	7.31	0.07	0.28	0.40	0.62
2500		1.34	1.85	2.42	3.02	3.32	3.60	3.94	4.27	4.59	4.96	5.32	5.71	6.18	6.63	7.45	0.08	0.29	0.41	0.64
⑩	2600	1.35	1.89	2.47	3.09	3.39	3.68	4.03	4.37	4.69	5.07	5.43	5.83	6.30	6.75	7.58	0.08	0.30	0.43	0.67
	2700	1.37	1.92	2.51	3.15	3.46	3.76	4.11	4.45	4.79	5.17	5.53	5.94	6.42	6.87	7.69	0.08	0.31	0.45	0.69
	2800	1.38	1.94	2.55	3.21	3.52	3.83	4.19	4.54	4.88	5.26	5.63	6.04	6.52	6.98	7.79	0.09	0.32	0.46	0.72
	2900	1.39	1.97	2.60	3.26	3.58	3.90	4.26	4.62	4.96	5.35	5.73	6.14	6.62	7.07	7.88	0.09	0.33	0.48	0.74
	3000	1.40	2.00	2.63	3.31	3.64	3.96	4.33	4.69	5.04	5.44	5.82	6.23	6.71	7.16	7.95	0.09	0.34	0.50	0.77
	3100	1.41	2.02	2.67	3.36	3.70	4.02	4.40	4.77	5.12	5.52	5.90	6.31	6.79	7.24	8.01	0.09	0.36	0.51	0.80
	3200	1.42	2.04	2.70	3.41	3.75	4.08	4.46	4.83	5.19	5.59	5.97	6.38	6.86	7.30	8.06	0.10	0.37	0.53	0.82
	3300	1.43	2.06	2.74	3.45	3.80	4.13	4.52	4.89	5.25	5.66	6.04	6.45	6.93	7.36	8.09	0.10	0.38	0.55	0.85
	3400	1.43	2.07	2.76	3.49	3.84	4.18	4.57	4.95	5.31	5.72	6.10	6.51	6.98	7.41	8.11	0.10	0.39	0.56	0.87
	3500	1.43	2.09	2.79	3.53	3.88	4.23	4.62	5.00	5.37	5.77	6.15	6.56	7.03	7.44	8.11	0.11	0.40	0.58	0.90
⑮	3600	1.44	2.10	2.82	3.57	3.92	4.27	4.67	5.05	5.42	5.82	6.20	6.61	7.06	7.47	8.11	0.11	0.41	0.60	0.92
	3700	1.44	2.11	2.84	3.60	3.96	4.31	4.71	5.10	5.46	5.87	6.24	6.64	7.09	7.48	8.11	0.11	0.42	0.61	0.95
	3800	1.43	2.12	2.86	3.63	3.99	4.34	4.75	5.14	5.50	5.90	6.28	6.67	7.11	7.48	8.11	0.12	0.44	0.63	0.98
	3900	1.43	2.13	2.88	3.65	4.02	4.38	4.78	5.17	5.53	5.93	6.30	6.69	7.11	7.47	8.11	0.12	0.45	0.65	1.00
	4000	1.43	2.14	2.89	3.68	4.05	4.40	4.81	5.20	5.56	5.96	6.32	6.70	7.11	7.45	8.11	0.12	0.46	0.66	1.03
	4100	1.42	2.14	2.91	3.70	4.07	4.43	4.84	5.22	5.59	5.98	6.34	6.70	7.10	7.45	8.11	0.12	0.47	0.68	1.05
	4200	1.42	2.14	2.92	3.72	4.09	4.45	4.86	5.24	5.60	5.99	6.34	6.70	7.07	7.45	8.11	0.13	0.48	0.70	1.08
	4300	1.41	2.15	2.93	3.73	4.11	4.47	4.88	5.26	5.61	6.00	6.34	6.68	7.04	7.45	8.11	0.13	0.49	0.71	1.10
	4400	1.40	2.14	2.93	3.74	4.12	4.48	4.89	5.27	5.62	6.00	6.33	6.66	7.00	7.45	8.11	0.13	0.51	0.73	1.13
	4500	1.39	2.14	2.94	3.75	4.13	4.49	4.90	5.27	5.62	5.99	6.31	6.63	6.94	7.45	8.11	0.14	0.52	0.74	1.15
⑳	4600	1.37	2.14	2.94	3.76	4.14	4.49	4.90	5.27	5.61	5.97	6.29	6.63	7.00	7.45	8.11	0.14	0.53	0.76	1.18
	4700	1.36	2.13	2.94	3.76	4.14	4.50	4.90	5.27	5.60	5.95	6.25	6.59	7.00	7.45	8.11	0.14	0.54	0.78	1.21
	4800	1.34	2.12	2.94	3.76	4.14	4.49	4.89	5.26	5.59	5.92	6.21	6.56	7.00	7.45	8.11	0.15	0.55	0.79	1.23
	4900	1.33	2.11	2.93	3.76	4.13	4.49	4.88	5.24	5.56	5.89	6.16	6.51	7.00	7.45	8.11	0.15	0.56	0.81	1.26
	5000	1.31	2.10	2.92	3.75	4.13	4.48	4.87	5.22	5.53	5.85	6.11	6.46	7.00	7.45	8.11	0.15	0.57	0.83	1.28
	5100	1.29	2.09	2.91	3.74	4.11	4.46	4.85	5.19	5.50	5.82	6.08	6.43	6.90	7.45	8.11	0.16	0.59	0.84	1.31
	5200	1.27	2.07	2.90	3.73	4.10	4.45	4.82	5.16	5.46	5.78	6.04	6.39	6.90	7.45	8.11	0.16	0.60	0.86	1.33
	5300	1.25	2.05	2.89	3.71	4.08	4.42	4.79	5.12	5.41	5.73	6.00	6.35	6.90	7.45	8.11	0.16	0.61	0.88	1.36
	5400	1.22	2.04	2.87	3.69	4.06	4.40	4.76	5.08	5.35	5.67	5.94	6.30	6.80	7.45	8.11	0.16	0.62	0.89	1.39
	5500	1.20	2.01	2.85	3.67	4.03	4.37	4.72	5.03	5.29	5.61	5.88	6.24	6.70	7.45	8.11	0.17	0.63	0.91	1.41
㉑	5600	1.17	1.99	2.83	3.64	4.00	4.33	4.68	5.00	5.32	5.64	5.96	6.31	6.80	7.45	8.11	0.17	0.64	0.93	1.44
	5700	1.14	1.97	2.80	3.61	3.97	4.29	4.63	4.95	5.27	5.59	5.91	6.26	6.70	7.45	8.11	0.17	0.65	0.94	1.46
	5800	1.11	1.94	2.78	3.58	3.93	4.25	4.58	4.90	5.22	5.54	5.86	6.21	6.60	7.45	8.11	0.18	0.67	0.96	1.49
	5900	1.08	1.91	2.75	3.55	3.89	4.20	4.52	4.84	5.16	5.48									

POWER RATINGS

optibelt SUPER TX M=S PROFILE CX/X22

NOMINAL POWER RATING P_N [kW] FOR $\beta = 180^\circ$ AND $L_d = 3808$ mm

Table 68

Pulleys	v [m/s]	n_k [min ⁻¹]	Datum diameter of small pulley d_{dk} [mm]														Additional power [kW] per belt for speed ratio i					
			140	150	160	180	200	224	250	280	315	335	355	400	450	500	630	1.01 to 1.05	1.06 to 1.26	1.27 to 1.57	> 1.57	
Statically balanced	5	700	4.81	5.29	5.76	6.69	7.59	8.65	9.77	11.03	12.45	13.24	14.02	15.70	17.48	19.17	23.07	0.06	0.23	0.33	0.52	
		950	6.07	6.68	7.28	8.46	9.61	10.94	12.34	13.89	15.62	16.58	17.50	19.46	21.47	23.28	26.99	0.08	0.32	0.45	0.70	
		1450	8.23	9.07	9.89	11.49	13.01	14.76	16.54	18.44	20.47	21.52	22.50	24.39	25.99	27.00	26.57	0.13	0.48	0.69	1.07	
		2850	12.16	13.34	14.45	16.45	18.14	19.73	20.88	21.39	20.80								0.25	0.95	1.36	2.11
		50	0.54	0.59	0.64	0.74	0.83	0.94	1.06	1.20	1.35	1.44	1.53	1.72	1.94	2.15	2.69	0.00	0.02	0.02	0.04	
		100	0.98	1.07	1.16	1.34	1.51	1.72	1.94	2.19	2.47	2.63	2.79	3.15	3.54	3.93	4.90	0.01	0.03	0.05	0.07	
		150	1.38	1.51	1.64	1.89	2.14	2.43	2.74	3.09	3.50	3.73	3.96	4.46	5.01	5.56	6.93	0.01	0.05	0.07	0.11	
		200	1.76	1.92	2.08	2.41	2.72	3.10	3.50	3.95	4.47	4.76	5.06	5.70	6.40	7.09	8.83	0.02	0.07	0.10	0.15	
		250	2.11	2.31	2.51	2.90	3.28	3.74	4.22	4.77	5.40	5.75	6.10	6.88	7.72	8.55	10.62	0.02	0.08	0.12	0.19	
		300	2.45	2.69	2.92	3.37	3.82	4.35	4.91	5.55	6.29	6.70	7.10	8.00	8.98	9.94	12.33	0.03	0.10	0.14	0.22	
		350	2.78	3.05	3.31	3.83	4.34	4.94	5.59	6.31	7.14	7.61	8.07	9.09	10.19	11.27	13.95	0.03	0.12	0.17	0.26	
		400	3.10	3.39	3.69	4.27	4.84	5.52	6.23	7.05	7.97	8.49	9.00	10.14	11.36	12.55	15.49	0.04	0.13	0.19	0.30	
		450	3.40	3.73	4.06	4.70	5.33	6.08	6.86	7.76	8.75	9.34	9.91	11.15	12.48	13.78	16.96	0.04	0.15	0.22	0.33	
		500	3.70	4.06	4.42	5.12	5.81	6.62	7.48	8.45	9.55	10.17	10.78	12.12	13.56	14.95	18.34	0.04	0.17	0.24	0.37	
		550	3.99	4.38	4.76	5.52	6.27	7.15	8.07	9.12	10.31	10.97	11.63	13.07	14.60	16.08	19.65	0.05	0.18	0.26	0.41	
		600	4.27	4.69	5.10	5.92	6.72	7.66	8.65	9.77	11.04	11.75	12.45	13.98	15.60	17.16	20.87	0.05	0.20	0.29	0.44	
		650	4.55	4.99	5.44	6.31	7.16	8.16	9.22	10.41	11.76	12.51	13.25	14.86	16.56	18.19	22.02	0.06	0.22	0.31	0.48	
		700	4.81	5.29	5.76	6.69	7.59	8.65	9.77	11.03	12.45	13.24	14.02	15.70	17.48	19.17	23.07	0.06	0.23	0.33	0.52	
		750	5.08	5.58	6.08	7.06	8.01	9.13	10.31	11.64	13.13	13.95	14.76	16.52	18.36	20.10	24.04	0.07	0.25	0.36	0.56	
		800	5.33	5.86	6.39	7.42	8.42	9.60	10.84	12.22	13.78	14.64	15.48	17.30	19.20	20.97	24.93	0.07	0.27	0.38	0.59	
		850	5.58	6.14	6.69	7.77	8.83	10.06	11.35	12.80	14.41	15.31	16.18	18.06	20.00	21.80	25.71	0.07	0.28	0.41	0.63	
		900	5.83	6.42	6.99	8.12	9.22	10.50	11.85	13.35	15.03	15.95	16.85	18.78	20.76	22.57	26.40	0.08	0.30	0.43	0.67	
		950	6.07	6.68	7.28	8.46	9.61	10.94	12.34	13.89	15.62	16.58	17.50	19.46	21.47	23.28	26.99	0.08	0.32	0.45	0.70	
		1000	6.31	6.94	7.57	8.79	9.98	11.37	12.82	14.42	16.20	17.17	18.12	20.12	22.14	23.94	27.48	0.09	0.33	0.48	0.74	
		1050	6.54	7.20	7.85	9.12	10.35	11.78	13.28	14.93	16.76	17.75	18.71	20.74	22.76	24.53	27.86	0.09	0.35	0.50	0.78	
		1100	6.77	7.45	8.12	9.44	10.71	12.19	13.73	15.42	17.29	18.31	19.28	21.32	23.34	25.07	28.13	0.10	0.36	0.53	0.82	
		1150	6.99	7.70	8.39	9.75	11.06	12.59	14.17	15.90	17.81	18.84	19.82	21.87	23.87	25.55	28.28	0.10	0.38	0.55	0.85	
		1200	7.21	7.94	8.66	10.06	11.41	12.97	14.59	16.37	18.30	19.35	20.34	22.39	24.35	25.96	28.31	0.11	0.40	0.57	0.89	
		1250	7.42	8.17	8.91	10.35	11.75	13.35	15.01	16.81	18.78	19.83	20.83	22.87	24.78	26.31	28.23	0.11	0.41	0.60	0.93	
		1300	7.63	8.40	9.17	10.65	12.07	13.72	15.41	17.25	19.23	20.29	21.29	23.31	25.16			0.11	0.43	0.62	0.96	
1350	7.83	8.63	9.41	10.93	12.39	14.07	15.80	17.66	19.67	20.73	21.72	23.71	25.49			0.12	0.45	0.65	1.00			
1400	8.04	8.85	9.66	11.21	12.71	14.42	16.17	18.06	20.08	21.14	22.12	24.07	25.77			0.12	0.46	0.67	1.04			
1450	8.23	9.07	9.89	11.49	13.01	14.76	16.54	18.44	20.47	21.52	22.50	24.39	25.99			0.13	0.48	0.69	1.07			
1500	8.43	9.28	10.12	11.75	13.31	15.08	16.89	18.81	20.83	21.88	22.84	24.67	26.15			0.13	0.50	0.72	1.11			
1550	8.61	9.49	10.35	12.01	13.60	15.40	17.22	19.16	21.18	22.21	23.15	24.91				0.14	0.51	0.74	1.15			
1600	8.80	9.70	10.57	12.27	13.88	15.71	17.55	19.49	21.50	22.52	23.43	25.11				0.14	0.53	0.77	1.19			
1650	8.98	9.90	10.79	12.51	14.15	16.00	17.86	19.81	21.80	22.80	23.68	25.27				0.15	0.55	0.79	1.22			
1700	9.16	10.09	11.00	12.76	14.42	16.29	18.16	20.11	22.07	23.05	23.90	25.37				0.15	0.56	0.81	1.26			
1750	9.33	10.28	11.21	12.99	14.68	16.56	18.44	20.38	22.33	23.27	24.09	25.44				0.15	0.58	0.84	1.30			
1800	9.50	10.47	11.41	13.22	14.92	16.83	18.71	20.65	22.55	23.46						0.16	0.60	0.86	1.33			
1850	9.67	10.65	11.61	13.44	15.16	17.08	18.97	20.89	22.75	23.63						0.16	0.61	0.88	1.37			
1900	9.83	10.83	11.80	13.66	15.40	17.33	19.21	21.11	22.93	23.76						0.17	0.63	0.91	1.41			
1950	9.99	11.00	11.99	13.87	15.62	17.56	19.44	21.32	23.08	23.86						0.17	0.65	0.93	1.45			
2000	10.14	11.17	12.17	14.07	15.84	17.78	19.66	21.50	23.20	23.93						0.18	0.66	0.96	1.48			
2050	10.29	11.33	12.34	14.26	16.04	17.99	19.86	21.67	23.30							0.18	0.68	0.98	1.52			
2100	10.44	11.49	12.52	14.45	16.24	18.19	20.04	21.81	23.37							0.18	0.70	1.00	1.56			
2150	10.58	11.65	12.68	14.64	16.43	18.38	20.21	21.94	23.41							0.19	0.71	1.03	1.59			
2200	10.72	11.80	12.84	14.81	16.62	18.56	20.36	22.05	23.42							0.19	0.73	1.05	1.63			
2250	10.85	11.95	13.00	14.98	16.79	18.72	20.50	22.13	23.40							0.20	0.75	1.08	1.67			
2300	10.98	12.09	13.15	15.14	16.95	18.87	20.63	22.19								0.20	0.76	1.10	1.70			
2350	11.11	12.22	13.29	15.30	17.11	19.01	20.73	22.23								0.21	0.78	1.12	1.74			
2400	11.23	12.36	13.43	15.44	17.25	19.14	20.82	22.25								0.21	0.80	1.15	1.78			
2450	11.35	12.48	13.57	15.58	17.39	19.26	20.90	22.25								0.22	0.81	1.17	1.82			
2500	11.47	12.61	13.70	15.72	17.52	19.36	20.96	22.23								0.22	0.83	1.20	1.85			
2550	11.58	12.73	13.82	15.84	17.63	19.45	21.00									0.22	0.85	1.22	1.89			
2600	11.68	12.84	13.94	15.96	17.74	19.53	21.02									0.23	0.86	1.24	1.93			
2650	11.79	12.95	14.05	16.08	17.84	19.60	21.03									0.23	0.88	1.27	1.96			
2700	11.89	13.05	14.16	16.18	17.93	19.65	21.02									0.24	0.90	1.29	2.00			
2750	11.98	13.15	14.26	16.28	18.01	19.69	20.99									0.24	0.91	1.32	2.04			
2800	12.07	13.25	14.36	16.37	18.08	19.72										0.25	0.93	1.34	2.08			
2850	12.16	13.34	14.45	16.45	18.14	19.73										0.25	0.95	1.36	2.11			
2900	12.24	13.42	14.53	16.52	18.19	19.73										0.26	0.96	1.39	2.15			
2950	12.32	13.50	14.61	16.59	18.23	19.72										0.26	0.98	1.41	2.19			
3000	12.39	13.58	14.68	16.65	18.26	19.69										0.26	0.99	1.43	2.22			
3050	12.46	13.65	14.75	16.70	18.27											0.27	1.01	1.46	2.26			
3100	12.53	13.71	14.81	16.74	18.28											0.27	1.03	1.48	2.30			
3150	12.59</																					

SPECIAL DRIVES

V-FLAT DRIVES

The V-flat drive comprises one grooved pulley and one flat pulley. This type of gear can, under certain conditions, be used for drives with intermittent loading or with large moments of inertia. As flywheels or flat pulleys are often

already present, the costs of the drive can be reduced. When changing over a flat belt drive to a V-flat drive, it will usually be economical to continue to use the flat pulley.

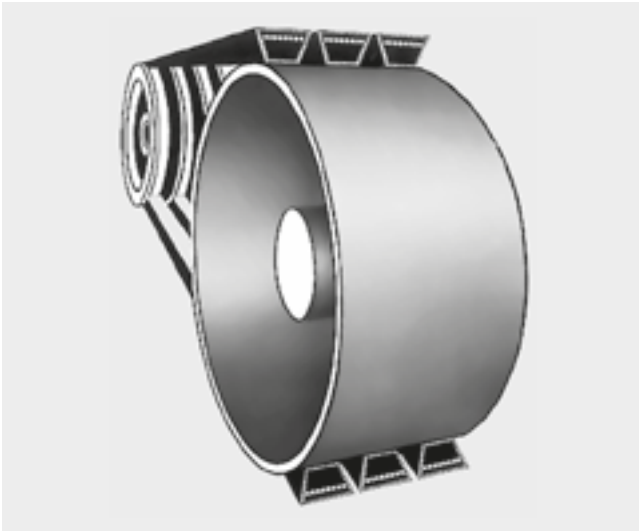

- a = drive centre distance [mm]
- b = face width of the flat pulley [mm]
- b_v = bottom width of the belt [mm]
- b_2 = face width of the grooved pulley [mm]
- D_a = outside diameter of the flat pulley [mm]
- D_Z = correction factor for determination of the theoretical diameter [mm]
- d_a = outside diameter of the grooved pulley [mm]
- d_d = datum diameter of the grooved pulley [mm]
- F_f = contact area of V-belt and flat pulley [cm²]
- f = correction factor for calculating the face width of the flat pulley [mm]
- h = height of crown per 100 mm pulley face width [mm]
- i = speed ratio
- L_{ath} = calculated outside length of the kraftband [mm]
- L_{dth} = calculated datum length of the V-belt [mm]
- p_f = specific surface pressure [N/cm²]
- P = power to be transmitted by the belt drive [kW]
- S_n = circumferential force [N]
- α = arc of contact on the flat pulley = $360^\circ - \beta$ (°)
- k_f = factor
datum length $L_d \hat{=} \text{pitch length } L_w$

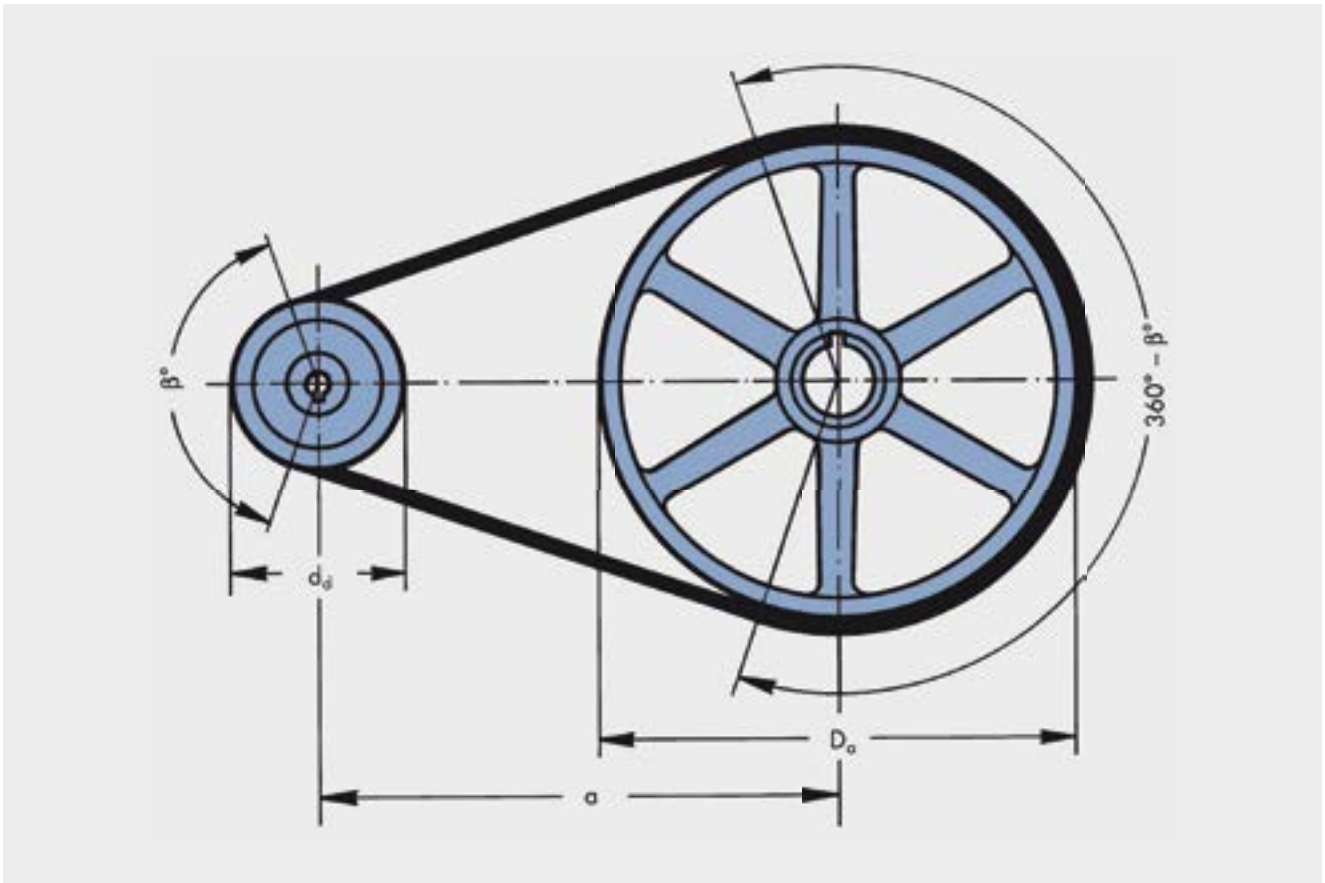

SPECIAL DRIVES

V-FLAT DRIVES

Calculating V-flat drives

The calculation of V-flat drives is based on the same method as presented on pages 85 to 87. In order to ensure reliability and efficiency, the V-flat belt drive must meet the following requirements:

- The small pulley must always be V-grooved.
- When using single belts, only classic V-belts in profiles Z/10, A/13, B/17, C/22, D/32, E/40 must be used.
- Wedge belts must never be used as their narrow base and larger relative height tends to make them turn and twist.
- All optibelt KB kraftbands – both with wedge belts and classic V-belts – are particularly suitable for this type of drive due to their single belt characteristic. Turning over even under extreme shock load conditions is prevented.
- A V-flat drive is particularly economic when

$$kf = \frac{D_a - d_d}{a} \text{ is between } 0.5 \text{ and } 1.15$$

The optimum drive dimensioning is achieved when $kf = 0.85$. If the factor kf is outside the recommended range, it is more economical to design a standard V-belt drive.

- The following recommendations result from these requirements:

	Classic V-belts	Kraftbands
Speed ratio	$i = \frac{D_a + D_z}{d_d} \geq 3$	$i = \frac{D_a + D_z}{d_a} \geq 3$
Centre distance	$a_{zul} \geq D_a$	$a_{zul} \geq D_a$
	$a = \frac{D_a - d_d}{0.85}$	$a = \frac{D_a - d_a}{0.85}$
kf factor	$kf = \frac{D_a - d_d}{a}$	$kf = \frac{D_a - d_a}{a}$
	$0.5 \leq kf_{zul} \leq 1.15$	

- When calculating the number of belts and the belt tension, it should be noted that a special arc of contact factor c_1 must be used as shown in the following table.

Table 69: Arc of contact factor c_1 (only for V-flat drives)

$kf = \frac{D_a - d_d}{a}$	$\beta =$	c_1
0	180°	0.75
0.07	176°	0.76
0.15	170°	0.77
0.22	167°	0.79
0.29	163°	0.79
0.35	163°	0.79
0.40	156°	0.81
0.45	153°	0.81
0.50	150°	0.82
0.57	146°	0.83
0.64	143°	0.84
0.70	140°	0.85
0.75	137°	0.85
0.80	134°	0.86
0.85	130°	0.86
0.92	125°	0.84
1.00	120°	0.82
1.07	115°	0.80
1.15	110°	0.78
1.21	106°	0.77
1.30	100°	0.73
1.36	96°	0.72
1.45	90°	0.70

- For classic V-belts, the length is calculated using the datum length L_d , and for kraftbands using the outside length L_a . Therefore, the correction factor D_z must be added to the outside diameter of the flat pulley in order to approximate the theoretical design diameter.

Correction factor D_z for determination of the theoretical design diameter

Classic V-belts

Profile	Z/10	A/13	B/17	C/22	D/32	E/40
D_z mm	7	10	13	18	23	25

Kraftbands

Profile	3V/9J	5V/15J	8V/25J	SPZ	SPA	SPB	SPC	A/HA	B/HB	C/HC	D/HD
D_z mm	13	23	41	12	15	19	26	12	20	24	35

Calculation of the datum length for Classic V-belts

$$L_{dth} \approx 2a + 1.57 (d_d + D_a + D_z) + \frac{(D_a + D_z - d_d)^2}{4a}$$

Calculation of the outside length for kraftbands

$$L_{ath} \approx 2a + 1.57 (d_a + D_a + D_z) + \frac{(D_a + D_z - d_a)^2}{4a}$$

Length conversion factors are given on pages 161/162. Datum length $L_d \triangleq$ pitch length L_w

SPECIAL DRIVES

V-FLAT DRIVES

- The flat pulley should be shaped cylindrically. With existing flat pulleys that are re-used for the V-flat belt drive, the height of the crown should be checked.

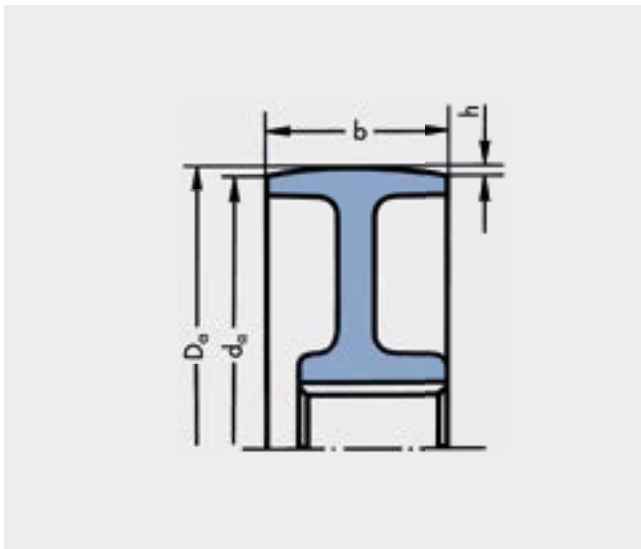

The following conditions must be met:

Maximum crown height

$h_{max} = 1 \text{ mm per } 100 \text{ mm pulley face width}$

$$h = \frac{D_a - d_a}{2} \quad (h < h_{max})$$

In addition, the pulley face width must be calculated or checked as shown in the following example:

Given/Calculated:

V-grooved pulley 6 grooves
 Profile B/17
 Drive centre distance a 850 mm

Solution:

$$b = b_2 + f$$

$$b = 120 + 35 = \mathbf{155 \text{ mm}}$$

b_2 for classic V-belts, page 51, table 14.

b_2 for kraftbands, page 55, table 20

f from table 70.

Selected standard flat pulley according to DIN 111 with crown width $b = \mathbf{160 \text{ mm}}$

Table 70: Additional factor f for determining the crown width of the flat pulley

Z/10, SPZ, A/13/HA, 3V/9J		SPB, 5V/15J		C/22/HC, SPC		D/32/HD, 8V/25J		E/40	
a	f	a	f	a	f	a	f	a	f
< 500	20	< 750	25	< 1000	30	< 1250	40	< 1750	45
500-750	25	750-1000	35	1000-1250	40	1250-1750	50	1750-2250	60
> 750	30	> 1000	40	> 1250	50	> 1750	65	> 2250	75

Calculation of the specific surface pressure on the flat pulley

Calculation of the effective belt tension S_n [N]

$$S_n = \frac{P \cdot 1000}{v}$$

Surface pressure on flat pulley p_f [N/cm²]*

$$p_f = \frac{S_n}{F_1}$$

Area of belt contact on flat pulley F_1 [cm²]

$$F_1 = \frac{D_a \cdot \pi \cdot \alpha \cdot b_u \cdot z}{36000}$$

Recommended surface pressure p_f [N/cm²]*

$$p_f \leq 4 \text{ N/cm}^2*$$

* $10 \text{ N/cm}^2 = 1 \text{ Bar} = 10^5 \text{ Pascal}$

Formula:

Calculation of the static belt tension for V-flat belt drives T [N]

$$T = \frac{500 \cdot (2.25 - c_1) \cdot P_B}{c_1 \cdot z \cdot v} + k \cdot v^2$$

In addition to the calculation method on pages 85 to 87 the static belt tension for V-flat drives must be calculated according to the formulae given here.

SPECIAL DRIVES

TENSION/GUIDE IDLERS

Idlers are grooved or flat pulleys that do not transmit any power in a drive system. Due to the fact that additional flexing stress is created in the belt, it is recommended that idlers are only used sparingly under the following conditions if possible:

- with fixed drive centres in order to produce the required tension and to take up the maximum possible belt stretch and wear,
- as an idler pulley when dealing with extremely long free belt spans that are subject to twisting,
- as outside idlers where the arc of contact on one of the loaded pulleys is too low. Their inclusion increases the arc of contact and often reduces excessive slip or eliminates the need to increase the number of belts,
- as idler pulleys and guide idlers on drives where pulleys are not all on the same plane such as quarter turn drives,
- to guide belts past obstructions,
- as pneumatically, hydraulically or spring loaded idlers to maintain a constant tension,
- as clutching idlers with which the driven pulley can be engaged or disengaged. Complex clutches are no longer required. Because of their single belt characteristics, optibelt KB kraftbands are particularly suited for these applications.

If, for the reasons listed above, it is absolutely essential to employ idlers, the following criteria should be considered when designing the drive:

- idler configuration
- position of the idler in the belt span
- idler diameter
- idler design
- adjustment allowance of the idler for installation and initial and subsequent tensioning of the belt
- correction of the power rating P_N

Idler configuration

In principle, idlers can be used as inside or outside idlers depending on the drive situation. Unless design requirements call for an outside idler, the inside idler is usually more advantageous. Its diameter can be kept smaller than that of the outside idler.

Depending on the belt type, **inside idlers** can either be grooved or flat pulleys.

Table 71: Profile dimensions

Belt type	V-grooved pulley	Flat pulley
High performance wedge belts DIN 7753 Part 1 SPZ; SPA; SPB; SPC	•	
High performance wedge belts USA standard RMA/MPTA 3V/9N; 5V/15N; 8V/25N	•	
Classic V-belts DIN 2215 Z/10; A/13; B/17; 20; C/22; 25; D/32; E/40	•	•
Kraftbands with high performance wedge belts 3V/9J; 5V/15J; 8V/25J; SPA; SPZ; SPB; SPC	•	•
Kraftbands with classic V-belts A/HA; B/HB; C/HC; D/HD	•	•

For raw edge V-belts and kraftbands the same requirements as given in table 71 apply.

Inside idlers reduce the arc of contact on the loaded pulleys and with it the arc of contact correction factor c_1 . When calculating the number of belts, the arc of contact correction factor should be selected for the position of the idler at the point of maximum belt stretch (see table 73, page 131).

Outside idlers generally have to be flat pulleys as they are running on the back of the belt. They increase the arc of contact. Care must be taken to ensure that the maximum possible belt stretch is taken up and that contact with the opposite span is prevented. The reverse bending caused by outside idlers will lead to a reduction of the belt service life.

Special V-belt constructions on request.

SPECIAL DRIVES

TENSION/GUIDE IDLERS

Position of the idler in the belt span

Theoretical power transmission formulas and actual practice have shown that idlers should, wherever possible, be placed in the slack side of the drive. The tension idler force can be reduced very significantly then. A spring loaded idler must not be employed in a reversing drive as the slack and tight sides of the drive are constantly changing. Our Application Engineering Department will be pleased to assist you when spring loaded idlers present special problems.

Fig. 1

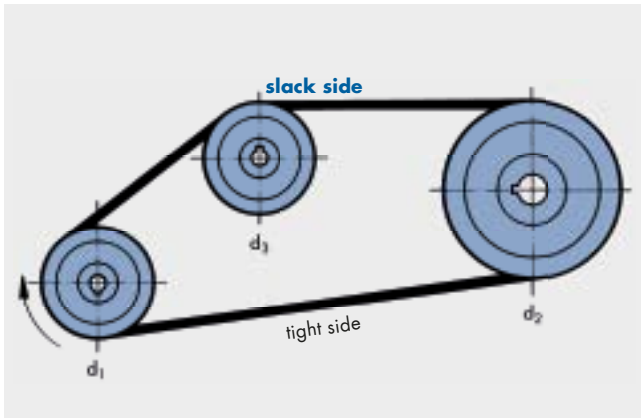

Grooved pulleys can be used as inside idlers anywhere on the slack side. Where possible, however, the arc of contact should be the same on both pulleys when the idler reaches its end position, i.e. belt stretch is at its maximum.

Fig. 2

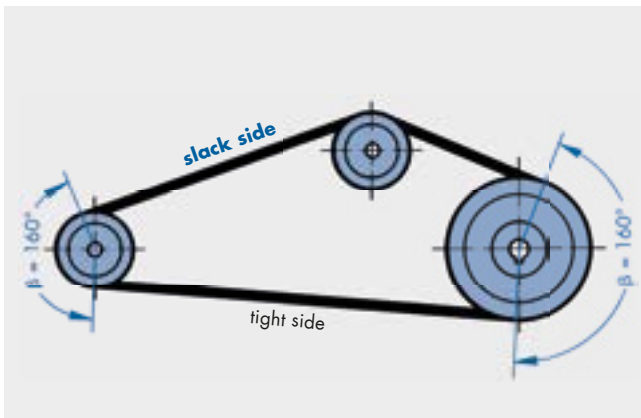

Flat pulleys, whether used as inside or outside idlers, are to be placed as far as possible away from the grooved pulley on to which the belt runs next. Any alignment errors between the idler and the pulley and the resultant sideways movement of the belt on the pulley are thus avoided.

Fig. 3

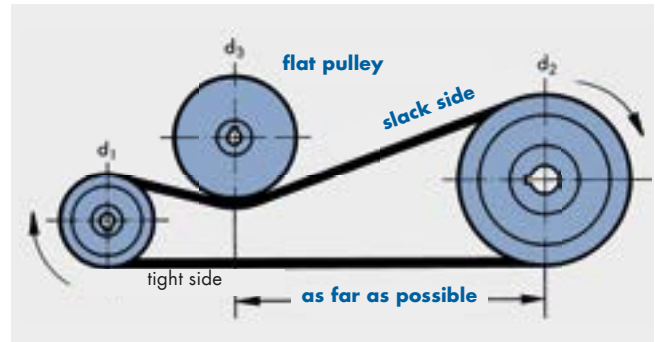

On drives with long belt spans, grooved pulleys are the preferred choice for inside idlers because with flat pulleys transverse vibrations and belt turnover can occur.

Minimum diameter for inside idlers

Inside idler > smallest loaded pulley in the drive system

Minimum diameter for outside idlers

Outside idler > 1.35 x smallest loaded pulley in the drive system

Exceptions:

Profile	Diameter of the smallest pulley in the drive [mm]	Minimum diameter of the outside idler [mm]
Z/10	56- 63	90
A/13	71- 90	125
SPZ, 3V/9N	63- 90	125
SPA	90-112	150

The belt service life is significantly reduced if the minimum recommended idler diameter is less than the recommended size. The use of an OPTIBELT special construction can significantly improve service life.

Idler design

Grooved pulleys which are used as idlers can usually have standard pulley dimensions. On drives with too severe vibration and long drive centre distances, it is recommended that deep grooved pulleys are used.

Flat pulleys should, if possible, be cylindrical and not crowned. Flanged pulleys are recommended as belt guides. The edges formed by the contact surface and pulley flange should be sharp. Round edges encourage the belt to run on the flanges causing it to turn over.

SPECIAL DRIVES

TENSION/GUIDE IDLERS

The face width or the contact surface between the two flanges is calculated as follows:

$$b = b_2 + m$$

b = face width/contact surface [mm]

b₂ = face width of the grooved pulley [mm]

m = additional value [mm]

Profile	Additional value m [mm]
SPZ, 3V/9N, Z/10	15
SPA, A/13	20
SPB, 5V/15N, B/17	25
SPC, C/22	30
8V/25N	35
D/32	40
E/40	45

This also applies to raw edge V-belts

Drive calculation

Calculating the length and determining the number of belts is basically the same as for 2-pulley drives. Certain details are, however, to be noted:

1. Calculate the belt length over two pulleys using the formula: see notes on standards page 172.

$$L_{dth} \approx 2a + 1.57 (d_{dg} + d_{dk}) + \frac{(d_{dg} - d_{dk})^2}{4a}$$

2. As the belt has to be fitted without force with fixed centre distances, the double adjustment y must be added to the belt length L_{dth} (see pages 82/83).

$$L_d = L_{dth} + 2 y$$

3. The next largest standard length L_{dSt} should then be selected. A check should be made, usually on the drawing, to determine whether the belt can be adequately tensioned with the idler in the outermost position. In this idler position, both the standard length L_{dSt} and the double adjustment x must be taken up (see pages 82/83).

$$L_d \text{ for idler end position} = L_{dSt} + 2 x$$

Fig. 4

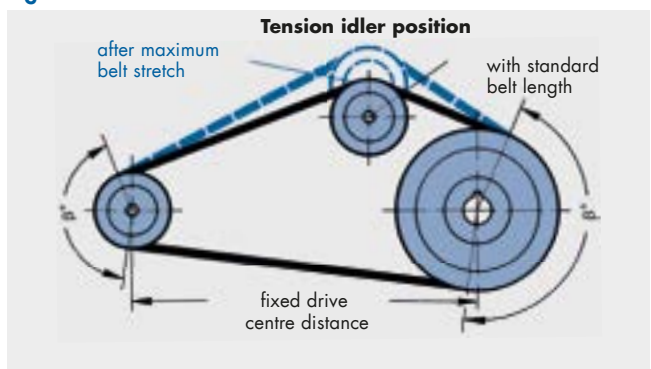

Number of belts

The use of idlers increases the bending stress in the belts. To avoid a reduction in belt service life, the idler correction factor c₄ must also be included in the calculation. This correction factor takes into account the number of idlers that are larger than the minimum diameter.

Table 72

Number of idlers	c ₄
0	1.00
1	0.91
2	0.86
3	0.81

The nominal power rating P_N per belt is, as before, based on the smallest loaded pulley.

Calculation of the arc of contact correction factor c₁ must be based on the smallest contact angle of the loaded pulley which occurs when the belt is stretched to its maximum limit.

Table 73: Arc of contact correction factor c₁

β =	c ₁	β =	c ₁
75°	0.82	175°	1.00
80°	0.84	180°	1.00
85°	0.86	185°	1.00
90°	0.88	190°	1.00
95°	0.90	195°	1.01
100°	0.91	200°	1.01
105°	0.92	205°	1.01
110°	0.93	210°	1.01
115°	0.94	215°	1.01
120°	0.95	220°	1.01
125°	0.96	225°	1.01
130°	0.96	230°	1.01
135°	0.97	240°	1.02
140°	0.97	250°	1.02
145°	0.98		
150°	0.98		
155°	0.99		
160°	0.99		
165°	0.99		
170°	1.00		

The following formula for determining the number of belts is obtained using the idler correction factor c₄:

$$z = \frac{P \cdot c_2}{P_N \cdot c_1 \cdot c_3 \cdot c_4}$$

SPECIAL DRIVES

TWIST DRIVES

Drives with crossing belt spans are often simply termed twist drives. These can be drives where the shafts are not parallel, whose pulleys and idlers are not all arranged on one plane, or drives with two parallel but counter rotating shafts. Because of the twisting of the belt, this type of drive requires a certain degree of lateral bending flexibility. Due to the cross section of V-belts, flat belts are better suited for this application. In most cases twist drives use single V-belts, but drives using belt sets are also possible. The crossing of the belt spans and the non-aligned entry of the belt into the pulley leads to a reduction of the belt service life. The entry and exit angle between the belt and the pulley plane should not be more than 5° .

The required inclination of the shafts and the pulleys relative to each other and the belt entry and exit angles should be confirmed by practical tests. In addition, certain critical drives may have a considerably improved safety factor if special constructions by OPTIBELT are used. The most important types of twist drives and the according design guidelines are illustrated below.

Quarter twist drive

The term quarter twist drive is used to describe systems where the shafts are at an angle of 90° to each other. The ratio i or $1 : i$ of quarter twist drives should not exceed 2.5.

Where this is not possible, a two stage drive should be employed, in which one stage is a standard V-belt drive.

Quarter twist drive – ratio i or $1 : i < 2.5$

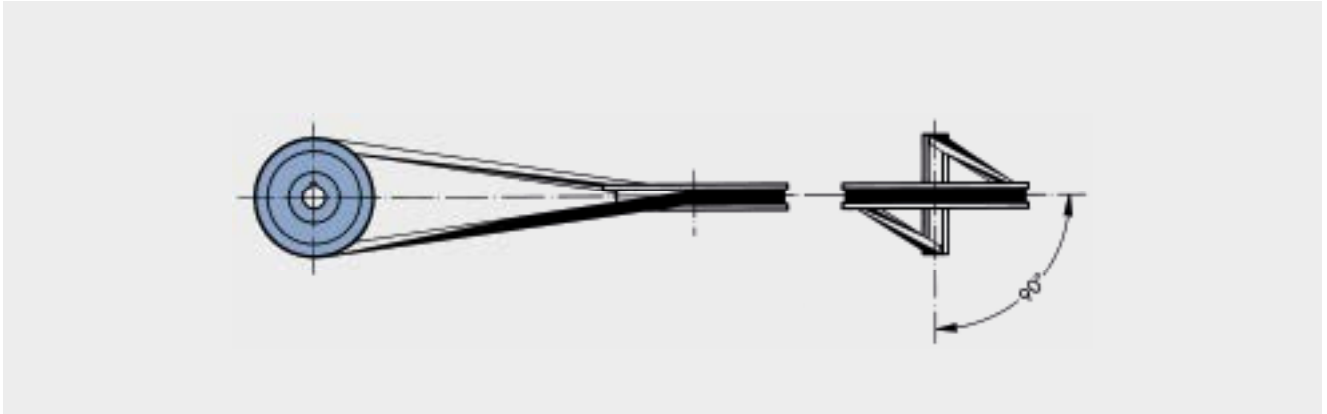

Quarter twist drive – ratio i or $1 : i > 2.5$

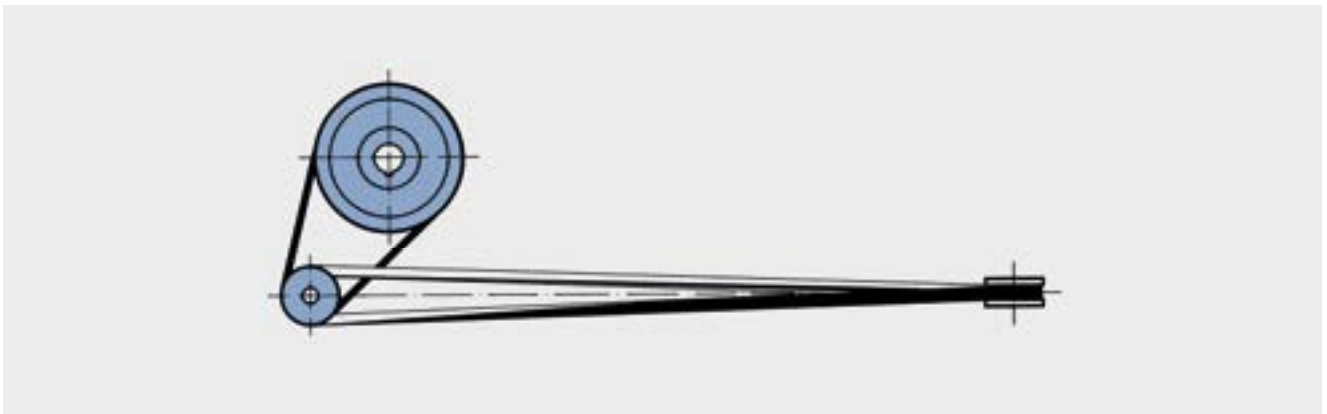

SPECIAL DRIVES

TWIST DRIVES

Design guidelines for quarter twist drives

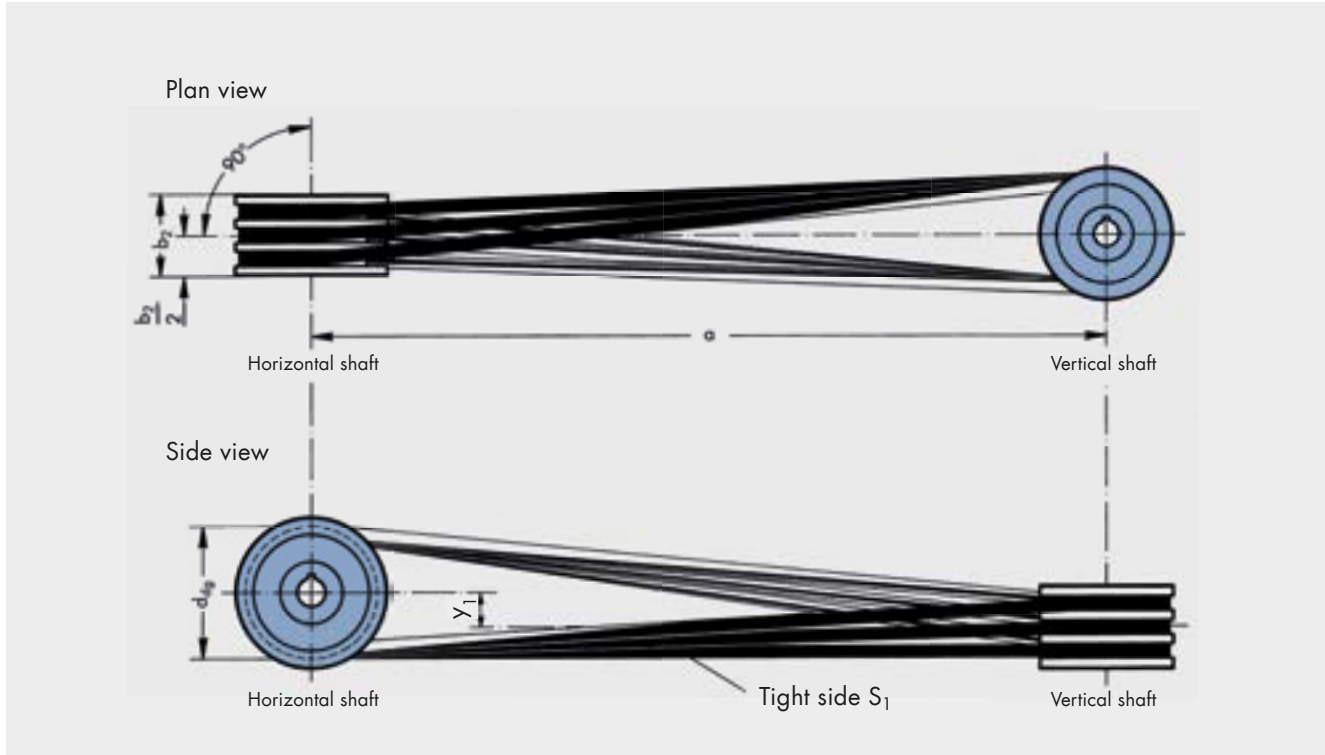

1. $a_{\min} = 5.5 (d_{dg} + b_2)$
2. The drive must be aligned in such a way that a straight line drawn through the centre of the vertical shaft runs through the centre of the face b_2 of the pulley on the horizontal shaft (plan view). The horizontal shaft must be at right angles to this straight line.
3. The horizontal centre line of the pulley on the horizontal shaft must be above and at a distance y_1 from the centre line of the pulley on the vertical shaft (side view). The distance y_1 changes with the centre distance "a".

Table 74

Drive centre distance a [mm]	y_1 [mm] Classic V-belts	y_1 [mm] Wedge belts
1200 ≤ 1500	5	–
> 1500 ≤ 2000	8	5
> 2000 ≤ 2500	12	8
> 2500 ≤ 3000	17	10
> 3000 ≤ 3500	25	15
> 3500 ≤ 4000	35	25
> 4000 ≤ 4500	45	30
> 4500 ≤ 5000	55	40
> 5000 ≤ 5500	65	45
> 5500 ≤ 6000	80	55
> 6000	100	65

4. The direction of rotation must be arranged so that the tight side S_1 is at the bottom.
5. Deep grooved pulleys should be specified if possible for single belt drives. This ensures an improved entry and exit of the belt, thus preventing turnover.
6. Never specify deep grooved pulleys when using kraftbands. Kraftband pulleys should always be used. We recommend, in any case, consulting our Application Engineering Department.
7. When calculating the number of belts, the examples given on pages 85 to 87 should be followed. An arc of contact correction factor $c_1 = 1$ must always be used.
8. The static belt tension "T" should be calculated using the formula on page 128.
9. The drive or work machine must be adjustable so that the belt can be fitted without force, the necessary tension can be applied and the belt stretch and wear can be taken up during its service life.

SPECIAL DRIVES

TWIST DRIVES

Eighth twist drives

Eighth twist drives are seldom necessary. The shafts in this drive system are at an angle of 45° to each other.

Design guidelines

- $a_{\min} = 4 (d_{dg} + b_2)$
- Otherwise the design guidelines for quarter twist drives are applicable.

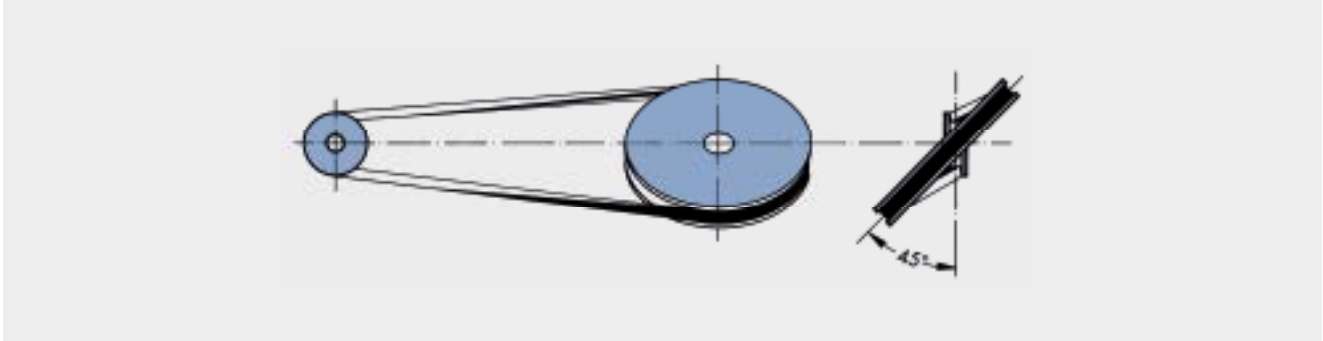

Drives with 180° twist

The driver and the driven shafts are, as with conventional drives, parallel to each other. The belt is twisted 180° so

that both spans cross. A change in direction is thus achieved at very little cost.

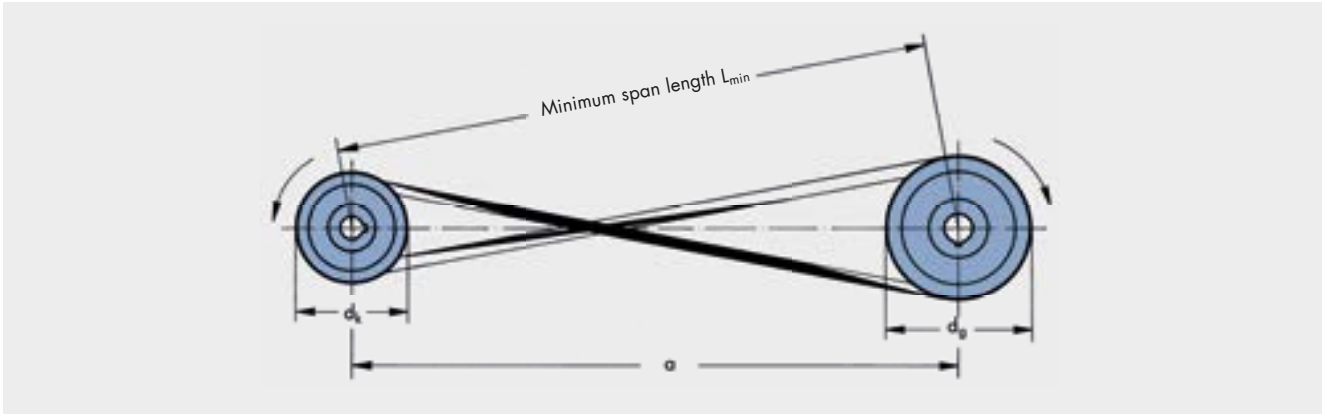

Design guidelines

- In order to enable a perfect running of the belts in the pulley grooves, the belt span length must not be less than the minimum given in the following table.
- If possible, the crossover point of both belt spans should be arranged in the centre of the drive. The rubbing of the belt spans against each other is at a minimum at this point. In order to avoid contact completely, it is recommended that a guide pulley is placed in the slack side S_2 near the crossover point.

Tabelle 75

Profile	Minimum span length L_{\min} [mm]
SPZ, 3V/9N	350
SPA	400
SPB, 5V/15N	450
SPC	600
8V/25N	700
A/13	460
B/17	560
C/22	720
D/32	940
E/40	1150

- Length calculation

$$L \approx 2a + 1.57 (d_g + d_k) + \frac{(d_g + d_k)^2}{4a}$$

- Otherwise, the design guidelines as described in points 4 to 9 for quarter twist drives apply.

◀ these values also apply for raw edge belts

SPECIAL DRIVES

DRIVE ELEMENTS WITH ARAMID STRUCTURES

Aramid is an organic polyamide fibre that is manufactured in a complex chemical process. It may be used wherever maximum stress resistance and reliability are required. The processing of this fibre requires the highest level of experience and know-how as well as sophisticated testing facilities. Aramid is used as the tension cord material for highly loaded V-belts and kraftbands.

Structure and properties

Compared to materials commonly used for tension cords e.g. polyesters, aramid stands out due to its extremely low-stretch properties. Its tensile strength is twice as high as that of a standard fibre in the same thickness.

	Tensile strength [cN/tex]	Stretching at break [%]	Tension at 2 % [cN/tex]
Polyester	81	14	15
Aramid	190	4	73

cN = Centi-Newton Thread weight: 1 tex = 1 g/1000 m

Despite its extreme strength, this fibre is remarkably flexible and has sufficient elasticity to absorb shock loads or vibration.

These properties, which are of special importance for V-belts and kraftbands, result in huge improvements in comparison to conventional constructions.

OPTIBELT V-belts in aramid cord structure comprise:

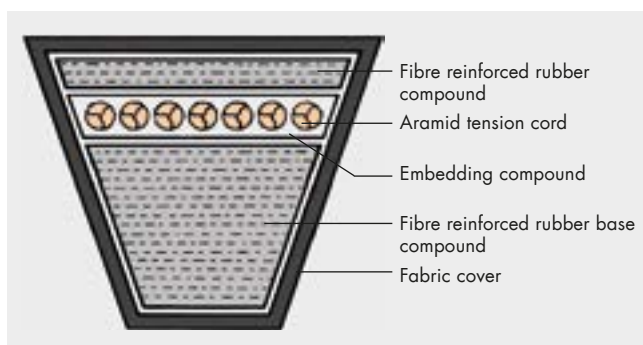

The high quality, specially processed aramid tension cord is embedded in a special rubber compound. The upper and substructure are thus supported effectively. These consist of a fibre reinforced polychloroprene rubber compound. The cover fabric is treated with a rubber compound on both sides and covers the whole belt.

Applications

The advantages of OPTIBELT V-belts and kraftbands with aramid tension cords are best applicable where

- high power transmission is required
- there is only small installation space
- there is little adjustment range
- high temperature influences occur

Thus, with the same number of belts and unchanged drive parameters, significantly higher power levels can be transmitted without reducing the service life of the belts. Even drive constructions that have previously had to be classified as critical may now be considered risk free. From now on, load limits apply as safety buffer zones; minimal belt stretch results in virtually maintenance-free running.

For these reasons OPTIBELT V-belts and kraftbands with aramid tension cord are to be found on drives with exceptional loading requirements –

- on critical drives in industrial applications
- on special machines
- on agricultural machinery
- on horticultural machinery

Attention: With two-pulley drives, particular requirements are placed on the shafts and bearings. It is recommended to use spring-loaded idlers (inside/outside idlers) with aramid V-belts / aramid kraftbands.

A discussion of all the relevant criteria would be beyond the scope of this manual. We therefore recommend contacting our Application Engineering Department to discuss your special requirements.

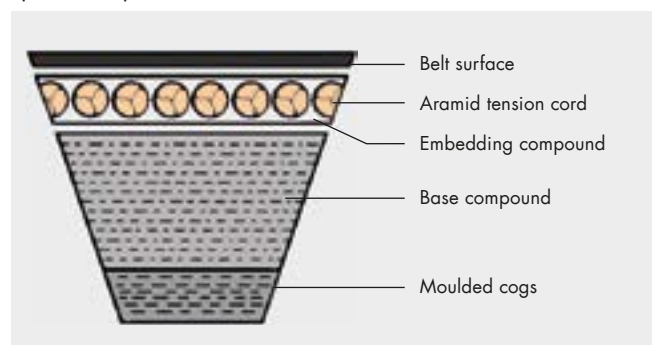

Special applications can also be designed with raw edge V-belts and kraftbands employing aramid tension cords.

Drive calculation

Calculation should follow the example given on pages 85 to 87.

Please ask for the higher power ratings.

SPECIAL DRIVES

DRIVE ELEMENTS WITH ARAMID STRUCTURES

Diagram 6

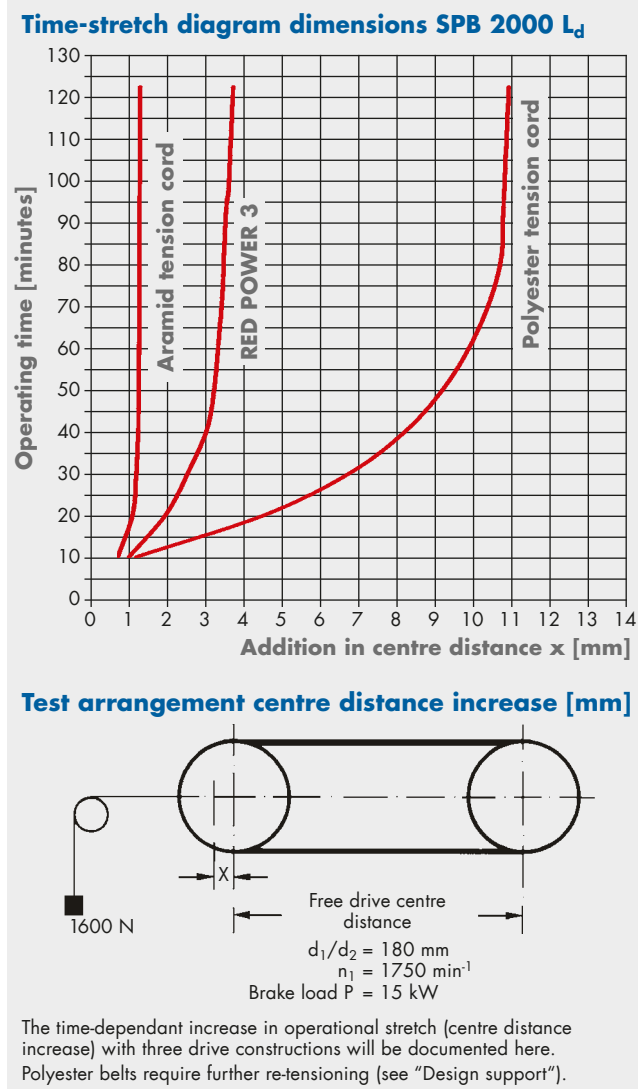
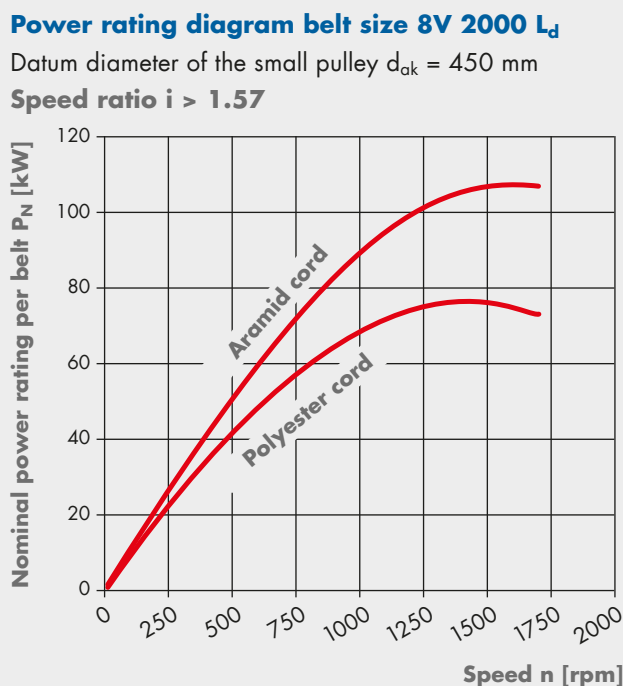

Diagram 7



This diagram shows the significantly higher power rating of the OPTIBELT V-belts with aramid cord in direct comparison to polyester cord belts.

Sections/Lengths

Raw edge and wrapped OPTIBELT V-belts and kraftbands are available with aramid to DIN/ISO and USA standard RMA/MPTA.

Lengths and minimum order quantities on request.

Special information:

Aramid belts are to be ordered in sets.

V-belts/kraftbands are to be ordered in sets.

Profile	Length		Range
V-belts			
SPZ	$\geq 1000 L_w$	$\leq 3550 L_w$	As per the OPTIBELT standard range
SPA	$\geq 1000 L_w$	$\leq 4500 L_w$	
SPB	$\geq 1250 L_w$	$\leq 8000 L_w$	
SPC	$\geq 2000 L_w$	$\leq 12500 L_w$	
3V/9N	$\geq 3V 400 / 9N 1016 L_a$	$\leq 3V 1400 / 9N 3556 L_a$	
5V/15N	$\geq 5V 500 / 15N 1270 L_a$	$\leq 5V 3550 / 15N 9017 L_a$	
8V/25N	$\geq 8V 1000 / 25N 2540 L_a$	$\leq 8V 5000 / 25N 12700 L_a$	
Kraftbands			
3V/9J	$\geq 3V 500 / 9J 1270 L_a$	$\leq 3V 1400 / 9J 3556 L_a$	
5V/15J	$\geq 5V 500 / 15J 1270 L_a$	$\leq 5V 3550 / 15J 9017 L_a$	
8V/25J	$\geq 8V 1000 / 25J 2540 L_a$	$\leq 8V 4750 / 25J 12065 L_a$	

Further profiles and length ranges as well as minimum order quantities on request.

Datum length $L_d \hat{=} \text{pitch length } L_w$; outside length = L_a

DESIGN SUPPORT

BELT TENSION FOR OPTIBELT V-BELTS

For proper power transmission and for achieving an acceptable belt service life, the correct belt tension is of the utmost importance.

Too low or too high belt tension will lead to the premature failure of the belts. Over tensioning often leads to bearing failure on the driver or the driven machine. Experience has shown that unscientific belt tensioning methods, such as the "thumb pressure method", are not suitable for applying the optimum tension to the drive for maximum efficiency. It is therefore recommended that for each drive the required static belt tension "T" is calculated using the formulas by OPTIBELT. This tension is the lowest possible required by a drive to transmit the highest power level from the drive, taking account of the normal amount of slip.

Once the belt has been fitted and the initial tension has been applied, it should be checked using a OPTIBELT tension gauge.

The belt should be monitored regularly during the first hours of operation. Experience has shown that the first re-tensioning should be carried out after approximately 30 minutes to four hours operating under full load. In doing so, the initial stretch is absorbed.

After approximately 24 hours of operation, it is often recommended to check the drive and re-tension the belts if necessary, particularly when not continuously run under full load. The time between checks can be significantly increased then. Also see our installation and maintenance advice on pages 150 to 151.

Too high or too low tension of the drive will be avoided if the belt tension is calculated, set and checked using one of the following methods.

I. Checking the belt tension by span deflection

This method provides an indirect measurement of the calculated or actual static belt tension. It is applicable for belt sections SPZ, SPA, SPB, SPC, 3V/9N, 5V/15N, Z/10, A/13, B/17, 20, C/22, 25, D/32, XPZ, XPA, XPB, XPC, 3VX, 5VX, ZX/X10, AX/X13, BX/X17, CX/X22.

E	= belt deflection per 100 mm span length	[mm]
E _a	= belt deflection for a given span length	[mm]
f	= load used to set belt tension	[N]
k	= constant for calculation of centrifugal force	
L	= drive span length	[mm]
S _a	= minimum static shaft load	[N]
T	= minimum static tension per belt	[N]

1. Calculation of the static belt tension using the following formula:

$$T \approx \frac{500 \cdot (2.02 - c_1) \cdot P_B}{c_1 \cdot z \cdot v} + k \cdot v^2$$

During new installation, the drive is to be tensioned with 1.3 T.

2. Determine the belt deflection per 100 mm span length E from the belt tension/deflection diagrams 8 to 11.

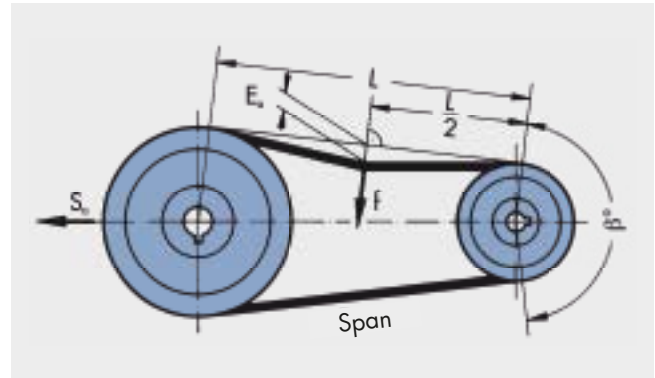

3. Calculate the belt deflection for a given span length E_a for the actual drive span length L.

$$E_a \approx \frac{E \cdot L}{100}$$

$$L = a_{nom} \cdot \sin \frac{\beta}{2}$$

Apply test load "f" (taken from diagrams 8 to 11 for the appropriate belt profile) to the centre of, and perpendicular to, the span as illustrated above. Measure the deflection and if necessary adjust the centres until the correct belt tension is achieved.

II. Checking the belt tension via speed measurement

This method checks belt tension using the theoretical slip. The speed of the driver and driven pulleys are measured first in an unloaded condition and then under load.

S	= slip	[%]
n _{1L}	= driver pulley speed, no load	[rpm]
n _{2L}	= driven pulley speed, no load	[rpm]
n _{1B}	= driver pulley speed, under load	[rpm]
n _{2B}	= driven pulley speed, under load	[rpm]

Formula for calculating the slip:

$$S = \left(1 - \frac{n_{1L}/n_{2L}}{n_{1B}/n_{2B}}\right) \cdot 100$$

At the rated loading, the slip should not exceed 1%. The belt service life is considerably shortened due to incorrectly low tension or overloading with a slip of over 2%.

DESIGN SUPPORT

BELT TENSION FOR OPTIBELT V-BELTS

Diagram 8: Belt tension characteristics for optibelt SK high performance wedge belts DIN 7753 Part 1

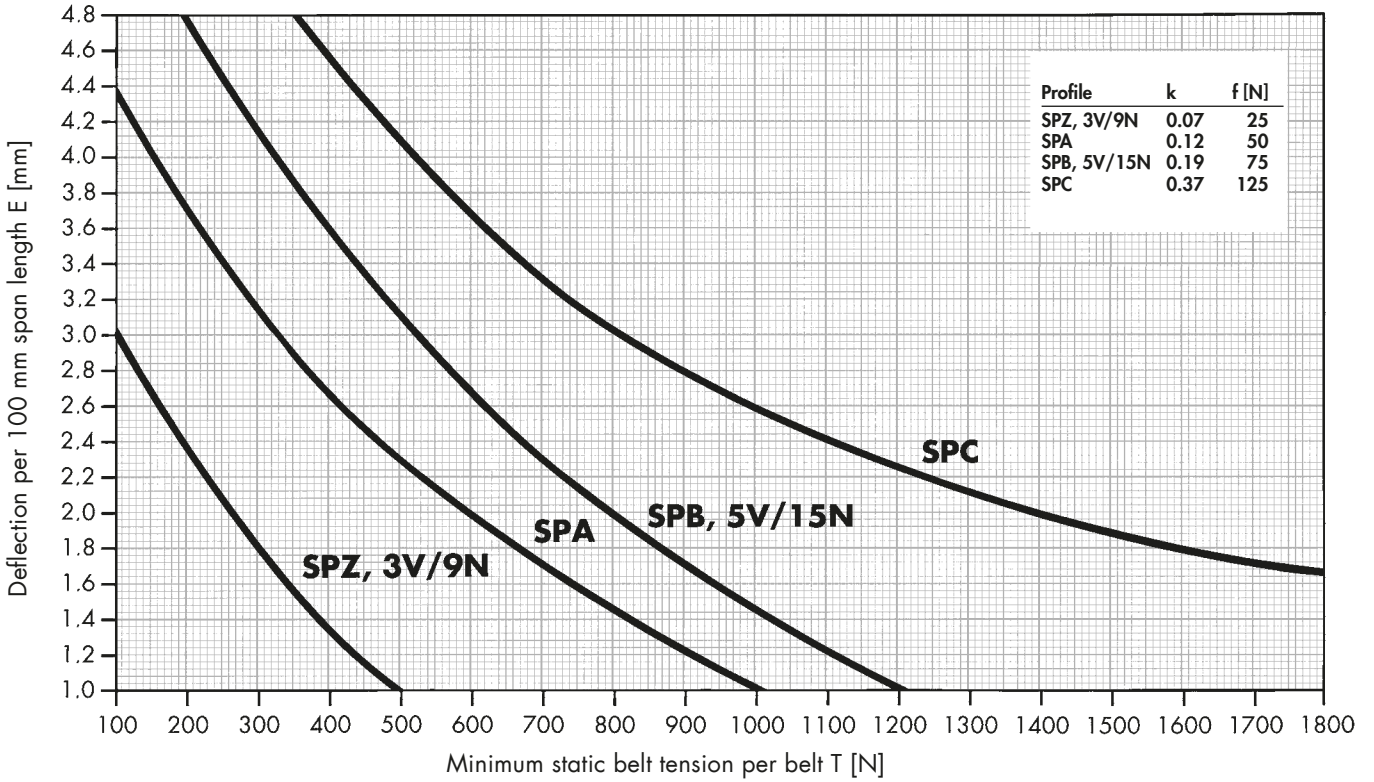
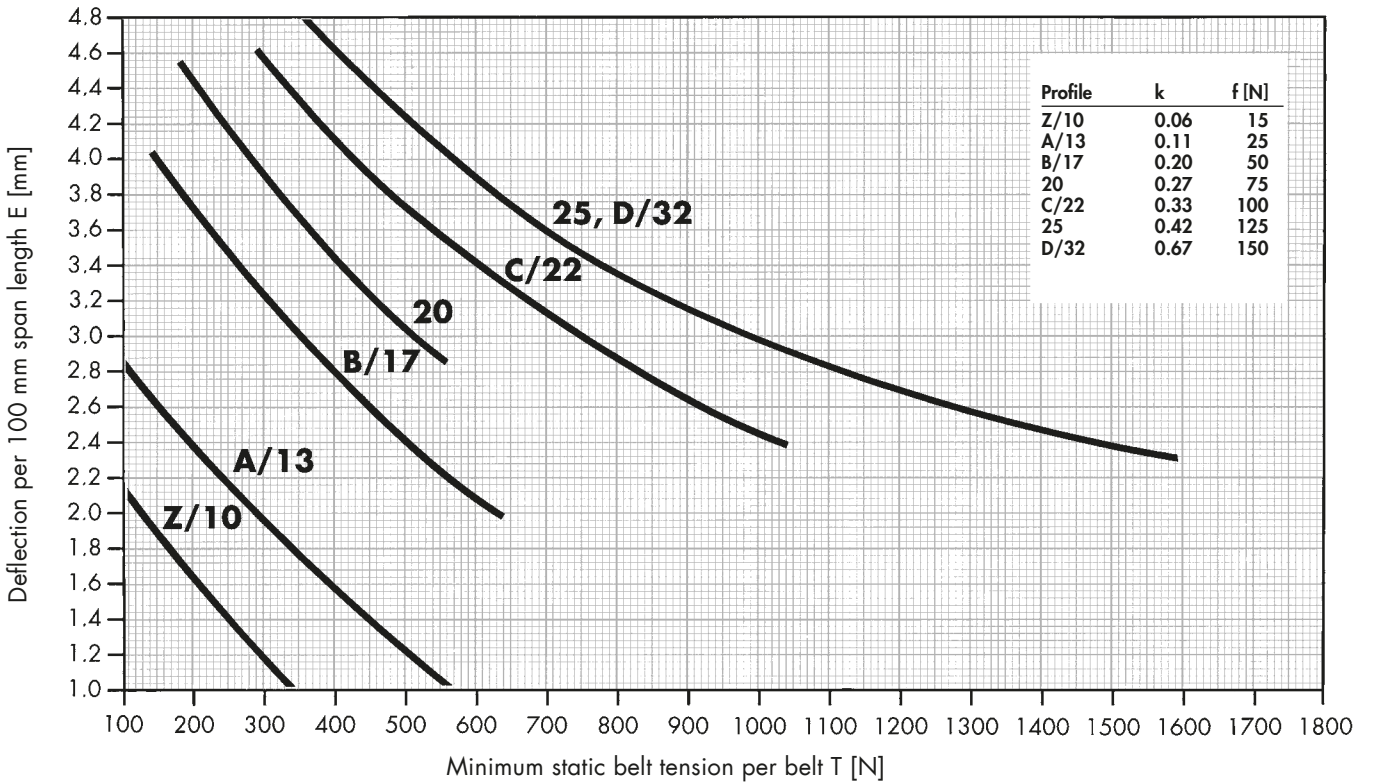

Diagram 9: Belt tension characteristics for optibelt VB classic V-belts DIN 2215



DESIGN SUPPORT

BELT TENSION FOR OPTIBELT V-BELTS

Diagram 10: Belt tension characteristics for optibelt X-POWER M=S wedge belts – raw edged, moulded cogged

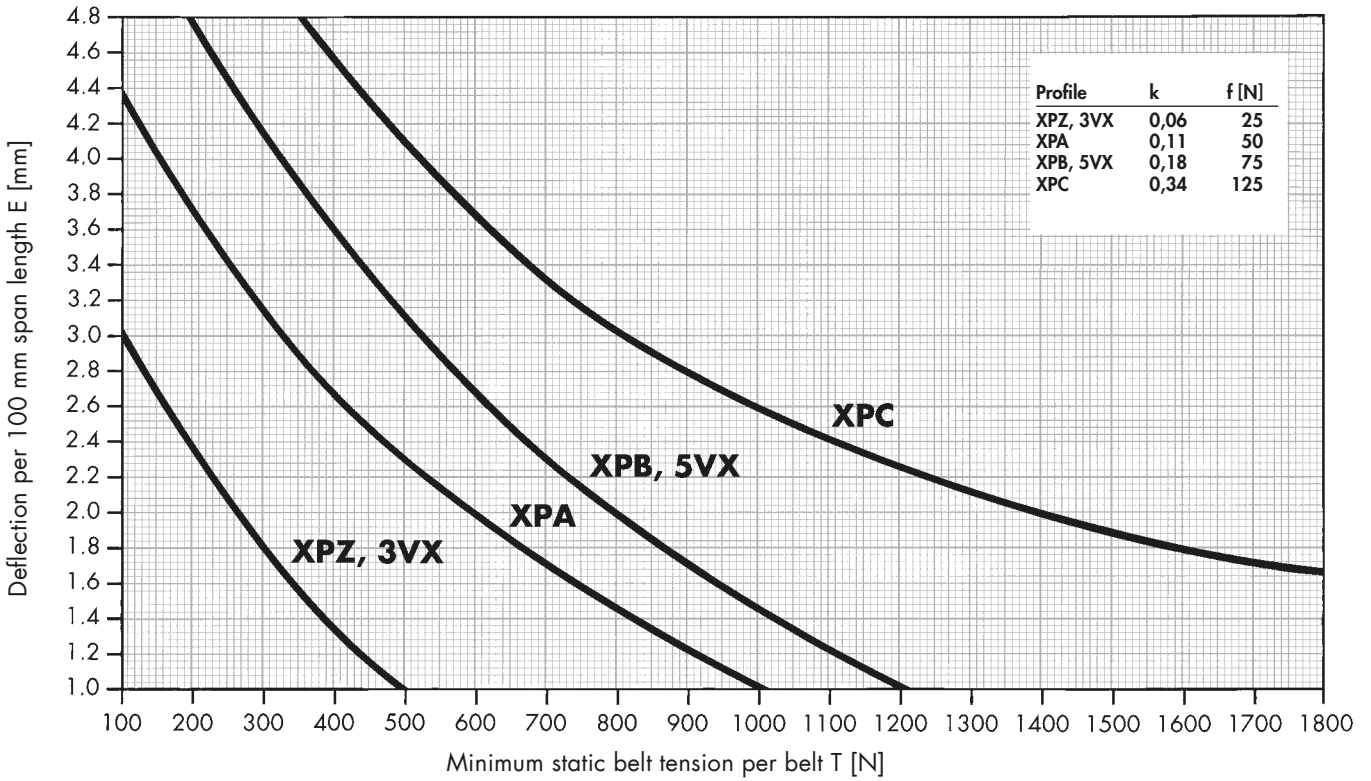
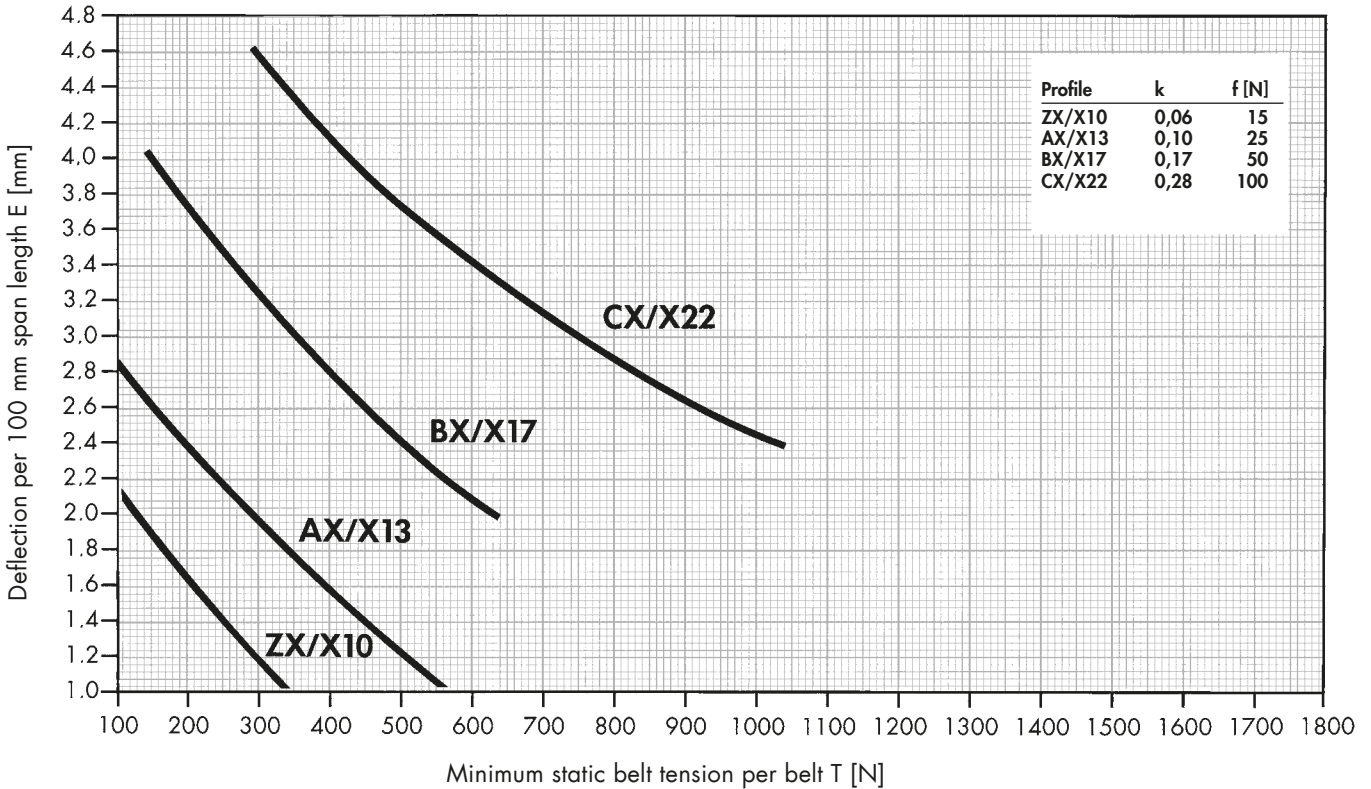

Diagram 11: Belt tension characteristics for optibelt SUPER TX M=S V-belts DIN 2215



DESIGN SUPPORT

BELT TENSION FOR OPTIBELT V-BELTS AND optibelt **KB** KRAFTBANDS

III. Belt tensioning via "length addition value" method

It has become evident that span deflection methods are not ideal for checking the tension of kraftbands of all profiles, and of individual belts. The following, very simple method for the setting and checking of belt tension is therefore recommended:

1. Calculation of the static belt tension "T":

$$T \approx \frac{500 \cdot (2.02 - c_1) \cdot P_B}{c_1 \cdot z \cdot v} + k \cdot v^2$$

2. Measure the setting length "M" of the kraftband or the single belt, on the top surface of the kraftband or on the belt top surface when not tensioned. However the belt can be measured when fitted to the drive, provided that it is completely **without** tension.

3. Procedure

- a) Install the kraftband or the single belt on the pulleys. Provisionally tighten the belt in order to seat it into the pulley grooves.
- b) Next, completely slacken the kraftband or the single belt.
- c) Mark two lines on the top of the belt, with distance "M". The lines must be marked on the free span length, not where the belt is on the pulley, ("M" should ideally be 1000 mm minimum or a multiple of it).

Important: The longer the measured profile, the more accurate the tension setting will be.

4. Calculate the length additional value "A" using the formula:

$$A = \frac{M \cdot R}{1000}$$

R = Dehnungsfaktor aus Tabelle 76, Seite 141

5. Tighten the kraftband or the single belt until the length calculated under point 4 is reached. The drive is now correctly tensioned.
6. If the drive has to be re-tensioned, the belts have to be slackened first so that they can be re-measured completely free of tension. After that, the procedure described in paragraphs 3 to 5 applies.

Example:

$$P_B = 1136 \text{ kW}$$

$$c_1 = 0.97$$

$$v = 25.91 \text{ m/s}$$

Drive arrangement with one set comprising:

2 optibelt KB kraftbands 4-8V 3750/25J 9525 L₀

2 optibelt KB kraftbands 5-8V 3750/25J 9525 L₀

$$T \approx \frac{500 \cdot (2.02 - 0.97) \cdot 1136}{0.97 \cdot 18 \cdot 25.91} + 0.69 \cdot 25.91^2 = 1782 \text{ N}$$

„M“ selected 4000 mm

$$A = \frac{4000 \cdot 5.4}{1000} = 21.6 \text{ mm}$$

Tighten the kraftband until the length additional value is reached. This will set the correct tension.

At initial installation, the static belt tension must be multiplied by 1.3.

DESIGN SUPPORT

BELT TENSION FOR OPTIBELT V-BELTS AND optibelt **KB** KRAFTBANDS

Table 76: Length addition per 1000 mm belt length

Profile	Kraftband	3V/9J	5V/15J	8V/25J	SPZ	SPA	SPB	SPC	A/HA	B/HB	C/HC	D/HD
	Single belt	3V/9N	5V/15N	8V/25N	SPZ	SPA	SPB	SPC	A/13	B/17	C/22	D/32
		[mm]	[mm]	[mm]	[mm]	[mm]	[mm]	[mm]	[mm]	[mm]	[mm]	[mm]
Minimum static belt tension per rib/single belt T [N]	50	0.8			0.8	0.8			0.8			
	75	1.2			1.2	1.0			1.0			
	100	1.6			1.6	1.3			1.3			
	125	2.1			2.1	1.6			1.6			
	150	2.6			2.6	1.9			1.9	0.8		
	175	3.0			3.0	2.2			2.2	0.9		
	200	3.5			3.5	2.5			2.5	1.1		
	225	4.0			4.0	2.8			2.8	1.2		
	250	4.5			4.5	3.0			3.0	1.4		
	275	4.9			4.9	3.3			3.3	1.5		
	300	5.3	1.3		5.3	3.6	1.3		3.6	1.6	1.6	
	350	6.4	1.7		6.4	4.2	1.7		4.2	1.8	1.8	
	400	7.6	2.0		7.6	4.7	2.0		4.7	2.0	2.1	
	450	8.7	2.4		8.7	5.3	2.4		5.3	2.2	2.3	
	500	10.0	2.7		10.0	5.8	2.7		5.8	2.5	2.5	
	550		3.1				3.1			2.7	2.7	
	600		3.4				3.4	2.0		3.0	2.9	2.0
	650		3.8				3.8	2.2		3.2	3.1	2.2
	700		4.1				4.1	2.4		3.5	3.4	2.4
	800		4.8				4.8	2.8		4.2	3.8	2.7
	900		5.5				5.5	3.3		4.8	4.2	2.9
	1000		6.2				6.2	3.7		5.3	4.7	3.3
	1100		6.9				6.9	4.1			5.1	3.6
	1200		7.6	2.9			7.6	4.5			5.5	3.9
	1300		8.3	3.3			8.3	5.0				4.2
	1400		9.0	3.7			9.0	5.4				4.5
	1500		9.7	4.1			9.7	5.8				4.8
	1600		10.4	4.6			10.4	6.3				5.1
	1700		11.1	5.0			11.1	6.8				5.5
	1800		11.8	5.5			11.8	7.3				5.8
	1900			6.0				7.8				
	2000			6.5				8.3				
	2100			7.0				8.8				
2200			7.5				9.3					
2300			8.0				9.8					
2400			8.6									
2500			9.6									
2600			10.6									
2700			11.7									
2800			12.8									
2900			13.5									
3000			14.2									
3100			14.9									
3200			15.6									
3300			16.3									
Factor k for kraftbands	0.12	0.25	0.69	0.12	0.16	0.25	0.55	0.16	0.27	0.45	0.85	
Factor k for single belts	0.07	0.19	0.57	0.07	0.12	0.19	0.37	0.11	0.20	0.33	0.67	

Intermediate values may be determined by linear interpolation.
 The values only apply to drives with V-grooved pulleys.
 Values for V-flat drives on request.

DESIGN SUPPORT

CALCULATING THE AXIAL LOAD/SHAFT LOAD UNDER DYNAMIC CONDITIONS

Using drives that have electric motors as drive machines and are/or will be designed according to DIN 2211 Part 3, ensures that the dynamic stress that occurs can be absorbed by the appropriate shafts and bearings of the motor.

As often occurs, drives with

- electric motors out with the DIN standards for the determined dependencies of pulley diameter and power,
- combustion engines,
- turbines as well as,
- heavy duty drives such as stone crushers, calenders or heavily loaded mills

than the dynamic bearing load must be calculated. This is the load on both shaft and bearing on the driver and driven unit.

Precise calculation of the "Dynamic axial load" prevents unnecessary costs due to

- premature failure of the bearing,
- breaking of the shaft,
- over dimensioned bearings and shafts.

In the case of 2-pulley drives, the driver and driven shafts and the bearings are subjected to the same dynamic axial force, but in opposite directions. When idlers are employed, the magnitude and the direction of the axial force are almost always different on each pulley. If the magnitude and direction of the dynamic axial force is to be determined, a graphical solution, using a vector diagram for the dynamic forces in the tight side S_1 and the slack side S_2 , is recommended.

If only the magnitude of the dynamic axial force has to be determined, this can be achieved using the formula for " $S_{a \text{ dyn}}$ ". Both procedures will be illustrated in the following example. Data from the calculation examples given on pages 85 to 87

$P_B = 171.6 \text{ kW}$
 $v = 21.76 \text{ m/s}$

$c_1 = 1.00$
 $\beta = 170^\circ$

Dynamic tension on the tight side during belt operation

$$S_1 \approx \frac{1020 \cdot P_B}{c_1 \cdot v}$$

$$S_1 \approx \frac{1020 \cdot 171.6}{1.0 \cdot 21.76} \approx \mathbf{8044 \text{ N}}$$

Dynamic tension of the slack side during belt operation

$$S_2 \approx \frac{1000 \cdot (1.02 - c_1) \cdot P_B}{c_1 \cdot v}$$

$$S_2 \approx \frac{1000 \cdot (1.02 - 1.0) \cdot 171.6}{1.0 \cdot 21.76} \approx \mathbf{158 \text{ N}}$$

A) Graphical solution

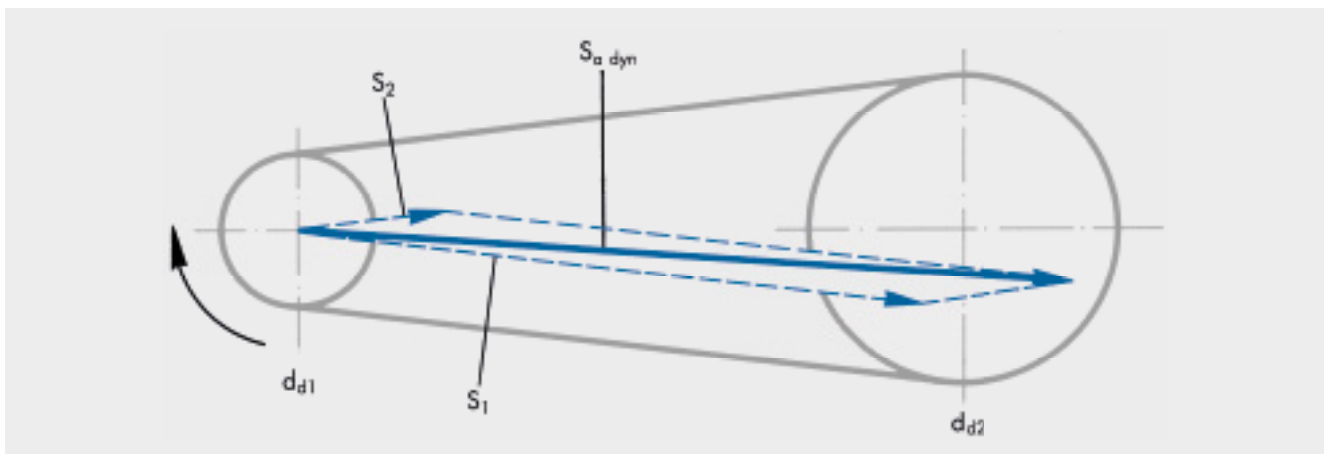

B) Solution using the formula $S_{a \text{ dyn}}$

Axial load under dynamic conditions

$$S_{a \text{ dyn}} \approx \sqrt{S_1^2 + S_2^2 - 2 \cdot S_1 \cdot S_2 \cdot \cos \beta}$$

$$S_{a \text{ dyn}} \approx \sqrt{8044^2 + 158^2 - 2 \cdot 8044 \cdot 158 \cdot 0.9848} \approx \mathbf{8200 \text{ N}}$$

DESIGN SUPPORT

TECHNICAL TOOLS

FREQUENCY TENSION TESTER **optibelt TT MINI S**

The optibelt TT MINI S frequency tension tester is used for checking the tension of drive belts via frequency measurement.

This newly designed measuring device offers universal application options for drives in machine construction, the automotive industry and various other applications due to its compact design.

Even difficult to reach spots can be tackled with the TT MINI S.

The tension values of V-belts, ribbed belts and timing belts can easily and quickly be checked.

Furthermore, the TT MINI S offers:

- value display in Hertz [Hz]
- large measuring range from 10 to 600 Hz
- simple and repeatable measuring
- small, compact design (mobile phone size)
- automatic switch off
- factory calibration and CE approval

After switching on the device, it is ready for immediate measurement. The mounted and tensioned belt is made to vibrate by finger pressure or by hitting it with something. The measuring head has to be held above the belt to function, the TT MINI S starts the measurement and displays the result in Hertz [Hz]. The state, colour and type of the belt do not influence the measurement, since the measurement is based on an acoustic signal.

Belt tension calculation

Formula: $T = 4 \cdot k \cdot L^2 \cdot f^2$

$T \triangleq$ belt tension [N]
 $k \triangleq$ meter weight [kg/m]
 $L \triangleq$ belt length [m]
 $f \triangleq$ frequency [Hz]



TECHNICAL DATA

Display:

LCD, two-line display

Measuring range:

10 to 600 Hz

Measuring accuracy:

10-400 Hz +/- 1 %
> 400 Hz +/- 2 %

Solution:

10-99.9 Hz 0.1 Hz
> 100 Hz 1 Hz

Sensor:

acoustic, with electronic background noise reduction

Power supply:

batteries, 2 x Micro (AAA cells)

Power consumption:

max. 12 mA

Operating time:

> 48 hours non-stop operation
(depending on the battery quality),
automatic switch off after 5 minutes

Dimensions:

110 mm x 50 mm x 25 mm

Weight:

≤ 100 g

Tested:

CE approval
Factory calibration

Accessories:

batteries, bag

DESIGN SUPPORT

TECHNICAL TOOLS

FREQUENCY TENSION TESTER optibelt TT OPTICAL

The optibelt TT OPTICAL frequency tension tester is used for checking the tension of drive belts via frequency measurement.

This newly designed measuring device offers universal application options for drives in machine construction, the automotive industry and various other applications due to its compact design.

The tension values of V-belts, ribbed belts and timing belts can easily and quickly be checked.

Furthermore, the TT OPTICAL offers the following advantages:

- easy handling
- measuring range 5 Hz to 500 Hz
- compact design
- highest reliability
- high measuring accuracy
- no influence due to background noise
- factory calibrated
- CE approved

After switching on, the device is instantly ready for measuring. The pre-tensioned belt is set into vibration by impulse with finger or any other object. The measuring detector has to be placed over the belt. TT OPTICAL starts measuring and the result is displayed in Hertz [Hz].

The structure, colour and type of drive belt has no influence on the measurement, as an optical measuring method is used.



TECHNICAL DATA

Display:

LCD, two-line display

Measuring range:

50 to 500 Hz

Measuring accuracy:

< 10 Hz = 0.5 Hz

> 10 Hz = 1.0 Hz

Sensor:

optical, with sensor

Power supply:

9 V block battery

Operating time/Switch off automatic:

> 48 hours non-stop operation
(depending on the battery quality),
automatic switch off after 2 minutes

Dimensions:

170 mm x 45 mm x 30 mm

Weight:

≤ 100 g

Tested:

CE approval, RoHS,
factory calibration

Accessories:

battery

DESIGN SUPPORT

TECHNICAL TOOLS

optibelt OPTIKRIK TENSION GAUGES

This gauge offers a simple method of belt tensioning.

It helps e. g. mechanics during the maintenance of belt drives when technical data is not known and the optimum tension therefore cannot be calculated. This method requires only knowledge of the diameter of the small pulley and the belt profile. The OPTIBELT tension gauge is used to directly read the belt tension. By reducing or increasing the belt tension the desired value is achieved.

For different tensioning values, OPTIKRIK 0, I, II, III with corresponding measurement ranges are available.

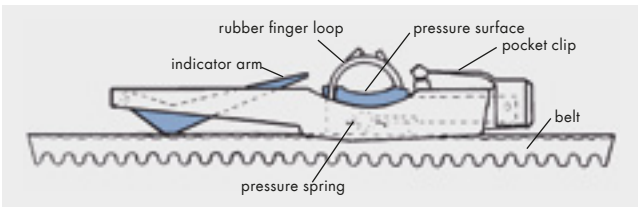

Instructions for use

1. The gauge is placed in the middle between the two pulleys on the back of the belt, in the case of sets of belts ideally on the belt in the middle. (Before doing so, please press the indicator completely into the gauge body.)
2. Place the gauge loosely on the belt to be measured and slowly press a finger onto the pressure surface.
3. Try not to touch the gauge with more than one finger during the measuring process.
4. When you feel or hear a definite "click", immediately release the pressure, the indicator arm stays in the measured position.
5. Carefully lift the gauge without moving the indicator arm. Read the belt tension (see diagram). Read the measurement at the exact point where the top of the indicator arm crosses the scale.
6. Reduce or increase the belt tension according to the measurement result until it is within the desired tension level.

DESIGN SUPPORT

BELT TENSION FOR WRAPPED OPTIBELT V-BELTS

Profile	Diameter of the small pulley [mm]	Static belt tension [N]						
		RED POWER 3		Standard (wrapped)		BLUE POWER		
		Initial installation new V-belts	Initial installation existing V-belts	Initial installation	Operation after running in	Diameter of the small pulley	Initial installation new V-belts	Operation after running in
SPZ; 3V/9N	≤ 71	250	200	200	150	—	—	—
	> 71 ≤ 90	300	250	250	200	—	—	—
	> 90 ≤ 125	400	300	350	250	—	—	—
	> 125*					—	—	—
SPA	≤ 100	400	300	350	250	—	—	—
	> 100 ≤ 140	500	400	400	300	—	—	—
	> 140 ≤ 200	600	450	500	400	—	—	—
	> 200*					—	—	—
SPB; 5V/15N	≤ 160	700	550	650	500	≤ 180	780	600
	> 160 ≤ 224	850	650	700	550	> 180 ≤ 236	1100	850
	> 224 ≤ 355	1000	800	900	700	> 236 ≤ 400	1500	1100
	> 355*					> 400*		
SPC	≤ 355	1400	1100	1000	800	≤ 280	1600	1200
	> 355 ≤ 560	1600	1200	1400	1100	> 280 ≤ 375	2500	1900
	> 560*	1900	1500	1800	1400	> 375 ≤ 700	3100	2400
						> 700*		
Z/10	> 50 ≤ 71	—	—	120	90	—	—	—
	> 71 ≤ 100	—	—	140	110	—	—	—
	> 100*					—	—	—
A/13	≤ 80	—	—	150	110	—	—	—
	> 80 ≤ 100	—	—	200	150	—	—	—
	> 100 ≤ 132	—	—	300	250	—	—	—
	> 132*					—	—	—
B/17	≤ 125	—	—	300	250	—	—	—
	> 125 ≤ 160	—	—	400	300	—	—	—
	> 160 ≤ 200	—	—	500	400	—	—	—
	> 200*					—	—	—
C/22	≤ 200	—	—	700	500	—	—	—
	> 200 ≤ 250	—	—	800	600	—	—	—
	> 250 ≤ 355	—	—	900	700	—	—	—
	> 355*					—	—	—
D/32	≤ 355	—	—	1000	750	—	—	—
	> 355*			1200	900	—	—	—

8V

Check of belt tension via length addition value

* Tension values for these pulleys must be calculated.

Tension gauges:

OPTIKRIK 0	Measuring range: 70 - 150 N
OPTIKRIK I	Measuring range: 150 - 600 N
OPTIKRIK II	Measuring range: 500 - 1400 N
OPTIKRIK III	Measuring range: 1300 - 3100 N

The tension values (static belt tension) are reference values, if no exact drive data is available. These values are given for maximum power transmission (per belt).

Calculation basis

Wedge belts	speed $v = 5$ to 42 m/s
Classic V-belts	speed $v = 5$ to 30 m/s

DESIGN SUPPORT

BELT TENSION FOR RAW EDGE OPTIBELT V-BELTS

Profile	Diameter of the small pulley [mm]	Static belt tension [N]	
		SUPER X-POWER M=S SUPER E-POWER M=S SUPER TX M=S	
		Initial installation	Operation after running in
XPZ; 3VX/9NX	≤ 71	250	200
	> 71 ≤ 90	300	250
	> 90 ≤ 125	400	300
	> 125*		
XPA	≤ 100	400	300
	> 100 ≤ 140	500	400
	> 140 ≤ 200	600	450
	> 200*		
XPB; 5VX/15NX	≤ 160	700	550
	> 160 ≤ 224	850	650
	> 224 ≤ 355	1000	800
	> 355*		
XPC	≤ 250	1400	1100
	> 250 ≤ 355	1600	1200
	> 355 ≤ 560	1900	1500
	> 560*		
ZX/X10	≤ 50	120	90
	> 50 ≤ 71	140	110
	> 71 ≤ 100	160	130
	> 100*		
AX/X13	≤ 80	200	150
	> 80 ≤ 100	250	200
	> 100 ≤ 132	400	300
	> 132*		
BX/X17	≤ 125	450	350
	> 125 ≤ 160	500	400
	> 160 ≤ 200	600	450
	> 200*		
CX/X22	≤ 200	800	600
	> 200 ≤ 250	900	700
	> 250 ≤ 355	1000	800
	> 355*		
DX/X32	≤ 355	1000	750
	> 355*	1200	900

* Tension values for these pulleys must be calculated.

Tension gauges:

OPTIKRIK 0	Measuring range: 70 - 150 N
OPTIKRIK I	Measuring range: 150 - 600 N
OPTIKRIK II	Measuring range: 500 - 1400 N
OPTIKRIK III	Measuring range: 1300 - 3100 N

The tension values (static belt tension) are reference values, if no exact drive data is available. These values are given for maximum power transmission (per belt).

Calculation basis

Wedge belts	speed $v = 5$ bis 42 m/s
Classic V-belts	speed $v = 5$ bis 30 m/s

DESIGN SUPPORT

INSTALLATION AND MAINTENANCE SUPPORT

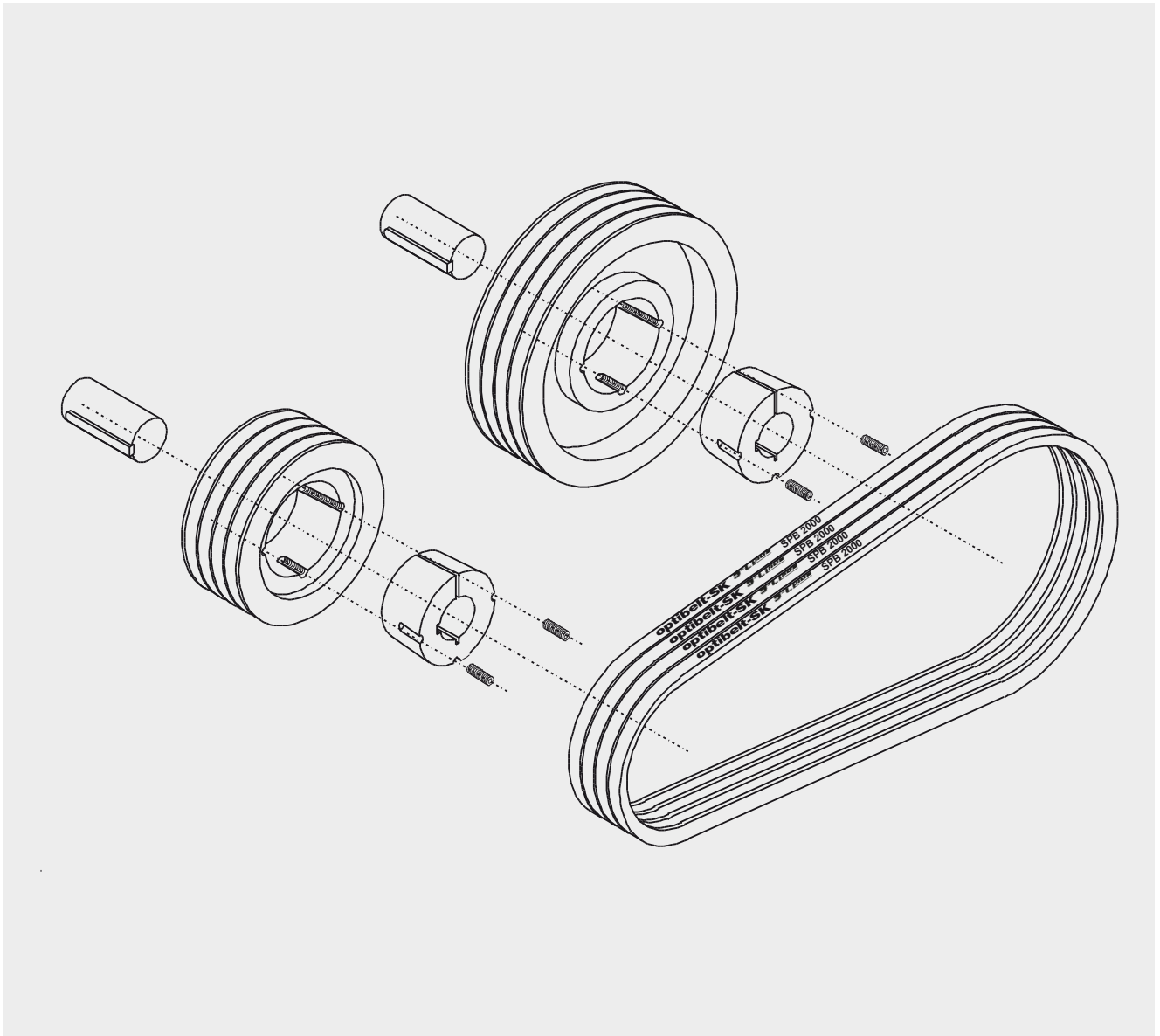

DESIGN SUPPORT

INSTALLATION AND MAINTENANCE SUPPORT

Safety: Before starting any maintenance work, it is extremely important that any machine components are in a safe position which cannot be changed during maintenance work. In addition, safety recommendations of the manufacturer are to be strictly observed.

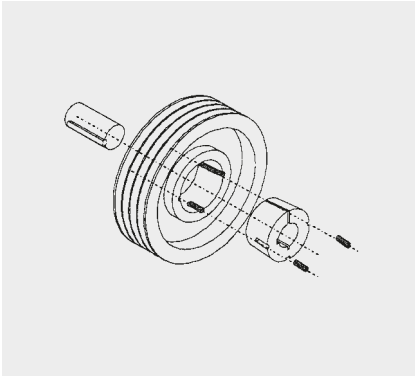

optibelt KS V-GROOVED PULLEY WITH TAPER BUSH

The V-grooved pulleys are to be checked for damage and correct dimensions before installation.

Installation

1. All shiny surfaces like bore and tapered surface of the pulley have to be cleaned and degreased. Insert taper bush in hub and align all connecting bores. Half tapped holes have to face half plain bores.
2. Stud screws (TB 1008-3030) and/or cap head screws (TB 3525-5050) should be slightly greased and screwed in. Do not yet tighten the screws.
3. Clean and degrease the shaft. Push pulley with taper bush to the desired position on the shaft. See alignment of the V-grooved pulley.
4. When using a key, it has to be inserted in the hub of the shaft first. Between key and bore hub there needs to be a certain tolerance.
5. With a socket wrench according to DIN 911 stud screws and/or cap head screws have to be tightened equally using the tightening torque stated in the table.
6. After a short operating time (0.5 to 1 hour) check tightening torque of the screws and correct if necessary.
7. In order to prevent the entering of foreign substances, fill empty connection bores with grease.

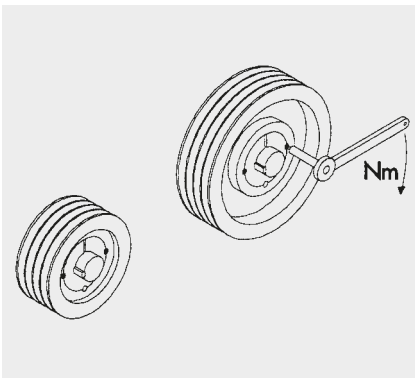

TAPER BUSHES, SCREW TIGHTENING TORQUE

Dimension	Wrench size	Number of screws	Tightening torque [Nm]
TB 1008, 1108	3	2	5.7
TB 1210, 1215, 1310, 1610, 1615	5	2	20.0
TB 2012	6	2	31.0
TB 2517	6	2	49.0
TB 3020, 3030	8	2	92.0
TB 3525, 3535	10	3	115.0
TB 4040	12	3	172.0
TB 4545	14	3	195.0
TB 5050	14	3	275.0

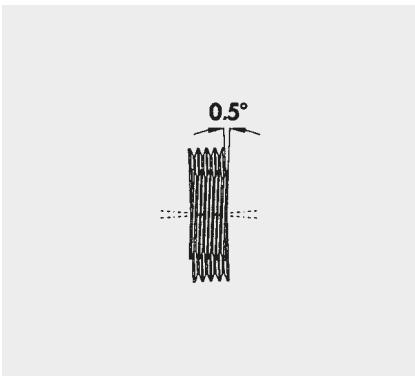

HORIZONTAL ALIGNMENT OF SHAFTS

Motor and drive shafts are to be aligned using a spirit level, if necessary.

Note!

Maximum shaft deviation 0.5°

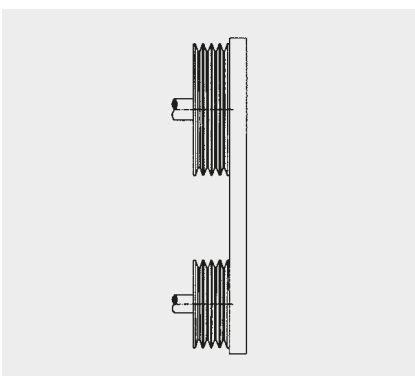

VERTICAL ALIGNMENT OF THE V-GROOVED PULLEYS

The alignment of the V-grooved pulleys is checked before and after tightening the taper bushes with an alignment rail.

Note

Check whether the face widths of the V-grooved pulleys have the same sizes. A possible deviation of the face width has to be taken into account. With a symmetrical face set-up, the distance of the parallel, to the smaller face is half the deviation.

DESIGN SUPPORT

INSTALLATION AND MAINTENANCE SUPPORT

INITIAL INSTALLATION

Always install the V-belts without force. Installations using screw drivers, crowbars etc. cause external and internal damage to the belt. V-belts installed under force might only run for several days. A proper installation of the belt saves time and money.

If the installation space is too small, the V-grooved pulleys with belts should be slid onto the shafts.

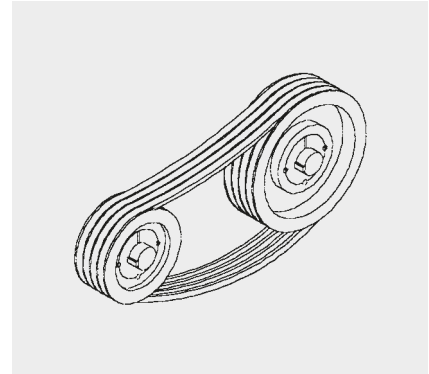

BELT TENSION

Use belt tensioning values according to OPTIBELT recommendations. Set the belt tension with parallel motor and machine shafts. Operate the belt for some rotations and check the belt tension again. In our experience, belt tension should be checked again after an operating time of about 0.5 to 4 hours and then be corrected, if necessary.

For further information about belt tensioning see page 143/144.

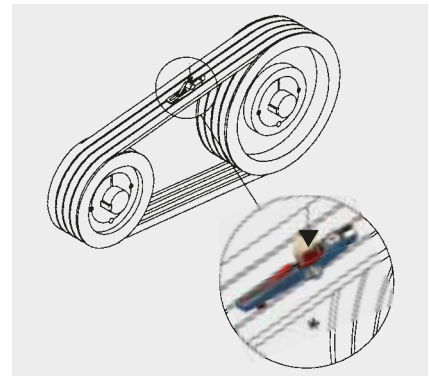

* OPTIKRIK

ALLOWED SHAFT DEVIATION

After applying the initial installation tension, the distances X_1 , X_2 between the two pulleys d_{d1} , d_{d2} and the alignment rail on axis level should be measured, alternatively with the optibelt LASER POINTER. The maximum allowed values for the distance X from the table should not be exceeded, depending on the diameter d_d . Depending on the pulley diameter, the intermediate values for X should be interpolated.

Pulley diameter d_{d1} , d_{d2}	Maximum allowed deviation X_1 , X_2
112 mm	0.5 mm
224 mm	1.0 mm
450 mm	2.0 mm
630 mm	3.0 mm
900 mm	4.0 mm
1100 mm	5.0 mm
1400 mm	6.0 mm
1600 mm	7.0 mm

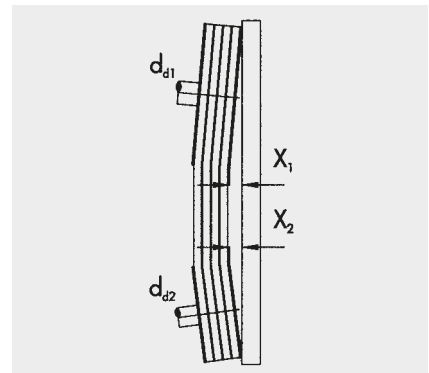

DRIVE CHECKING

We recommend checking the drive regularly, e.g. after each 3 to 6 months. V-grooved pulleys are to be checked for wear and consistency. Use the OPTIBELT profile and V-groove gauge tools.

When changing V-grooved pulleys with taper bushes (see fig. on page 152) the following aspects have to be observed:

1. Loosen all screws. Unscrew out one or two screws depending on the bush size, grease them and screw them into the set bores.
2. Tighten the screw or screws equally until the bush releases from the hub and the pulley can be moved freely on the shaft.
3. Remove the pulley with the bush from the shaft.

** Profile and V-groove gauge

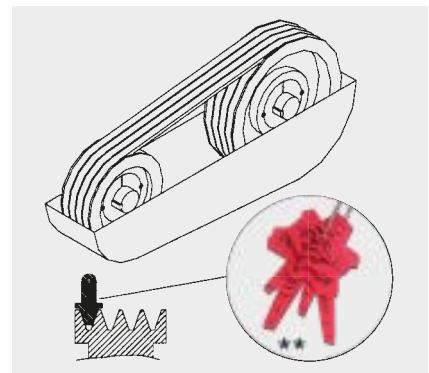

DESIGN SUPPORT

INSTALLATION AND MAINTENANCE SUPPORT

V-GROOVED PULLEYS WITH TAPER BUSHES

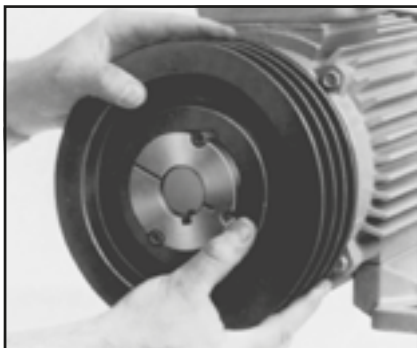
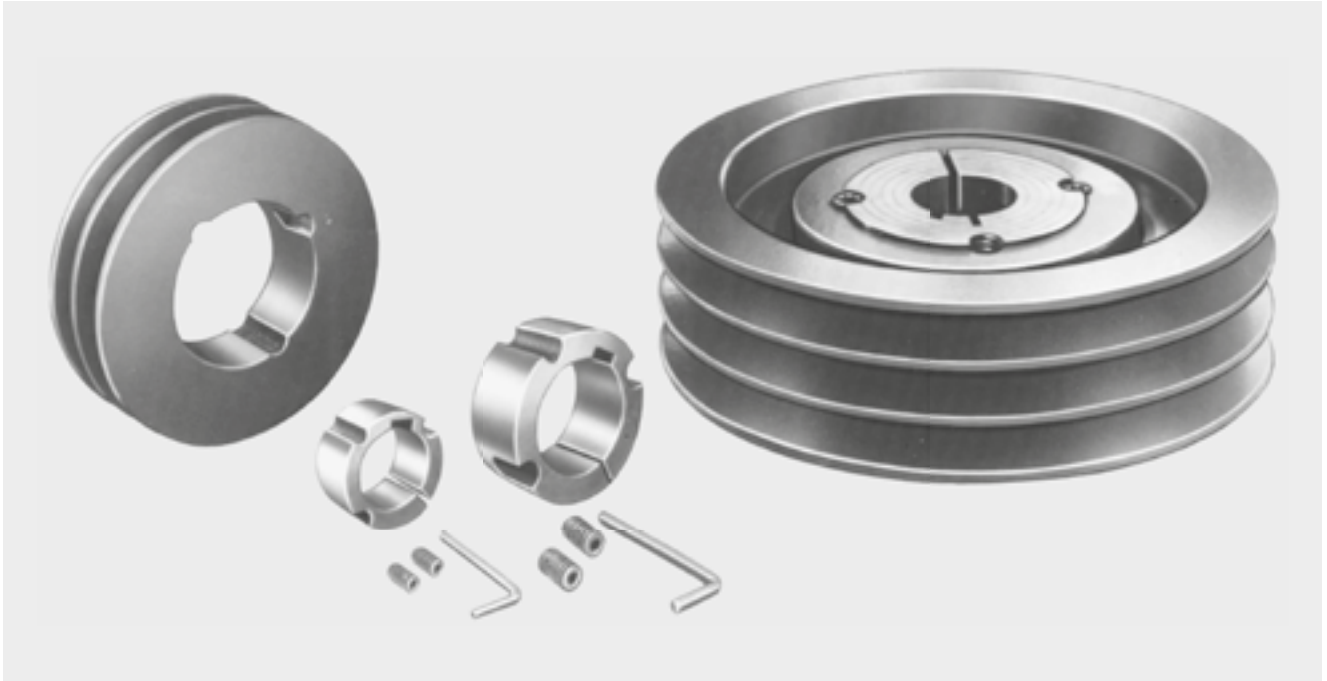

Installation

Dimension
TB 1008-3030

Dimension
TB 3525-5050

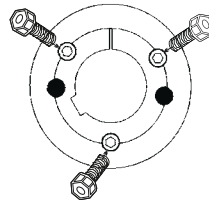
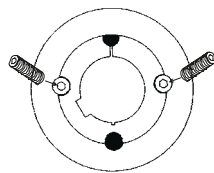

Removal

Dimension
TB 1008-3030

Dimension
TB 3525-5050

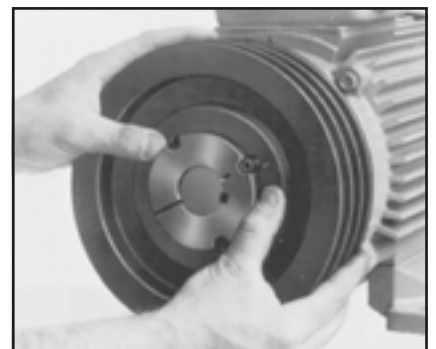
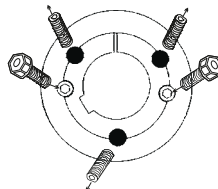
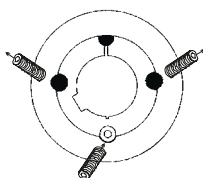

DESIGN SUPPORT

STORAGE

- **General note**

Properly stored V-belts retain their properties for many years (see also DIN 7716). However, when stored under adverse conditions or handled incorrectly, the physical properties of most rubber products will be impaired. This can be the consequence for example of the effects of oxygen, ozone, extreme temperatures, light, moisture or solvents.

- **Storage area**

The storage area should be dry and dust free. V-belts must not be stored close to chemicals, solvents, fuels, lubricants and acids etc.

- **Temperature**

V-belts should be stored at temperatures between +15 °C and +25 °C. Lower temperatures usually have no negative effect on the V-belts. However, since belts become very stiff at low temperatures, they should be warmed to approximately +20 °C before installation to avoid breaking and cracking.

Radiators and supply pipes should be screened. V-belts should be stored at least 1 m away from heat sources.

- **Light**

V-belts should be protected against light, especially direct sunlight and strong artificial light with high ultra-violet radiation (ozone formation) such as naked fluorescent tubes. Illumination using conventional bulbs is recommended.

- **Ozone**

In order to counteract the harmful effects of ozone, storages should not contain any appliances that generate ozone, e.g. fluorescent lights, mercury vapour lamps or high voltage electrical equipment. Combustion gases and vapours which could lead to the formation of ozone by photo-chemical processes must be avoided or eliminated.

- **Moisture**

Damp storage areas are unsuitable. Care must be taken to ensure that condensation does not develop. The most favourable relative air humidity is below 65%.

- **Proper storage**

Because stress can promote both permanent deformation and cracking, care must be taken to ensure that V-belts are stored without stress i.e. without tension, compression or any other form of pressure.

If V-belts have to be stored horizontally and stacked on top of each other, it is recommended that the stack height does not exceed 300 mm in order to avoid permanent deformation. If, in order to save space, V-belts are hung, the diameter of the cylinder on which the belts rest should be at least ten times the height of the belt profile.

optibelt S=C plus, optibelt SUPER E-POWER M=S, optibelt SUPER X-POWER M=S and optibelt SUPER TX M=S belts do not need to be stored in sets as they can be used in sets without measuring.

- **Cleaning**

Dirty V-belts can be cleaned using a 1:10 mixture of glycerine and methyl spirits or with brake cleaner. Petrol, benzene, turpentine and the like should not be used. In addition, sharp objects, wire brushes, emery paper etc. must be avoided under all circumstances, as these can cause damage to the belt.

DESIGN SUPPORT

PROPERTIES

This table is intended to simplify the selection of the suitable OPTIBELT drive element according to the specific drive conditions. Detailed information is given in the according chapters of this manual.	Temperature resistance from ... to ... [°C]		Oil resistance		Electrically conductive	S=C plus SetConstant ¹⁾ M=S Matched Sets ²⁾	Mining industry approval	Smooth running	Permanent stretch	
	Standard design	Special design XHR	Standard design	Special design					Standard design	Special design
SK / SK KB high performance wedge belts/ kraftbands	-40 +70	-30 +90	good	excellent	yes	yes ¹⁾	yes	medium/ good	low	very low
RED POWER 3 / KB RED POWER 3 high performance wedge belts/ kraftbands	-30 +100		good		yes	yes ¹⁾		good	very low	
BLUE POWER / KB BLUE POWER high performance wedge belts/ kraftbands										
SUPER X-POWER M=S / KBX / SUPER TX M=S raw edge, moulded cogged V-belts	-30 +90		good		yes	yes ²⁾		good	very low	
SUPER E-POWER M=S	-50 +120		limited		yes			good	very low	
MARATHON 1, MARATHON 2 M=S automotive V-belts	-30 +90		good		yes	yes ²⁾		good	very low	
VB classic V-belts	-40 +70	-30 +90	limited	excellent	yes	yes ¹⁾	yes	medium/ good	low	very low
DK double-sided V-belts	-35 +85		good		yes			medium	low	
SUPER VX / VARIO POWER variable speed belts	-30 +90		good		yes			excellent	very low	
RB ribbed belts	-30 +90	-30 +120	good		• PJ PK, PL special constructions			excellent	low	

• after testing/examination

DESIGN SUPPORT

PROPERTIES

Recommended max. belt speed m/s	Efficiency	Behaviour under shock loading	Vibration tendency	Synchronous	Recommended max. speed ratio	Suitable for outside idlers		Maintenance	Main application areas For some application areas and applications different belt types are suitable. The suitable belt is then determined individually for each case.
						Standard construction	Special construction		
≤ 42	up to 97%	good	low	no	up to 1 : 10	limited	good	low	Compressors, mixers, rotary print machines, extruders, screw compressors, weaving machines, axial fans, rotary pumps
≤ 55*	up to 97%	good	low	no	up to 1 : 10	good		maintenance-free	Fans, pumps, mixers, mills, special machines, lathes and drilling machines, grinding machines
depends on profile ≤ 55*	up to 97%	good	low	no	up to 1 : 12	limited	good	SUPER X-POWER: low maintenance	Fans, pumps, mixers, mills, special machines, lathes and drilling machines, grinding machines
≤ 55*	up to 97%	good	low	no	up to 1 : 12	limited		low maintenance	Fans, pumps, mixers, mills, special machines, lathes and drilling machines, grinding machines
≤ 42	up to 97%	good	low	no	up to 1 : 12	limited	good	low maintenance	Motor vehicles, generators, water pumps, fans
≤ 30	up to 97%	good	low	no	up to 1 : 12	limited	good	low	Pumps, presses, crushers, disk saws, box column drilling machines, plane machines, concrete mixers, compactors, lawn mowers, aerators, baling presses, shredders
≤ 30	up to 95%	good	low	no	up to 1 : 5	excellent	good	low	Special drives with changing rotary directions, weaving looms, sweepers, harvesters
depends on profile ≤ 42	up to 95%	good	low	no	up to 1 : 12 for 2 variable speed pulleys	limited		low	Special drives, compact units, snow mobile drives, multi-colour offset printing machines, variable speed pulley sets, threshing drum drives, winding machines, lathes
depends on profile ≤ 60	up to 96%	good	very low	no	up to 1 : 35	good		low	Offset machines, washing machines, milling machines, electric floor polishers, auxiliaries, main spindle drives

* v > 42 m/s. Please contact our Application Engineering Department.

DESIGN SUPPORT

PROPERTIES

<p>This table is intended to simplify the selection of the suitable OPTIBELT drive element according to the specific drive conditions. Detailed information is given in the according chapters of this manual.</p>	Temperature resistance from ... to ... [°C]		Oil resistance	Electrically conductive	Smooth running	Permanent stretch
	Standard design	Special design XHR	Standard design			
OMEGA, OMEGA HP + OMEGA HL timing belts	-30 +100	-30 +140	limited	yes•	medium/good	none
ZR timing belts	-30 +100	-30 +140	limited	yes	medium	none
ALPHA polyurethane timing belts	-30 +80		good	no	medium	none
RR round belts	-10 +80		good	no	medium	high
KK V-beltting	-10 +80		good	no	medium	high
Optimat OE open-ended V-belts, DIN 2216, punched	-20 +70		limited	no	medium	high
PKR endless timing belts with patterned top surface	-30 +70		limited	yes	medium	low
Optimax HF endless high performance flat belts	-20 +110		limited	no	excellent	low

• partly after testing/examination

DESIGN SUPPORT

PROPERTIES

Recommended max. belt speed m/s	Efficiency	Behaviour with shock loads	Vibration behaviour	Synchronous running	Recommended max. conversion	Suitable for outside idlers		Maintenance	Main application areas For some application areas and applications different belt types are suitable. The suitable belt is then determined individually for each case.
						Standard design	Special design		
depends on profile ≤ 80	up to 98%	sensitive	depends on speed	yes	up to 1 : 10	good	good	maintenance-free	Textile machines, spinning machines, weaving machines, printing machines, paper machines, woodworking machines, machine tools, linear units, roller conveyors, ski systems, packaging machines, gate and door openers, lifting devices, mixers, extruders, compressors
depends on profile ≤ 80	up to 98%	sensitive	depends on speed	yes	up to 1 : 10	good	good	maintenance-free	Copying machines, household appliances, swivel arm robots, gripper drives, belt grinders, camshaft drives, brush drives, clocks, X-Ray devices, enveloping machines, cameras, plotters, slot machines, main machines and feeders, feed drives, material feed, printers
depends on profile ≤ 80	up to 98%	sensitive	depends on speed	yes	up to 1 : 10	good	good	maintenance-free	Cameras, plotters, printers, slot machines, main machines and feeders, feed drives, material feed, test conveyance, flight models
≤ 20	up to 95%	good	low	no	up to 1 : 10	good	good	frequent retensioning	Special machinery
≤ 20	up to 95%	good	low	no	up to 1 : 10	good	good	frequent retensioning	Packaging machines, conveyor units, enamelling lines, accumulating conveyor, for difficult installation conditions
≤ 20	up to 90%	good	medium	no	up to 1 : 10	limited		frequent retensioning	Where installation conditions are difficult
depends on profile ≤ 20	up to 95%	good	low	no	up to 1 : 10	limited	good	low	Conveyor units in the wood industry, in concrete factories, in the agricultural industry, ceramic industry, glass industry, at airports, in seaports and inland ports
≤ 70	up to 95%	good	very low	no	up to 1 : 12	excellent		low	Water turbines, emergency power generators, saw gates, hackers, screw compressors, roller drives, transmission drives, conical drives, cross cutters, floor cleaners, multi-drives, crushers, close belts, hammer mills

DESIGN SUPPORT

PROBLEM – CAUSES – REMEDIES

Problem	Causes	Remedies
Belt failure shortly after installation (belt snaps)	<p>Forced installation, causing damage to the tension cord</p> <p>Entry of foreign objects during operation</p> <p>Drive undersized, not enough belts</p> <p>Drive jammed</p>	<p>Follow installation instructions for easy installation</p> <p>Fit protective guard</p> <p>Check drive design and determine new dimensions</p> <p>Remove cause</p>
Breaks and cracks in the base of the belt (brittleness)	<p>Outside idler pulley in use that does not comply with the positioning and sizes recommended by us</p> <p>Pulley diameter too small</p> <p>Excessive heat</p> <p>Excessive cold</p> <p>Excessive belt slip</p> <p>Contamination by chemicals</p>	<p>Observe OPTIBELT recommendations, e.g. increase the diameter; replace with an inside idler on the slack side of the drive; use optibelt RED POWER 3 or an OPTIBELT special design</p> <p>Re-design using recommended minimum pulley diameters; use an OPTIBELT special design, or optibelt SUPER X-POWER M=S, optibelt SUPER TX M=S</p> <p>Remove or screen heat source; improve ventilation; use optibelt SUPER X-POWER M=S, optibelt SUPER TX M=S or V-belt with aramid cord construction</p> <p>Warm the belt before operation; use OPTIBELT special design (extra cold resistant)</p> <p>Re-tension drive according to installation instructions; check drive design and re-design if necessary</p> <p>Protect drive from contamination source; use OPTIBELT special design</p>
Severe belt vibration	<p>Drive under dimensioned</p> <p>Centre distance significantly longer than recommended</p> <p>High shock load</p> <p>Belt tension too low</p> <p>Unbalanced V-pulleys</p>	<p>Check drive design and modify if necessary</p> <p>Shorten centre distance; use an inside idler in the drive slack side; re-design using optibelt KB kraftbands</p> <p>Use optibelt KB kraftbands; use an inside idler in the drive slack side; use an OPTIBELT special construction</p> <p>Correct tension</p> <p>Balance pulleys</p>
Belts cannot be re-tensioned	<p>Insufficient allowance for centre distance in drive design</p> <p>Excessive stretch caused by inadequate performance</p> <p>Incorrect belt length</p>	<p>Modify drive to allow for the OPTIBELT recommended adjustment</p> <p>Carry out drive calculation and re-design</p> <p>Use shorter belts</p>

Should other problems occur, please contact our Application Engineering Department. They will require comprehensive technical details in order to provide you with solutions.

DESIGN SUPPORT

PROBLEM – CAUSES – REMEDIES

Problem	Causes	Remedies
Belts turning over	<p>Poor drive alignment Incorrect belt/pulley groove profile Excessive wear in pulley grooves Excessive vibration</p> <p>Belt tension too low Foreign matter in the pulley grooves</p>	<p>Realign pulleys Match belt and pulley groove profile Renew pulleys Use an inside idler on drive slack side; use optibelt KB kraftbands Re-tension drive Remove foreign matter and screen drive</p>
Excessive wear on belt edges	<p>Starting torque too high Incorrect pulley groove angle Excessive pulley groove wear Incorrect belt/pulley groove profile Poor pulley alignment Pulley diameter below recommended minimum</p> <p>Belt tension too low Belt rubbing against or catching on protruding parts</p>	<p>Check drive design and re-design Re-machine or replace pulleys Replace pulleys Match belt and pulley groove profile Realign pulleys Increase pulley diameter (re-design drive); use OPTIBELT special constructions, optibelt SUPER X-POWER M=S or optibelt SUPER TX M=S Check tension and re-tension Remove protruding parts; re-position drive</p>
Excessive running noise	<p>Poor pulley alignment Belt tension too low Drive overloaded</p>	<p>Realign pulleys Check tension and re-tension Check drive design and re-design if necessary</p>
Belt swelling or softening and sticky	<p>Contamination by oil, grease, chemicals</p>	<p>Protect drive from contamination source; use optibelt SUPER X-POWER M=S or optibelt SUPER TX M=S or OPTIBELT special design 05; clean pulley grooves with petrol, alcohol or brake cleaner before installation of new belts</p>
Uneven belt stretch	<p>Worn or badly manufactured pulley grooves Used belts mixed with new belts on the drive Belts from different manufacturers used on same drive</p>	<p>Replace pulleys</p> <p>Replace with a completely new set of belts</p> <p>Belt sets must comprise belts from one manufacturer only – optibelt S=C plus, optibelt SUPER TX M=S, optibelt SUPER X-POWER M=S</p>

Should other problems occur, please contact our Application Engineering Department. They will require comprehensive technical details in order to provide you with solutions.

DESIGN SUPPORT

LENGTH TOLERANCES AND CONVERSION FACTORS

Belt length measurement

The belt is placed over two identically sized measuring pulleys of the groove design shown in the following drawings. The dimensions are given in the tables 77 to 83 on pages 161/162.

By moving to the adjustable pulley the force Q is applied on the belt. Before measuring the drive centre distance a , the belt should be rotated three times under load. This ensures that the belt is well seated in the pulley, an essential pre-condition for the accuracy of the resulting measurement.

The length is obtained by adding the diameter of the pulley to twice the drive centre distance a .

$$L_d = 2 a + U_d$$

$$L_a = 2 a + U_a$$

Length conversion factors are given in the tables on pages 161/162 and 165/166.

Arrangement for measuring belt length

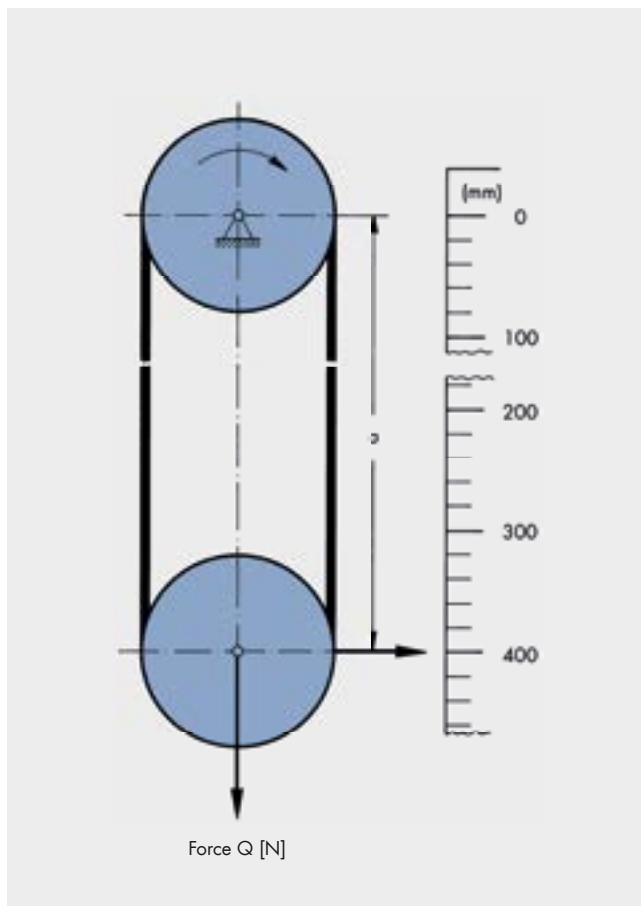

Measuring pulley for wedge belts DIN 7753 Part 1 and classic V-belts DIN 2215

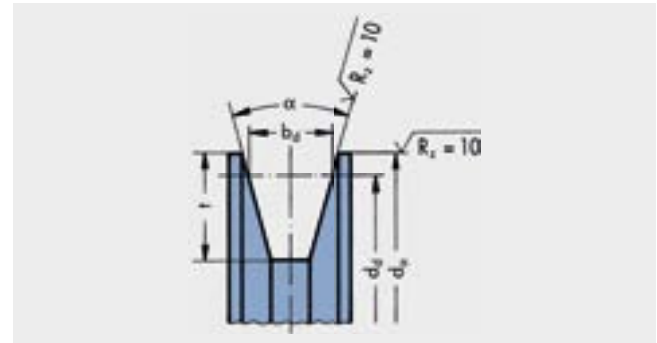

Measuring pulley for wedge belts USA standard RMA/MPTA

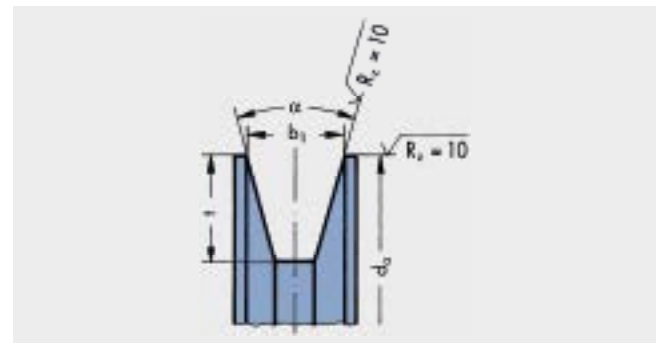

Measuring pulley for kraftbands

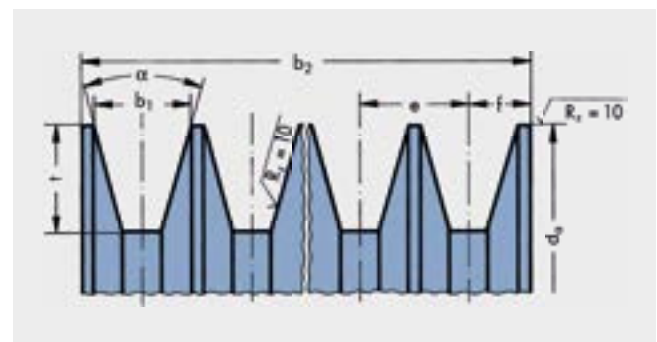

Measuring pulley for double-sided V-belts

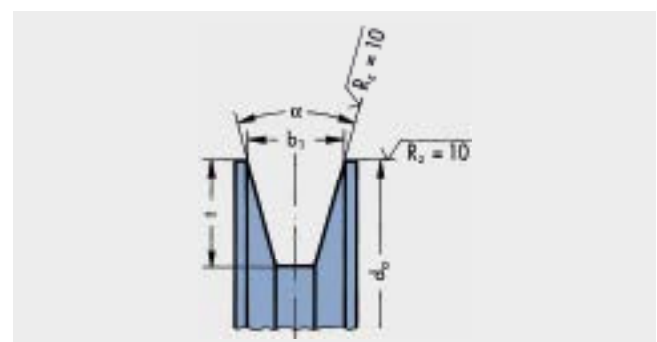

DESIGN SUPPORT

LENGTH MEASUREMENT CONDITIONS AND CONVERSION FACTORS

Table 77: optibelt SK high performance wedge belts
 optibelt SUPER X-POWER M=S wedge belts – raw edge, moulded cogged
 optibelt SUPER E-POWER M=S high performance wedge belts – raw edge, moulded cogged
 Measuring pulleys and force according to DIN 7753 Part 1 and ISO 4183

Profile	Datum circumference U_d $= d_d \cdot \pi$	Datum diameter d_d ± 0.05	Outside diameter d_a ± 0.05	Datum width b_d	Groove angle α° $\pm 10'$	Groove depth t_{min}	Measuring force Q [N]	Outside length L_a [mm]	Inside length L_i [mm]
SPZ; XPZ	300	95.49	100	8.50	36	11	360	$L_a \approx L_d + 13$ $L_a \approx L_i + 51$	$L_i \approx L_d - 38$ $L_i \approx L_a - 51$
SPA; XPA	450	143.24	149	11.00	36	14	560	$L_a \approx L_d + 18$ $L_a \approx L_i + 63$	$L_i \approx L_d - 45$ $L_i \approx L_a - 63$
SPB; XPB	600	190.99	198	14.00	36	18	900	$L_a \approx L_d + 22$ $L_a \approx L_i + 82$	$L_i \approx L_d - 60$ $L_i \approx L_a - 82$
SPC; XPC	1000	318.31	328	19.00	36	24	1500	$L_a \approx L_d + 30$ $L_a \approx L_i + 113$	$L_i \approx L_d - 83$ $L_i \approx L_a - 113$

Table 78: optibelt SK high performance wedge belts
 optibelt SUPER X-POWER M=S wedge belts – raw edge, moulded cogged
 optibelt SUPER E-POWER M=S high performance wedge belts – raw edge, moulded cogged
 Measuring pulleys and force according to USA standard RMA/MPTA

Profile	Outside circumference U_a $= d_a \cdot \pi$	Outside diameter d_a ± 0.13	Upper groove width b_1 ± 0.13	Groove angle α° $\pm 15'$	Groove depth t_{min}	Measuring force Q [N]	Inside length L_i [mm]
3V/9N; 3VX/9NX	300	95.50	8.90	38	9.00	445	$L_i \approx L_a - 42$
5V/15N; 5VX/15NX	600	191.00	15.24	38	15.00	1000	$L_i \approx L_a - 71$
8V/25N	1000	318.30	25.40	38	25.50	2225	$L_i \approx L_a - 120$

Table 79: optibelt VB classic V-belts
 optibelt SUPER TX M=S classic V-belts – raw edge, moulded cogged
 Measuring pulleys and force according to DIN 2215 und ISO 4183

Profile	Datum circumference U_d $= d_d \cdot \pi$	Datum diameter d_d ± 0.05	Outside diameter d_a ± 0.05	Datum width b_d	Groove angle α° $\pm 10'$	Groove depth t_{min}	Measuring force Q [N]	Outside length L_a [mm]	Datum length L_d [mm]
5	70	22.28	24.88	4.20	32	5	30	$L_a \approx L_i + 19$ $L_a \approx L_d + 8$	$L_d \approx L_i + 11$ $L_d \approx L_a - 8$
Y/6	90	28.65	31.85	5.30	32	6	40	$L_a \approx L_i + 25$ $L_a \approx L_d + 10$	$L_d \approx L_i + 15$ $L_d \approx L_a - 10$
8	140	44.56	48.56	6.70	32	8	80	$L_a \approx L_i + 31$ $L_a \approx L_d + 12$	$L_d \approx L_i + 19$ $L_d \approx L_a - 12$
Z/10; ZX/X10	180	57.30	62.30	8.50	34	10	110	$L_a \approx L_i + 38$ $L_a \approx L_d + 16$	$L_d \approx L_i + 22$ $L_d \approx L_a - 16$
A/13; AX/X13	300	95.50	102.10	11.00	34	12	200	$L_a \approx L_i + 50$ $L_a \approx L_d + 20$	$L_d \approx L_i + 30$ $L_d \approx L_a - 20$
B/17; BX/X17	400	127.32	135.72	14.00	34	15	300	$L_a \approx L_i + 69$ $L_a \approx L_d + 29$	$L_d \approx L_i + 40$ $L_d \approx L_a - 29$
20	520	165.52	175.12	17.00	34	18	750	$L_a \approx L_i + 79$ $L_a \approx L_d + 31$	$L_d \approx L_i + 50$ $L_d \approx L_a - 31$
C/22; CX/X22	700	222.82	234.22	19.00	34	20	750	$L_a \approx L_i + 88$ $L_a \approx L_d + 30$	$L_d \approx L_i + 58$ $L_d \approx L_a - 30$
25	800	254.65	267.25	21.00	34	22	750	$L_a \approx L_i + 100$ $L_a \approx L_d + 39$	$L_d \approx L_i + 60$ $L_d \approx L_a - 39$
D/32	1000	318.31	334.52	27.00	36	28	1400	$L_a \approx L_i + 126$ $L_a \approx L_d + 51$	$L_d \approx L_i + 75$ $L_d \approx L_a - 51$
E/40	1800	572.96	596.96	32.00	36	36	1800	$L_a \approx L_i + 157$ $L_a \approx L_d + 77$	$L_d \approx L_i + 80$ $L_d \approx L_a - 77$

DESIGN SUPPORT

LENGTH MEASUREMENT CONDITIONS AND CONVERSION FACTORS

Table 80: optibelt KB kraftbands with high performance wedge belts
Measuring pulleys and force

Profile	Outside circumference $U_a = d_a \cdot \pi$	Outside diameter $d_a \pm 0.13$	Upper groove width $b_1 \pm 0.13$	Groove angle $\alpha^\circ \pm 15'$	Groove depth t_{\min}	Groove pitch e	Tolerance $e^{1)}$	Σ Tol. $e^{2)}$	Force per rib Q [N]	Inside length L_i [mm]
3V/9J	300	95.50	8.90	38	9.00	10.30	± 0.25	± 0.5	445	$L_i \approx L_a - 42$
5V/15J	600	191.00	15.20	38	15.00	17.50	± 0.25	± 0.5	1000	$L_i \approx L_a - 71$
8V/25J	1000	318.30	25.40	38	25.50	28.60	± 0.40	± 0.8	2225	$L_i \approx L_a - 120$

Table 81: optibelt KB kraftbands
Measuring pulleys and force

Profile	Datum circumference $U_d = d_d \cdot \pi$	Datum diameter $d_d \pm 0.13$	Outside diameter $d_a \pm 0.13$	Datum width b_d	Groove angle $\alpha^\circ \pm 15'$	Groove depth t_{\min}	Groove pitch e	Tolerance $e^{1)}$	Σ Tol. $e^{2)}$	Force per rib Q [N]	Datum length L_d [mm]
SPZ	300	95.49	100.00	8.50	36	11.00	12.00	± 0.30	± 0.5	360	$L_d \approx L_a - 13$
SPA	450	143.24	149.00	11.00	36	14.00	15.00	± 0.30	± 0.5	560	$L_d \approx L_a - 18$
SPB	600	190.99	198.00	14.00	36	18.00	19.00	± 0.40	± 0.8	900	$L_d \approx L_a - 22$
SPC	1000	318.31	328.00	19.00	36	24.00	25.50	± 0.40	± 0.8	1500	$L_d \approx L_a - 30$

Table 82: optibelt KB kraftbands with classic V-belts
Measuring pulleys and force

Profile	Outside circumference $U_a = d_a \cdot \pi$	Outside diameter $d_a \pm 0.13$	Upper groove width $b_1 \pm 0.13$	Groove angle $\alpha^\circ \pm 15'$	Groove depth t_{\min}	Groove pitch e	Tolerance $e^{1)}$	Σ Tol. $e^{2)}$	Force per rib Q [N]	Inside length L_i [mm]
A/HA	254	80.85	12.45	32	12.50	15.88	± 0.38	± 0.8	300	$L_i \approx L_a - 36$
B/HB	381	121.28	16.00	32	14.50	19.05	± 0.38	± 0.8	450	$L_i \approx L_a - 62$
C/HC	635	202.13	22.33	34	20.00	25.40	± 0.38	± 0.8	850	$L_i \approx L_a - 75$
D/HD	889	282.96	31.98	34	28.00	36.53	± 0.38	± 0.8	1000	$L_i \approx L_a - 111$

1) Tolerance for the medium distance e between two adjacent grooves

2) Sum of all deviations from the nominal size e for all groove distances on one pulley must not exceed the given values.

Table 83: optibelt DK double-sided V-belts
Measuring pulleys and force according to ISO 5289

Profile	Outside circumference $U_a = d_a \cdot \pi$	Outside diameter d_a	Upper groove width b_1	Groove angle $\alpha^\circ \pm 20'$	Groove depth t_{\min}	Measuring force Q [N]
AA/HAA	300	95.49	12.60	34	8	300
BB/HBB	400	127.32	16.20	34	10	450
CC/HCC	600	190.99	22.30	34	14	850
DD/HDD	900	286.48	32.00	34	20	1400
22 x 22	600	190.99	22.30	34	14	750
25 x 22	942	300.00	25.00	34	22	1200

DESIGN SUPPORT

LENGTH TOLERANCES

Table 84: Endless wedge belts DIN 7753 Part 1

Profile	Datum length [mm]	Length tolerance [mm] Allowed deviation of the datum lengths		Set tolerances [mm] Allowed deviation between datum lengths L_d of the belts in one and the same set on multi-grooved belt drives			
		OPTIBELT		OPTIBELT		DIN 7753/ISO 4184	
		wrapped	DIN 7753	wrapped	raw edge	wrapped	raw edge
SPZ/XPZ SPA/XPA SPB/XPB SPC/XPC	> 630 ≤ 900	DIN	± 6 to ± 9	2	2	2	2
	> 900 ≤ 1250	DIN	± 9 to ± 12	2	4	2	4
	> 1250 ≤ 2000	± 2	± 12 to ± 20	± 2	6	2	6
	> 2000 ≤ 3150	± 2	± 20 to ± 32	± 2	6	4	6
	> 3150 ≤ 5000*	± 2	± 32 to ± 50	± 2	10*	6	10*
	> 5000 ≤ 8000	± 4	± 50 to ± 80	± 4		10	
	> 8000 ≤ 10000	± 6	± 80 to ± 100	± 6		16	
> 10000 ≤ 12500	± 8	± 100 to ± 125	± 8				

Table 85: Classic V-belts DIN 2215

Profile	Datum length [mm]	Length tolerance [mm] Allowed deviation of the datum lengths		Set tolerances [mm] Allowed deviation between datum lengths L_d of the belts in one and the same set on multi-grooved belt drives			
		OPTIBELT		OPTIBELT		DIN 2215/ISO 4184	
		wrapped	DIN 2215	wrapped	raw edge	wrapped	raw edge
5 Y/6 8 Z/10; ZX/X10 A/13; AX/X13 B/17; BX/X17 20 C/22; CX/X22 25 D/32 E/40	≤ 250	DIN	+ 8/- 4	2		2	2
	> 250 ≤ 315	DIN	+ 9/- 4	2		2	2
	> 315 ≤ 400	DIN	+ 10/- 5	2		2	2
	> 400 ≤ 500	DIN	+ 11/- 6	2		2	2
	> 500 ≤ 630	DIN	+ 13/- 6	2	2	2	2
	> 630 ≤ 800	DIN	+ 15/- 7	2	2	2	2
	> 800 ≤ 900	DIN	+ 17/- 8	2	2	2	2
	> 900 ≤ 1250	DIN	+ 19/- 10	4	4	4	4
	> 1250 ≤ 1600	± 2	+ 23/- 11	± 2	4	4	4
	> 1600 ≤ 2000	± 2	+ 27/- 13	± 2	4	4	4
	> 2000 ≤ 2500	± 2	+ 31/- 16	± 2	6	8	8
	> 2500 ≤ 3150	± 2	+ 37/- 18	± 2	8	8	8
	> 3150 ≤ 4000*	± 2	+ 44/- 22	± 2	8*	12	12*
	> 4000 ≤ 5000	± 2	+ 52/- 26	± 2		12	
	> 5000 ≤ 6300	± 4	+ 63/- 32	± 4		20	
	> 6300 ≤ 8000	± 4	+ 77/- 38	± 4		20	
	> 8000 ≤ 10000	± 6	+ 93/- 46	± 6		32	
	> 10000 ≤ 12500	± 8	+ 112/- 56	± 8		32	
	> 12500 ≤ 15000	DIN	+ 140/- 70	DIN		48	
	> 15000 ≤ 20000	DIN	+ 170/- 85	DIN		48	

* Maximum production length for raw edge V-belts ≤ 3550 mm

optibelt S=C plus and optibelt M=S V-belts can be used in sets without measuring.

DESIGN SUPPORT

LENGTH TOLERANCES

Table 86: Endless wedge belts USA standard RMA/MPTA

Profile	Length designation	Outside length [mm]	Length tolerance [mm]		Set tolerance [mm]		
			Allowed deviation from outside lengths Replace complete belt sets!		Allowed deviation between the outside lengths L_o of the belts in one and the same set on multi-grooved belt drives Replace complete belt sets!		
			OPTIBELT wrapped	RMA/MPTA	OPTIBELT wrapped	raw edge	RMA/MPTA
3V/9N 3VX/9NX 5V/15N 5VX/15NX 8V/25N	265 ≤ 500	673 ≤ 1270	acc. RMA/MPTA	± 8	4	4	4
	530	1346	± 2	± 10	± 2	4	4
	560	1422	± 2	± 10	± 2	6	6
	600 ≤ 800	1524 ≤ 2032	± 2	± 10	± 2	6	6
	800 ≤ 1000	2032 ≤ 2540	± 2	± 13	± 2	6	6
	1000 ≤ 1060	2540 ≤ 2692	± 2	± 15	± 2	6	6
	1120 ≤ 1400	2845 ≤ 3556	± 2	± 15	± 2	10*	10
	1500 ≤ 1900	3810 ≤ 4826	± 2	± 20	± 2		10
	2000 ≤ 2360	5080 ≤ 5994	± 4	± 20	± 4		10
	2500 ≤ 3000	6350 ≤ 7620	± 4	± 20	± 4		16
	3150 ≤ 3750	8001 ≤ 9525	± 6	± 25	± 6		16
	4000	10160	± 8	± 25	± 8		16
	4250 ≤ 4500	10795 ≤ 11430	± 8	± 30	± 8		16
	4750 ≤ 5000	12065 ≤ 12700	± 12	± 30	± 12		24

Table 87: Double-sided V-belts

Profile	Reference length [mm]	Length tolerance [mm]	Set tolerance [mm]
		Allowed deviation of the reference lengths	Allowed deviation between the reference length of the double-sided V-belts in one and the same set on multi-grooved belt drives
AA/HAA BB/HBB CC/HCC DD/HDD 22 x 22 25 x 22	1250 < 1320	+ 8/- 16	4
	1320 < 1700	+ 9/- 18	4
	1700 < 2120	+ 11/- 22	5
	2120 < 2650	+ 13/- 26	6.3
	2650 < 3350	+ 15/- 30	8
	3350 < 4250	+ 18/- 36	10
	4250 < 5300	+ 22/- 44	12.5
	5300 < 6700	+ 26/- 52	16
	6700 < 8500	+ 32/- 64	20
8500 < 10000	+ 39/- 78	25	

Table 88: Kraftbands with high performance wedge belts and classic V-belts

Profile	Length and set tolerances
3V/9J; 3VX/9JX 5V/15J; 5VX/15JX 8V/25J	USA standard RMA/MPTA
SPZ; SPA; SPB; SPC	DIN/ISO
A/HA B/HB C/HC D/HD	DIN/ASAE

* Maximum production length for raw edge V-belts ≤ 3550 mm

TABLES

CONVERSION FACTORS

optibelt SK high performance wedge belts DIN 7753 Part 1

Profile	Cross-section b x h ≈	Bottom belt width b _v ≈	Nominal width b _d	Belt length			Recommended minimum pulley diameter [mm]	Meter weight (≈ kg/m)		
				Nominal length L _d	Outside length L _o	Pitch length L _d			Inside length L _i	
SPZ	9.7 x 8	4.2	8.5	Nominal length L _d	L _o ≈ L _d + 13 L _o ≈ L _i + 51	—	L _i ≈ L _d - 38 L _i ≈ L _o - 51	Nominal diameter d _d	63	0.074
SPA	12.7 x 10	5.8	11.0		L _o ≈ L _d + 18 L _o ≈ L _i + 63	—	L _i ≈ L _d - 45 L _i ≈ L _o - 63		90	0.123
SPB	16.3 x 13	7.3	14.0		L _o ≈ L _d + 22 L _o ≈ L _i + 82	—	L _i ≈ L _d - 60 L _i ≈ L _o - 82		140	0.195
SPC	22.0 x 18	9.6	19.0		L _o ≈ L _d + 30 L _o ≈ L _i + 113	—	L _i ≈ L _d - 83 L _i ≈ L _o - 113		224	0.377

optibelt SK high performance wedge belts USA standard RMA/MPTA

Profile	Cross-section b x h ≈	Bottom belt width b _v ≈	Nominal width b _d	Outside length L _o	Pitch length L _d	Inside length L _i	Outside diameter d _o	Meter weight (≈ kg/m)
3V/9N	9.0 x 8	4.2	—	—	L _d ≈ L _o - 4*	L _i ≈ L _o - 42	67	0.074
5V/15N	15.0 x 13	7.3	—		L _d ≈ L _o - 11*	L _i ≈ L _o - 71	151	0.195
8V/25N	25.0 x 23	9.6	—		—	L _i ≈ L _o - 120	315	0.575

* The conversion factor L_d to L_o is used when a profile according to DIN 7753 Part 1 is to be replaced by the corresponding profile according to RMA/MPTA.

optibelt SUPER X-POWER M=S wedge belts - raw edge, moulded cogged - DIN 7753 Part 1

optibelt SUPER E-POWER M=S high performance wedge belts - raw edge, moulded cogged - DIN 7753 Part 1

Profile	Cross-section b x h ≈	Bottom belt width b _v ≈	Nominal width b _d	Nominal length L _d	Outside length L _o	Pitch length L _d	Inside length L _i	Nominal diameter d _d	Meter weight (≈ kg/m)
XPZ	9.7 x 8	4.2	8.5	Nominal length L _d	L _o ≈ L _d + 13 L _o ≈ L _i + 51	—	L _i ≈ L _d - 38 L _i ≈ L _o - 51	56	0.065
XPA	12.7 x 10	5.8	11.0		L _o ≈ L _d + 18 L _o ≈ L _i + 63	—	L _i ≈ L _d - 45 L _i ≈ L _o - 63	71	0.111
XPB	16.3 x 13	7.3	14.0		L _o ≈ L _d + 22 L _o ≈ L _i + 82	—	L _i ≈ L _d - 60 L _i ≈ L _o - 82	112	0.183
XPC	22.0 x 18	9.6	19.0		L _o ≈ L _d + 30 L _o ≈ L _i + 113	—	L _i ≈ L _d - 83 L _i ≈ L _o - 113	180	0.340

optibelt SUPER X-POWER M=S wedge belts - raw edge, moulded cogged - USA standard RMA/MPTA

optibelt SUPER E-POWER M=S high performance wedge belts - raw edge, moulded cogged - USA standard RMA/MPTA

Profile	Cross-section b x h ≈	Bottom belt width b _v ≈	Nominal width b _d	Outside length L _o	Pitch length L _d	Inside length L _i	Outside diameter d _o	Meter weight (≈ kg/m)
3VX/9NX	9.0 x 8	4.2	—	—	L _d ≈ L _o - 4*	L _i ≈ L _o - 42	56	0.065
5VX/15NX	15.0 x 13	7.3	—		L _d ≈ L _o - 11*	L _i ≈ L _o - 71	112	0.183

* The conversion factor L_d to L_o is used when a profile according to DIN 7753 Part 1 is to be replaced by the corresponding profile according to RMA/MPTA.

optibelt SUPER TX M=S V-belts - raw edge, moulded cogged

Profile	Cross-section b x h ≈	Bottom belt width b _v ≈	Nominal width b _d	Nominal length L _d	Outside length L _o	Pitch length L _d	Inside length L _i	Nominal diameter d _d	Meter weight (≈ kg/m)
ZX/X10	10.0 x 6	5.9	8.5	Nominal length L _d	L _o ≈ L _i + 38 L _o ≈ L _d + 16	—	L _i ≈ L _d - 22 L _i ≈ L _o - 38	40	0.062
AX/X13	13.0 x 8	7.5	11.0		L _o ≈ L _i + 50 L _o ≈ L _d + 20	—	L _i ≈ L _d - 30 L _i ≈ L _o - 50	63	0.099
BX/X17	17.0 x 11	9.4	14.0		L _o ≈ L _i + 69 L _o ≈ L _d + 29	—	L _i ≈ L _d - 40 L _i ≈ L _o - 69	90	0.165
CX/X22	22.0 x 14	12.3	19.0		L _o ≈ L _i + 88 L _o ≈ L _d + 30	—	L _i ≈ L _d - 58 L _i ≈ L _o - 88	140	0.276

optibelt VB classic V-belts DIN 2215

Profile	Cross-section b x h ≈	Bottom belt width b _v ≈	Nominal width b _d	Nominal length L _d	Outside length L _o	Pitch length L _d	Inside length L _i	Nominal diameter d _d	Meter weight (≈ kg/m)
5	5.0 x 3	2.8	4.2	Nominal length L _d	L _o ≈ L _i + 19 L _o ≈ L _d + 8	L _d ≈ L _i + 11 L _d ≈ L _o - 8	—	20	0.018
Y/6	6.0 x 4	3.3	5.3		L _o ≈ L _i + 25 L _o ≈ L _d + 10	L _d ≈ L _i + 15 L _d ≈ L _o - 10	—	28	0.026
8	8.0 x 5	4.5	6.7		L _o ≈ L _i + 31 L _o ≈ L _d + 12	L _d ≈ L _i + 19 L _d ≈ L _o - 12	—	40	0.042
Z/10	10.0 x 6	5.9	8.5		L _o ≈ L _i + 38 L _o ≈ L _d + 16	L _d ≈ L _i + 22 L _d ≈ L _o - 16	—	50	0.064
A/13	13.0 x 8	7.5	11.0		L _o ≈ L _i + 50 L _o ≈ L _d + 20	L _d ≈ L _i + 30 L _d ≈ L _o - 20	—	71	0.109
B/17	17.0 x 11	9.4	14.0		L _o ≈ L _i + 69 L _o ≈ L _d + 29	L _d ≈ L _i + 40 L _d ≈ L _o - 29	—	112	0.196
20	20.0 x 12.5	11.4	17.0		L _o ≈ L _i + 79 L _o ≈ L _d + 31	L _d ≈ L _i + 50 L _d ≈ L _o - 31	—	160	0.266
C/22	22.0 x 14	12.3	19.0		L _o ≈ L _i + 88 L _o ≈ L _d + 30	L _d ≈ L _i + 58 L _d ≈ L _o - 30	—	180	0.324
25	25.0 x 16	14.0	21.0		L _o ≈ L _i + 100 L _o ≈ L _d + 39	L _d ≈ L _i + 60 L _d ≈ L _o - 39	—	250	0.420
D/32	32.0 x 20	18.2	27.0		L _o ≈ L _i + 126 L _o ≈ L _d + 51	L _d ≈ L _i + 75 L _d ≈ L _o - 51	—	355	0.668
E/40	40.0 x 25	22.8	32.0		L _o ≈ L _i + 157 L _o ≈ L _d + 77	L _d ≈ L _i + 80 L _d ≈ L _o - 77	—	500	0.958

TABLES

CONVERSION FACTORS

optibelt KB kraftbands with wedge belts to ISO 5290/USA standard RMA/MPTA

Profile	Height $h \approx$	Bottom belt width $b_u \approx$ of the single belt	Belt length				Recommended minimum pulley diameter [mm]	Meter weight per rib (\approx kg/m)	
			Nominal length	Outside length L_o	Datum length L_d	Inside length L_i			
3V/9J	9.9	4.2	Outside length L_o	—	—	$L_i \approx L_o - 42$	Outside diameter d_o	84	0.122
5V/15J	15.1	7.3		—	—	$L_i \approx L_o - 71$		191	0.252
8V/25J	25.5	9.6		—	—	$L_i \approx L_o - 120$		355	0.693

optibelt KB kraftbands with high performance wedge belts

Profile	Height $h \approx$	Bottom belt width $b_u \approx$	Datum length L_d	$L_o \approx L_d + 13$	—	—	Datum diameter d_d	80	0.120
SPZ	10.5	5.4		$L_o \approx L_d + 18$	—	—		112	0.166
SPA	12.5	7.0		$L_o \approx L_d + 22$	—	—		180	0.261
SPB	15.6	8.8		$L_o \approx L_d + 24$	—	—		250	0.555
SPC	22.6	9.3							

optibelt KB kraftbands with classic V-belts

Profile	Height $h \approx$	Bottom belt width $b_u \approx$	Datum length L_d	$L_o \approx L_i + 36$	$L_d \approx L_i + 30$	—	Datum diameter d_d	80	0.163
A	9.9	7.5		$L_o \approx L_i + 62$	$L_d \approx L_i + 40$	—		125	0.266
B	13.0	9.4		$L_o \approx L_i + 75$	$L_d \approx L_i + 58$	—		200	0.447
C	16.2	12.3		$L_o \approx L_i + 111$	$L_d \approx L_i + 75$	—		355	0.798
D	22.4	18.2							

optibelt KB kraftbands according to USA standard ASAE S 211. ...

Profile	Height $h \approx$	Bottom belt width $b_u \approx$	Outside length L_o	—	—	$L_i \approx L_o - 36$	Outside diameter d_o	80	0.163
HA	9.9	7.5		—	—	$L_i \approx L_o - 62$		125	0.266
HB	13.0	9.4		—	—	$L_i \approx L_o - 75$		200	0.447
HC	16.2	12.3		—	—	$L_i \approx L_o - 111$		355	0.798
HD	22.4	18.2							

The width of the kraftband is dependent upon the number of ribs.

optibelt DK double-sided V-belts to DIN 7722/ISO 5289

Profile	Cross-section $b \times h \approx$	Bottom belt width $b_u \approx$	Nominal length	Belt length			Recommended minimum pulley diameter [mm]	Meter weight (\approx kg/m)	
AA/HAA	13 x 10	—	Reference length	Reference length \approx centre length - 4			Outside diameter d_o	80	0.150
BB/HBB	17 x 13	—		Reference length \approx centre length - 8				125	0.250
CC/HCC	22 x 17	—		Reference length \approx centre length + 3				224	0.440
DD/HDD	32 x 25	—		Reference length = centre length				355	0.935

optibelt DK double-sided V-belts – special profiles

22 x 22	22 x 22	—	Reference length	Reference length = centre length			Outside diameter d_o	280	0.511
25 x 22	25 x 22	—		Reference length = centre length				280	0.625

optibelt MARATHON 1/MARATHON 2 M=S automotive V-belts

Profile	Cross-section $b \times h \approx$	Bottom belt width $b_u \approx$	Nominal width b_d	Belt length			Recommended minimum pulley diameter [mm]	Meter weight (\approx kg/m)
				Nominal length	v L_d	Inside length L_i		
AVX 10/9.5	10 x 8	4.9	8.5	Outside length L_o	$L_d \approx L_o - 18$	$L_i \approx L_o - 51$	According to agreement and check with automotive industry	0.076
AVX 13/12.5	13 x 10	5.8	11.0		$L_d \approx L_o - 18$	$L_i \approx L_o - 63$		0.118
15A	16.6 x 10.4	9.2	—		$L_d \approx L_o - 0$	$L_i \approx L_o - 65$	76	0.139
17A	18.2 x 10.8	10.6	—		$L_d \approx L_o - 10$	$L_i \approx L_o - 68$	76	0.157
20A	21.4 x 12.4	12.6	—		$L_d \approx L_o - 20$	$L_i \approx L_o - 78$	89	0.236

CONVEYOR ELEMENTS

PRODUCT DESCRIPTION

OPTIBELT has developed a series of conveyor elements for the economical conveyance of goods in a varied range of applications.

- optibelt PKR endless V-belts DIN 2215 with patterned top surfaces
- optibelt PKR endless V-belts DIN 2215 with light coloured fabric cover and patterned top surfaces within the standard belt height
- optibelt KB kraftbands with patterned top surfaces
- optimat PKR open-ended V-belts DIN 2216 with patterned top surfaces
- optimat FK open-ended conveyor belts, punched
- optimax HF high performance flat belts

Construction/Quality

OPTIBELT conveyor elements consist of the basic belt and the top surface. These parts are specially connected via vulcanisation. The variety of applications required constructions with numerous patterns available in different qualities. Both pattern and surface quality should be adapted to the individual application.

Table 89

Type/Colour	Temperature resistance (°C)	Hardness (Shore A)	Oil resistance	Loss of colour
SBR-NR/light	-40 to + 70	55*/65**	no	no
CR/black	-25 to +100	≈ 65	limited	yes

CR/black is available as standard. We would be pleased to inform you about the production of the other constructions.

SBR = Styrene-Butadiene-Rubber

NR = Natural Rubber

CR = Chloroprene Rubber

* ≈ 55 for top surfaces above the standard height

** ≈ 65 for top surfaces within the standard height

Properties

Special surfaced belts are used instead of expensive conventional type conveyor belts. They run individually, or in sets arranged adjacent to each other, transporting goods horizontally, or inclined up or down. Vertical conveying is also possible if the belts are arranged top surface to top surface, gripping the goods between them.

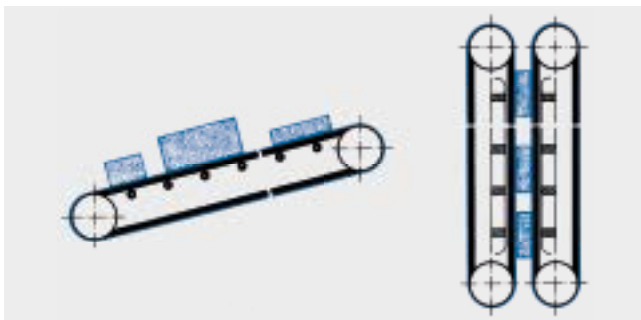

Applications

Here are just a few examples of the wide range of applications in which OPTIBELT conveyor belts are used successfully.

For the conveyance of:

- doors, cupboard parts, veneer and plastic panels in the woodworking industry
- body parts and sharp-edged sheet metal in the automotive industry
- cardboard and boxes in the packaging industry
- roof tiles, concrete slabs and block paving stones
- flat glass
- postal items
- bowling balls on bowling lanes

In addition to the conveyance options, these belts are also used for

- labelling and sealing of tins and jars in the canning industry
- lifting, chopping and sorting of beet, potatoes, salad, cauliflower, Brussels sprouts and other vegetables in the agricultural industry

Due to their single belt characteristics and high surface load, OPTIBELT kraftbands with patterned top surfaces are especially suitable in conveyor systems and lifting platforms for:

- the conveyance of cargo containers
- loading and clearing of airplanes and railway wagons
- stowing and unloading of ship cargos

optibelt KB with top surface



CONVEYOR ELEMENTS

DESIGN GUIDELINES

Drive and guide pulleys

The drive and guide pulleys should be V-grooved pulleys. The minimum diameters should be selected according to the standard recommendations for V-belts and kraftbands. See the chapter on V-grooved pulleys. Due to the relatively low transporting speed (experience has shown that it is usually less than 1m/s) and the resulting low flex rate, pulley diameters can be reduced to approximately 10% below the recommended minimum. With greater reduction, there is danger that the top surface separates from the V-belt base. The driver pulley should be arranged at the discharge end of the conveyor so that the goods are pulled along.

Support idlers/tracks

In most cases, support idlers or tracks are required to prevent the belt from sagging under load. Support idlers may be flat faced or V-grooved pulleys. The dimensions of the pulley grooves should support the base of the conveyor belt in the base of the groove so only one edge can run on the groove flank, and thus cannot get stuck in the groove.

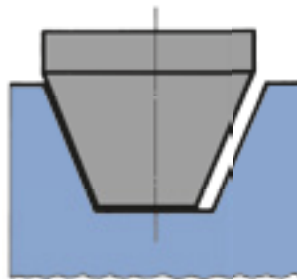

The diameter and the number of support idlers required depend on the length of the conveying span and the weight and size of the goods to be conveyed. Supporting tracks, generally made of plastic, are either flat or with a key seat to improve guidance of the conveyor belt. As with the support idlers, the grooves must have an adequate width.

Adjustment of the drive centre distance allowances

The tables on pages 82 to 84 show the drive centre distance allowances for special purpose conveyor belts and kraftbands.

Tensioning options

An adequate belt tension is essential to the reliable operation of the conveyor system. Tension is applied by adjusting the drive centre distance or, when the centres are fixed, by tension idlers.

When idlers are employed, they should be arranged inside the belt if possible, as otherwise the alternating flexing of the belt will reduce its service life.

optibelt KB KRAFTBANDS WITH PATTERNED TOP SURFACE

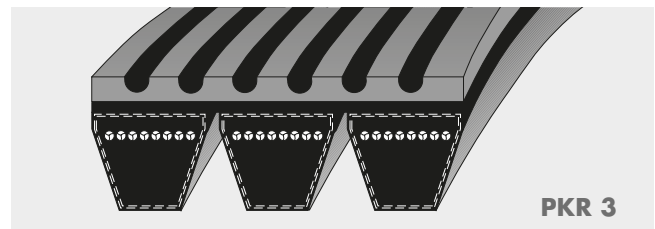
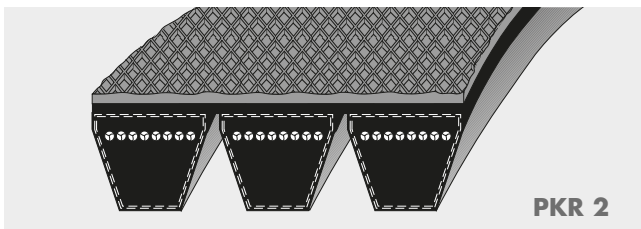

Pattern type	Top surface height		Pitch [mm]	Groove width [mm]
	standard [mm]	maximum [mm]		
PKR 0	3	5	—	—
PKR 1	3	5	10	—
PKR 2	3	5	—	—
PKR 3	5	—	—	3.7

Type/Colour	Temperature resistance [°C]	Hardness (Shore A)	Oil resistance	Loss of colour
SBR-NR/light	-40 to + 70	≈ 55	no	no
CR/black	-25 to +100	≈ 65	limited	yes

SBR = Styrene-Butadiene-Rubber
 NR = Natural Rubber
 CR = Chloroprene Rubber

Table 90

Profile	Cross-sectional dimensions of the belt [mm]	Kraftband height without top surface [mm]	Length designation	Length [mm]	Maximum production length [mm]	Pattern type			
						PKR 0	PKR 1	PKR 2	PKR 3
3V/9J	9 x 8	9.9	500 ≤ 1400	1400 ≤ 3556 L _a	4250	•	•	•	—
5V/15J	15 x 13	15.1	500 ≤ 3550	1400 ≤ 9017 L _a	10000	•	•	•	—
8V/25J	25 x 23	25.5	1000 ≤ 4750	2540 ≤ 12065 L _a	15000	•	•	•	—
SPB	16.3 x 13	15.6	—	2400 ≤ 6000 L _d	6000	•	•	•	—
A/HA	13 x 8	9.9	—	1400 ≤ 5000 L _i	8000	•	•	•	—
				2850 ≤ 8000 L _i	on request	—	—	—	•
B/HB	17 x 11	13.0	—	1400 ≤ 7100 L _i	10000	•	•	•	—
C/HC	22 x 14	16.2	—	2286 ≤ 7100 L _i	12000	•	•	•	—

L_a = outside length; L_i = inside length; L_d = datum length

Product Range: see pages 38/39. Minimum order quantities: on request.

CONVEYOR ELEMENTS

optibelt **PKR** ENDLESS V-BELTS AND

optibelt **KB** KRAFTBANDS WITH PATTERNED TOP SURFACE



Table 91

Pattern types	Top surface height		Pitch [mm]	Groove width [mm]
	standard [mm]	maximum [mm]		
PKR 0	3	5	—	—
PKR 1	3	5	10	—
PKR 2	3	5	—	—
PKR 5	5	—	13	—

Table 92

Type/Colour	Temperature resistance [°C]	Hardness (Shore A)	Oil resistance	Loss of colour
SBR-NR/light	-40 to + 70	≈ 55*/65**	no	no
CR/black	-25 to +100	≈ 65	limited	yes

SBR = Styrene-Butadiene-Rubber

NR = Natural Rubber

CR = Chloroprene Rubber

* ≈ 55 for top surfaces above the standard height

** ≈ 65 for top surfaces within the standard height

Table 93

Profile	Stand-ard height [mm]	Standard insight length range [mm]	Pattern Type				Minimum order quantities for V-belts with patterned top surface PKR 0; PKR 1; PKR 2; PKR 5	
			PKR 0	PKR 1	PKR 2	PKR 5	for standard range (as listed on pages 30 to 33)	for non-stand-ard length ranges (sizes not included in this manual)
A/13	8.0	1 200 ≤ 5 000 ¹⁾	•	•	•	—	18 pieces	31 pieces
B/17	11.0	1 200 ≤ 2 000 ¹⁾	•	•	•	—	15 pieces	50 pieces
		2 001 ≤ 7 100 ¹⁾	•	•	•	—	15 pieces	42 pieces
20	12.5	1 850 ≤ 2 000 ²⁾	•	•	•	—	13 pieces	21 pieces
		2 001 ≤ 8 000 ²⁾	•	•	•	—	13 pieces	36 pieces
C/22	14.0	1 850 ≤ 2 000 ²⁾	•	•	•	—	12 pieces	57 pieces
		2 001 ≤ 10 000 ²⁾	•	•	•	—	12 pieces	48 pieces
25	16.0	1 850 ≤ 2 000 ²⁾	•	•	•	—	11 pieces	51 pieces
		2 001 ≤ 10 000 ²⁾	•	•	•	—	11 pieces	42 pieces
D/32	20.0	2 850 ≤ 12 500 ²⁾	•	•	•	—	9 pieces	22 pieces
		2 850 ≤ 12 500 ²⁾	—	—	—	• ³⁾	8 pieces	8 pieces
E/40	25.0	—	—	—	—	on request	on request	

1) Maximum production length on request
3) Only available in CR/black

2) Maximum production length 21,000 mm
Profile Z/10 on request

Table 94

Standard insight length range [mm]	Pattern Type		Minimum quantity
	PKR 0	PKR 2	
3 550 ≤ 10 000 ¹⁾	•	•	10
2 850 ≤ 21 000 ¹⁾	•	•	10
3 550 ≤ 21 000 ¹⁾	•	•	8
3 550 ≤ 21 000 ¹⁾	•	•	8
2 850 ≤ 21 000 ¹⁾	•	•	8
2 850 ≤ 21 000 ¹⁾	•	•	6
4 000 ≤ 21 000 ¹⁾	•	•	5

When ordering please give the overall height of the V-belt including top surface. For this purpose, you need the designation of the profile described as follows:

Profile B/17 – top surface within the standard height = 17 x 11
 Profile B/17 – with additional 3 mm top surface = 17 x 14
 Profile B/17 – with additional 5 mm top surface = 17 x 16

CONVEYOR ELEMENTS

optimat **PKR** OPEN-ENDED V-BELTS DIN 2216 WITH PATTERNED TOP SURFACE

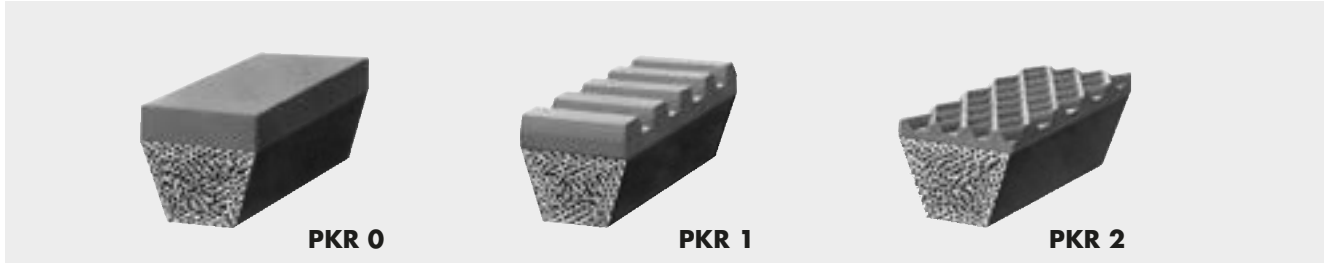

Table 95

Profile	PKR 0 CR/red-brown		PKR 0 SBR-NR/light		PKR 1		PKR 2	
	S	P	S	P	S	P	S	P
Z/10	•	•	—	—	—	—	—	—
A/13	•	•	•	•	•	•	•	•
B/17	•	•	•	•	•	•	•	•
C/22	•	•	•	•	•	•	•	•
25	•	•	•	•	•	•	•	•
D/32	•	•	•	•	•	•	—	—

S = standard; P = polyester

Table 96

Pattern types	Top surface height		Pitch [mm]
	standard [mm]	max. [mm]	
PKR 0	2	3	—
PKR 1 A/13; B/17; C/22	3	3	10
PKR 1 25; D/32	5	5	10
PKR 2	3	—	—

Table 97

Type/Colour	Temperature resistance [°C]	Hardness (Shore A)	Oil resistance	Loss of colour
PKR 0				
CR/red brown	-25 to +100	≈ 50	limited	no
SBR-NR/light	-40 to + 70	≈ 45	no	no
PKR 1 and PKR 2				
NR/red brown	-40 to + 70	≈ 48	no	no
SBR-NR/light	-40 to + 70	≈ 45	no	no
CR/red brown	-25 to +100	≈ 50	limited	no
CR/black	-25 to +100	≈ 68	limited	yes

CONVEYOR ELEMENTS

optibelt **RR** ROUND BELTS, optibelt **KK** PLASTIC BELTS

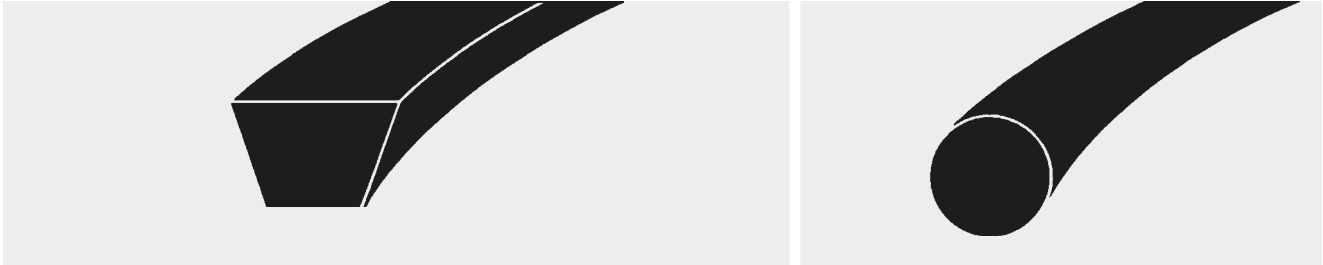

Profile	Width x Height [mm]	Roll length [m]	Diameter [mm]	Roll length [m]	Weight [≈ kg/m]
8	8 x 5	50	2	200	0.004
Z/10	10 x 6	50	3	200	0.009
A/13	13 x 8	50	4	200	0.016
B/17	17 x 11	50	5	200	0.024
C/22	22 x 14	25	6	100	0.035
			7	100	0.048
			8	100	0.064
			10	100	0.096
			12	50	0.132
			15	50	0.211

optibelt RR round belts and optibelt KK plastic V-belts are especially suitable as conveyor elements in the food industry, ceramic industry, and for applications in contact with oil and chemicals. They can also be used as drive elements for specific capacity ranges. OPTIBELT supplies different qualities that can be easily distinguished due to their different colours.

Minimum lengths for endless connection:

Round belts:	200 mm
V-belts:	Profile Z/10 to A/13: 300 mm
	Profile B/17: 500 mm
	Profile C/22: 700 mm

optibelt **KK** PLASTIC BELTS WITH PATTERNED TOP SURFACE (WHITE, 92 SHORE A) PLASTIC BELTS WITH POINTED ROOF PROFILE



Profile	Width x Height [mm]	Roll length [m]	Form	Profile	Roll length [m]
8	8 x 5	50	1	A/13	25
Z/10	10 x 6	50	2	A/13	25
A/13	13 x 8	50	1	B/17	25
B/17	17 x 11	50	2	B/17	25
C/22	22 x 14	25	1	C/22	25
			2	C/22	25

DESIGN SUPPORT

ATTACHMENTS

OVERVIEW OF STANDARDS

Federal Republic of Germany

- DIN 109 Sheet 1 – Drive Elements; Circumferential Speeds
- DIN 109 Sheet 2 – Drive Elements; Centre Distances for V-Belt Drives
- DIN 111 – Pulleys for Flat Transmission Belts; Dimensions, Nominal Torque
- DIN 111 Sheet 2 – Pulleys for Flat Transmission Belts; Classification for Electrical Machines
- DIN 2211 Sheet 1 – Grooved Pulleys for Narrow V-Belts; Dimensions, Materials
- DIN 2211 Sheet 2 – Grooved Pulleys for Narrow V-Belts; Inspections of Grooves
- DIN 2211 Sheet 3 – Grooved Pulleys for Narrow V-Belts; Classification for Electrical Machines
- DIN 2215 – Endless V-Belts, Classical Profiles; Minimum Datum Diameter of the Pulleys, Internal and Datum Belt Length
- DIN 2216 – Open-Ended V-Belts; Dimensions
- DIN 2217 Sheet 1 – V-Belt Pulleys for Classical Profiles; Dimensions, Materials
- DIN 2217 Sheet 2 – V-Belt Pulleys for Classical Profiles; Inspections of Grooves
- DIN 2218 – Endless V-Belts, Classical Profiles for Mechanical Engineering; Calculation of Drives, Performance Data
- DIN 7716 – Rubber Products; Requirements for Storage, Cleaning and Maintenance
- DIN 7719 Part 1 – Endless Wide V-Belts for Industrial Speed Changers; Belts and Groove Profiles for Corresponding Pulleys
- DIN 7719 Part 2 – Endless Wide V-Belts for Industrial Speed Changers; Measurement of Centre Distance Variations
- DIN 7721 Part 1 – Synchronous Belt Drives, Metric Pitch; Synchronous Belts
- DIN 7721 Part 2 – Synchronous Belt Drives, Metric Pitch; Tooth Space Profile of Synchronous Pulleys
- DIN 7722 – Endless Hexagonal Belts for Agricultural Machines and Groove Profiles of Corresponding Pulleys
- DIN 7753 Part 1 – Endless Narrow V-Belts for Mechanical Engineering; Dimensions
- DIN 7753 Part 2 – Endless Narrow V-Belts for Mechanical Engineering; Drive Calculation, Performance Data
- DIN 7753 Part 3 – Endless Narrow V-Belts for the Automotive Industry; Dimensions
- DIN 7753 Part 4 – Endless Narrow V-Belts for the Automotive Industry; Fatigue Testing
- DIN 7867 – V-Ribbed Belts and Pulleys
- DIN/ISO 5290 – Grooved Pulleys for Joined Narrow V-Belts; Groove Profiles: 9J; 15J; 20J; 25J
- DIN/ISO 5294 – Synchronous Belt Drives; Pulleys DIN/ISO 5296 – Synchronous Belt Drives; Belts
- DIN 22100-7 – Articles from Synthetics for Use in Underground Mines, Paragraph 5.4 V-Belts
- DIN EN 60695-11-10 – Fire Hazard Testing

ISO

– International Organisation for Standardisation

- ISO 22 – Widths of Flat Transmission Belts and Corresponding Pulleys
- ISO 63 – Flat Belt Drives; Lengths
- ISO 99 – Diameter of the Belt Pulleys for Flat Belts
- ISO 100 – Bulging Height of the Belt Pulleys for Flat Belts
- ISO 155 – Belt Pulleys; Limiting Values for Adjustment of Centre Distances
- ISO 254 – Quality, Finish and Balance of Belt Pulleys
- ISO 255 – Pulleys for Classical V-Belts and Narrow V-Belts; Geometric Testing of Grooves
- ISO 1081 – Vocabulary from V-Belts, V-Ribbed Belts and Pulleys
- ISO 1604 – Endless Speed Changer Belts and Pulleys for Mechanical Engineering
- ISO 1813 – Electrical Conductibility of V-Belts, Kraftbands, V-Ribbed Belts, Wide V-Belts, Double Profile V-Belts
- ISO 2230 – Please Consult DIN 7716
- ISO 2790 – Narrow V-Belt Drives for the Automotive Industry; Dimensions

- ISO 3410 – Endless Speed Changer Belts and Pulleys for Agricultural Machinery
- ISO 4183 – Grooved Pulleys for Classical V-Belts and Narrow V-Belts
- ISO 4184 – Classical V-Belts and Narrow V-Belts; Lengths
- ISO 5256 – Synchronous Belt Drives; Belt Tooth Pitch Code Part 1 MXL; XL; L; H; XH; XXH; Part 2 MXL; XXL Metric Dimension
- ISO 5287 – Narrow V-Belts for the Automotive Industry; Fatigue Testing
- ISO 5288 – Vocabulary from Timing Belt Drives
- ISO 5289 – Endless Double Profile V-Belts and Pulleys for Agricultural Machinery
- ISO 5290 – Grooved Pulleys for Joined Narrow V-Belts; Profiles: 9J; 15J; 20J; 25J
- ISO 5291 – Grooved Pulleys for Joined Classical V-Belts; Profiles: AJ; BJ; CJ; DJ
- ISO 5292 – Industrial V-Belt Drives; Calculations of the Performance Data and Centre Distance
- ISO 5294 – Synchronous Belt Drives; Pulleys – “Inch Pitch”
- ISO 5295 – Timing Belts; Calculations of the Performance Data and Centre Distance – “Inch Pitch”
- ISO 5296 – Synchronous Belt Drives; Belts – “Inch Pitch”
- ISO 8370-1 – Dynamic Test to Determine Pitch Zone Location with V-Belts
- ISO 8370-2 – Dynamic Test to Determine Pitch Zone Location with V-Ribbed Belts
- ISO/DIS 8419 – Belt Drives, Joined Narrow V-Belts; Lengths in Effective System; 9N/J, 15N/J, 25N/J
- ISO 9010 – Synchronous Belt Drives – Automotive Belts
- ISO 9011 – Synchronous Belt Drives – Automotive Pulleys
- ISO 9563 – Antistatic Endless Synchronous Belts; Electrical Conductibility; Characteristics and Testing Method
- ISO 9980 – Belt Drives; V-Belt Pulleys; Geometric Inspection of Grooves
- ISO 9981 – Belt Drives – Pulleys and V-Ribbed Belts for the Automotive Industry; PK Profile
- ISO 9982 – Belt Drives; Pulleys and V-Ribbed Belts for Industrial Requirements; Geometric Data PH, PJ, PK, PL and PM
- ISO 11749 – Belt Drives – V-Ribbed Belts for the Automotive Industry, Fatigue Testing
- ISO 12046 – Synchronous Belt Drives, Automotive Belts; Physical Characteristics
- ISO/CD 13050 – Synchronous Belt Drives, Curvilinear Timing Belts
- ISO/CD 17396 – Synchronous Belt Drives; Metric Pitch, Profiles T and AT

USA

- RMA/MPTA IP-20 – Classical V-Belts and Sheaves (A; B; C; D; Cross Sections)
- RMA/MPTA IP-21 – Double (Hexagonal) Belts (AA; BB; CC; DD Cross Sections)
- RMA/MPTA IP-22 – Narrow Multiple V-Belts (3V; 5V; and 8V Cross Sections)
- RMA/MPTA IP-23 – Single V-Belts (2L; 3L; 4L; and 5L Cross Sections)
- RMA/MPTA IP-24 – Synchronous Belts (MXL; XL; L; H; XH; and XXH Belt Profiles)
- RMA/MPTA IP-25 – Variable Speed V-Belts (12 Cross Sections)
- RMA/MPTA IP-26 – V-Ribbed Belts (PH; PJ; PK; PL; and PM Cross Sections)
- RMA/MPTA IP-27 – Curvilinear Toothed Synchronous Belts (8M – 14M Pitches)
- ASAE S 211. ... – V-Belt Drives for Agricultural Machines
- SAE J636b – V-Belts and Pulleys
- SAE J637 – Automotive V-Belt Drives

DATA SHEET

FOR THE CALCULATION/CHECKING OF DRIVES

OPTIBELT GmbH
 Corveyer Allee 15
 37671 Höxter
 GERMANY
T +49 (0) 5271 -621
F +49 (0) 5271 -976200
E info@optibelt.com
 www.optibelt.com

Company
(stamp)

For test <input type="checkbox"/>	New drive <input type="checkbox"/>
For initial production <input type="checkbox"/>	Existing drive <input type="checkbox"/>
For series production <input type="checkbox"/>	Usage _____ belts/year

Fitted with:

Number	Size	Manufacturer

Prime Mover

Type (e.g. electric motor, diesel engine 3 cyl.) _____

Size of starting torque (e.g. MA = 1.8 MN) _____

Method of starting (e.g. star delta) _____

Operational hours per day _____ hours

Number of starts _____ per hour per day

Rational reverses _____ per minute per hour

*Power: P normal _____ kW
 P maximum _____ kW

or maximum torque _____ Nm at n_1 _____ r.p.m.

*Speed n_1 _____ r.p.m.

Position of shafts: horizontal vertical
 angled α _____ °

Maximum allowable shaft loading $S_{a\ max}$ _____ N

*Datum or outside diameter of pulley:

d_{d1} _____ mm d_{a1} _____ mm
 $d_{d1\ min}$ _____ mm $d_{a1\ min}$ _____ mm
 $d_{d1\ max}$ _____ mm $d_{a1\ max}$ _____ mm

Pulley face width $b_{2\ max}$ _____ mm

Driven Machine

Type (e.g. lathe, compressor) _____

Start: loaded unloaded

Nature of load: constant pulsating
 shock

Rating: P normal _____ kW
 P maximum _____ kW

or maximum torque _____ Nm at n_2 _____ r.p.m.

Speed n_2 _____ r.p.m.
 $n_{2\ min}$ _____ r.p.m.
 $n_{2\ max}$ _____ r.p.m.

Maximum allowable shaft loading $S_{a\ max}$ _____ N

Datum or outside diameter of pulley:

d_{d2} _____ mm d_{a2} _____ mm
 $d_{d2\ min}$ _____ mm $d_{a2\ min}$ _____ mm
 $d_{d2\ max}$ _____ mm $d_{a2\ max}$ _____ mm

Pulley face width $b_{2\ max}$ _____ mm

Speed ratio i _____

•Centre distance a _____ mm

Tension/guide pulleys: inside
 outside

d_d _____ mm V-pulley
 d_a _____ mm flat pulley

i_{min} _____ i_{max} _____

a_{min} _____ mm a_{max} _____ mm

in drive slack side
 in drive tight side

movable (e.g. spring loaded) _____
 fixed

Operating Conditions: Ambient temperature

_____ °C minimum
 _____ °C maximum

Exposure to oil
 water
 acid
 dust

* required
 • optional

(e.g. oil mist, droplets) _____
 (e.g. spray) _____
 (type, concentration, temperature) _____
 (type) _____

Special conditions: Where the drive is subjected to unusual conditions, e.g. inside or outside idler pulleys, 3- or multi-pulley drives, as well as drives with reverse rotational direction, drawings are required. Please use the back of this data sheet for sketches.

Details about the drive:

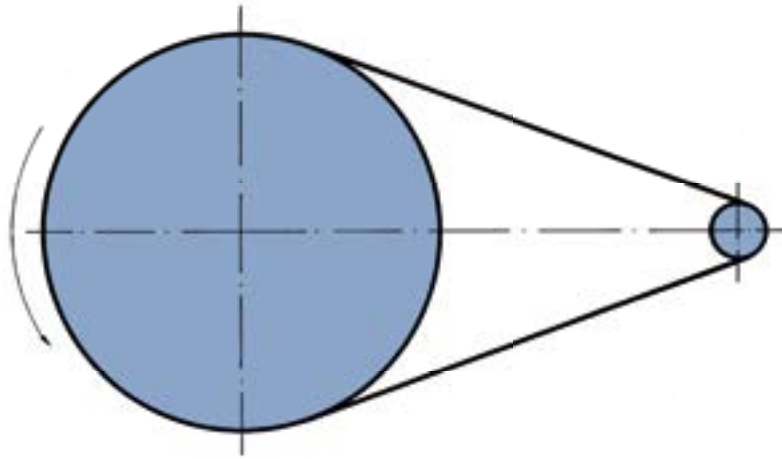

Details about the conveyor system:

Owner of any and all copyrights and intellectual property rights as well as other rights of use and exploitation:
Arntz OPTIBELT Group, Höxter/Germany. Any use, exploitation, reproduction, and any transfer to third parties by any means shall require the prior written approval of the Arntz OPTIBELT Group, Höxter/Germany.

Print: 414773/0313Hux

OPTIBELT GmbH

Corveyer Allee 15
37671 Hörter
GERMANY

T +49 (0) 5271-621
F +49 (0) 5271-976200
E info@optibelt.com



www.optibelt.com