

# DAIKIN OIL COOLING UNIT INSTRUCTION MANUAL

HP	MODEL NAME
1	AKS100T-D46-C
	AKS100T-D33-C

THANK YOU FOR PURCHASED  
DAIKIN OIL COOLING UNIT.

Before you use the unit, please be sure to read this instruction manual for knowing how to use it correctly.

☉It will also help when, with the machine in use, you have any questions or have experienced trouble of any kind about it.

☉After persuading, please keep this with the spares.

This instruction manual has contained in everything you should know when you use the OIL COOLING UNIT.

## CONTENTS

1. Cautions in general .....	1
2. Cautions for installation .....	2
3. Electrical wiring .....	3
4. Cautions for operation .....	6
5. Names, functions and .....	7
operation on control panel	
6. Alarm functions .....	17
7. Installation of each .....	22
thermistor	
8. Maintenance and inspection .....	23
9. Troubleshooting guide .....	24

# 1 CAUTION IN GENERAL

## 1-1 Operating range

Since oil cooling unit is a refrigeration machine, the operative room and temperatures are limited.

Use oil cooling unit in the ranges shown below.

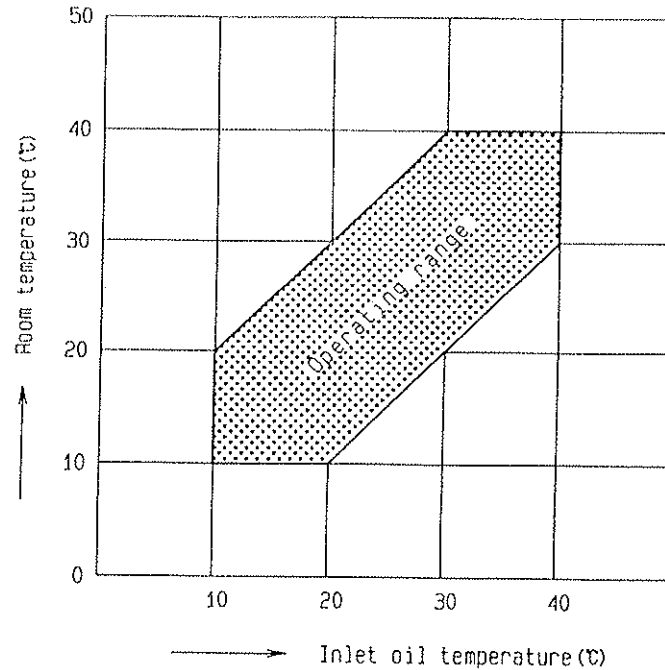

## 1-2 Acceptable oils

Hydraulic fluids(of mineral oil origin)and lubricating oil shall be used for this unit. therefore, the following oil(fluid)shall not be used for this unit.

- 1)Fire-resistant hydraulic oil(hydraulic oils of phosphoric ester, chlorinated hydrocarbon oils, water/glycol hydraulic oils and W/O and O/W emulsion type hydraulic oils).
- 2)Water and water soluble liquids.
- 3)Liquid chemicals and foods.
- 4)Cutting oils(fluid)and grinding oils(fluid).
- 5)Fuel such as kerosene, gasoline, etc.

# 2 CAUTION FOR INSTALLATION

## 2-1 Installation location

- Install in the following location.
  - 1) On a solid and flat floor.
  - 2) Away from direct sunlight and heat.
  - 3) Where there is good ventilation and little humidity.
  - 4) Where the discharged gas will not be drawn in again.
  - 5) A place convenient for piping and wiring.
  - 6) Where there is little dust, dirt, powder, oil mist, etc.
- Do not place anything in the way of ventilation with in 500mm distance from intake and exhaust area.

## 2-2 oil piping

- 1)•Suction(Oil inlet)side.....-230~0mmHg(Vacuum pressure)
  - Discharge(Oil outlet)side...3kgf/cm<sup>2</sup> or less.
- 2)Do not use more valves then necessary in the piping valves, even if fully open, cause a considerable loss in pressure.
- 3)Use sealing tape around pipe connections to prevent air infiltration and oil leakage.

## 2-3 How to change exhaust direction

- Exhaust direction of the oil cooling unit can be change(right or left side).
  - 1)Remove the exhaust cover.
  - 2)Fix the exhaust cover to opposite side.

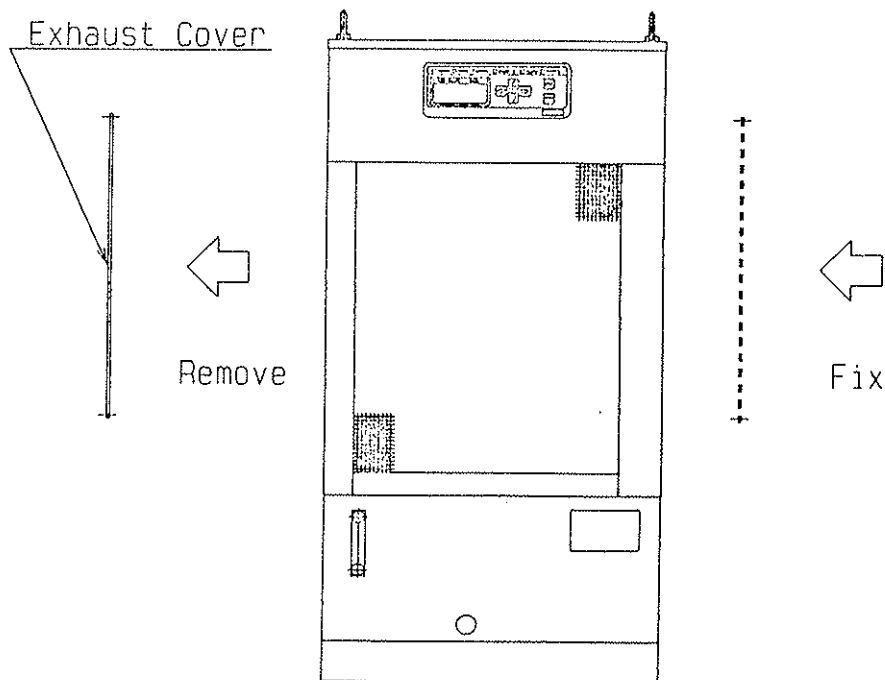

### 3 ELECTRICAL WIRING

- For electric wiring work, refer to the electric wiring plate attached to the back side of switch box cover.
- Do not change the wirings nor operate the electromagnetic switches manually inside the OIL COOLING UNIT.

#### 3-1 Power source capacity

Rated voltage	Power source capacity(KVA)	
	AKS100T-D46-C	AKS100T-D33-C
Three phase, 200Volts	2.5	2.9
Three phase, 220Volts	2.8	3.2

#### 3-2 Grounding and power source connection

- 1) Remove the front panel and roof.
- 2) Pass the main power wires and ground wire (600V PVC insulated power wire, 2mm<sup>2</sup> or more) through the power wiring supply hole ( $\phi 27\text{mm}$ ) in the left or right side and into the switch box.
- 3) Connect the ground wire to the terminal block (TB1).
- 4) Connect main power source wires L1, L2 and L3 to the corresponding L1, L2 and L3 on the terminal strip (TB1).
- 5) When the power source is connected to the reverse phase, change the two wires, L1 and L2, as shown in the Fig. below.  
(If in reverse phase, an alarm display is indicated "U1" on the control panel by the individual abnormal function.)

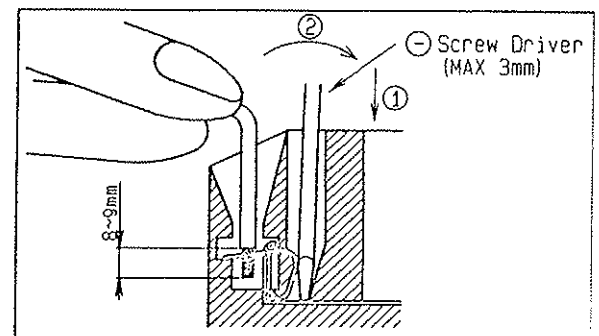
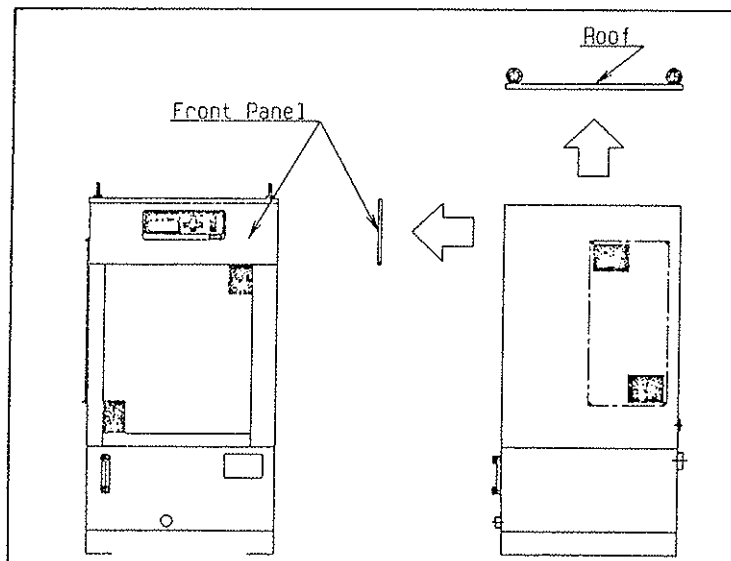

3-3 Remote control and connecting the alarm contact  
 1) Wire as indicated below for remote control.

Part to be prepared.

Part		Wiring material
Single-pole, single-throw remote control switch or "a" contact capable of transmitting control signal.		HVSF0.75mm <sup>2</sup> wire
Minimum contact capacity.	AKS100T-D46-C 10mA(DC24V) AKS100T-D33-C	

2) Remove the short-circuit wire (terminal Nos. (10)-(11)) from the terminal strip inside the switch box.

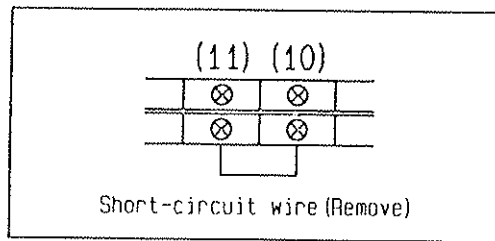

3) Connect Nos. (10)-(11) on the terminal strip with the remote control operation.

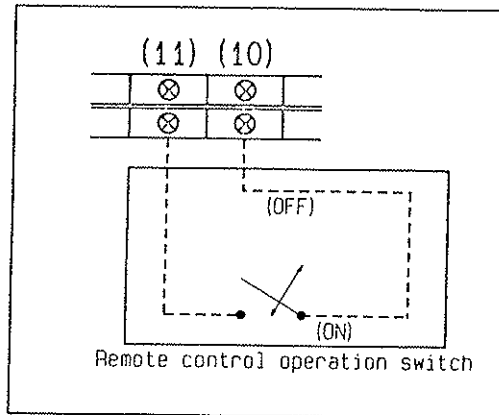

4) Outside output connection of alarm (Nos. 60, 61, 62, 63, 64, 65) are as shown in the figure below. Please use connecting terminals on necessary.

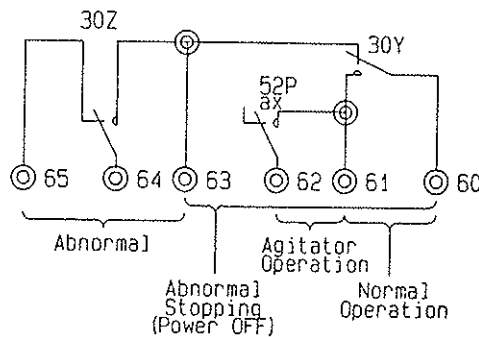

## 4 CAUTIONS FOR OPERATION

4-1 NEVER RUN WITHOUT OIL IN THE MACHINE. (This causes damage to the oil pump, etc.)

4-2 Prevent air from being mixed into the oil piping system.  
(If air is mixed in, it causes noise)

4-3 Since the delay timer is installed, the OIL COOLING UNIT will not start again immediately after it was stopped in order to protect the compressor from being overloaded.  
This is normal and does not indicate any problem with the OIL COOLING UNIT.

# 5 NAMES, FUNCTION AND OPERATIONS ON CONTROL PANEL

## 5-1 Outline of control panel

### 1) Outline

The following describes the functions and operating method of the display panel. Detail are further explained in the section of each panel item.

### 2) External diagram

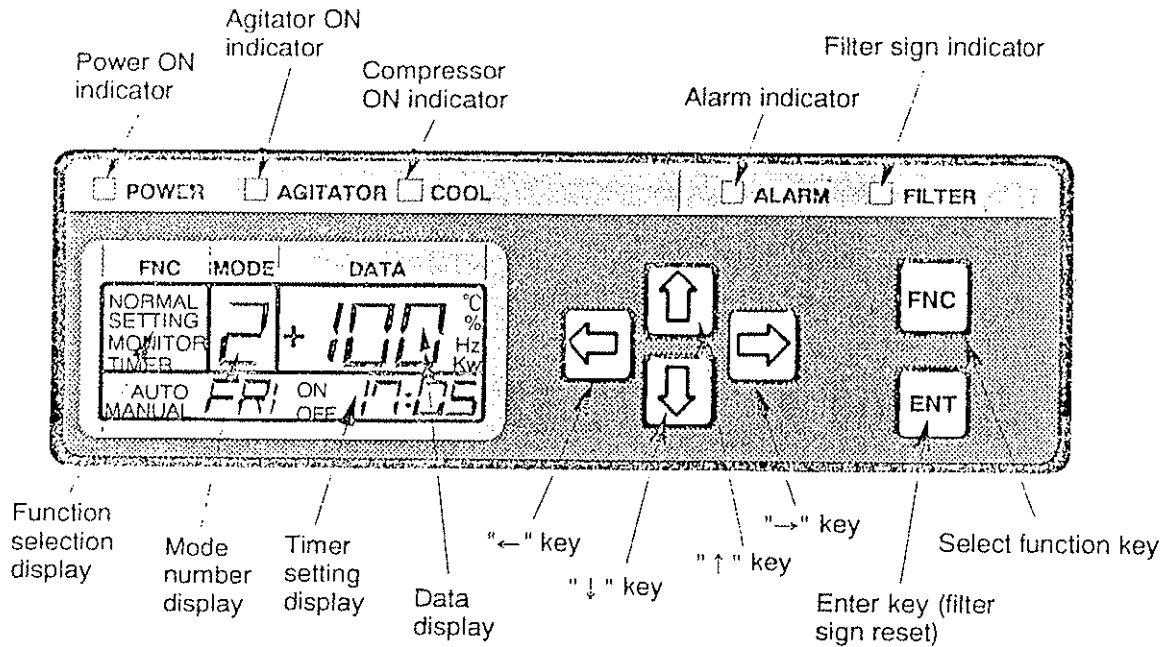

### 3) LED indicator section

Item	Description
Power ON indicator (green)	Turns ON When the +5V power is supplied to the controller Even when this indicator is OFF, the main power may be supplied to the equipment.
Agitator ON indicator (green)	Turns ON when the agitator is in operation (when protection input 52Ka is ON).
Compressor ON indicator (green)	Turns ON when the compressor is in operation.
Alarm indicator (yellow)	Turns ON when the controller detects an abnormality. When a level-1 alarm is generated, the indicator flashes in 0.5-second intervals.
Filter sign indicator (yellow)	Turns ON when the duration of the power supply to the oil cooling unit exceeds the predetermined time (parameter setting).

## 4) LCD display section

Item	Description
Function selection display	indicates the current operation mode.
Mode number display	indicates the current temperature-controlled operation mode.
Data display	indicates the target value of the temperature control. (The displayed information varies depending on the temperature-controlled operation mode.)
Timer setting display	indicates ON/OFF of the timer operation and the setting of the ON/OFF time.

## 5) Keys

Item	Description
"FUNC" key (function setting key)	Used to change operation modes. Pressing this key during data entry cancels the input, and changes to the next operation mode.
"ENT" Key (input entry key)	Used to enter input data. (Also functions as filter reset key)
"↑" "↓" Key	Used to change display value. (Generally "↓" indicates reduction, while "↑" indicates increase.)
"→" "←" Key	Used to select the item and digit of data input.



There are six operation modes, as shown below.

Operation mode	Function selection display section	Description	Accessibiliy
Operation lock	LOCK flashes	Prohibits all key operations except lock cancellation, and operation of the agitator motor and fan motor(factory setting). The data display section shows flashing "Lock" indication.	User
Normal	NOMAL illuminates	Display the target operation value. (Main operation mode)	
Data setting	SETTING illuminates	For operation data setting.	
Monitor value display	MONITOR illuminates	Display data such as sensor temperatures.	
Timer setting	TIMER illuminates	For the ON/OFF time setting of timer operation.	
Parameter setting	SETTING flashes	For setting the parameter that determine the operation characteristic of the oil cooling unit.	Equipment manufacturer

The "normal", "data setting", "monitor value setting" and "timer setting" modes are commonly used by the user, and the mode changes in a set order every time the FUNC key is pressed.

A special procedure must be followed to change to other modes.

The key operation and operation mode changing order are shown in the diagram on the next page.

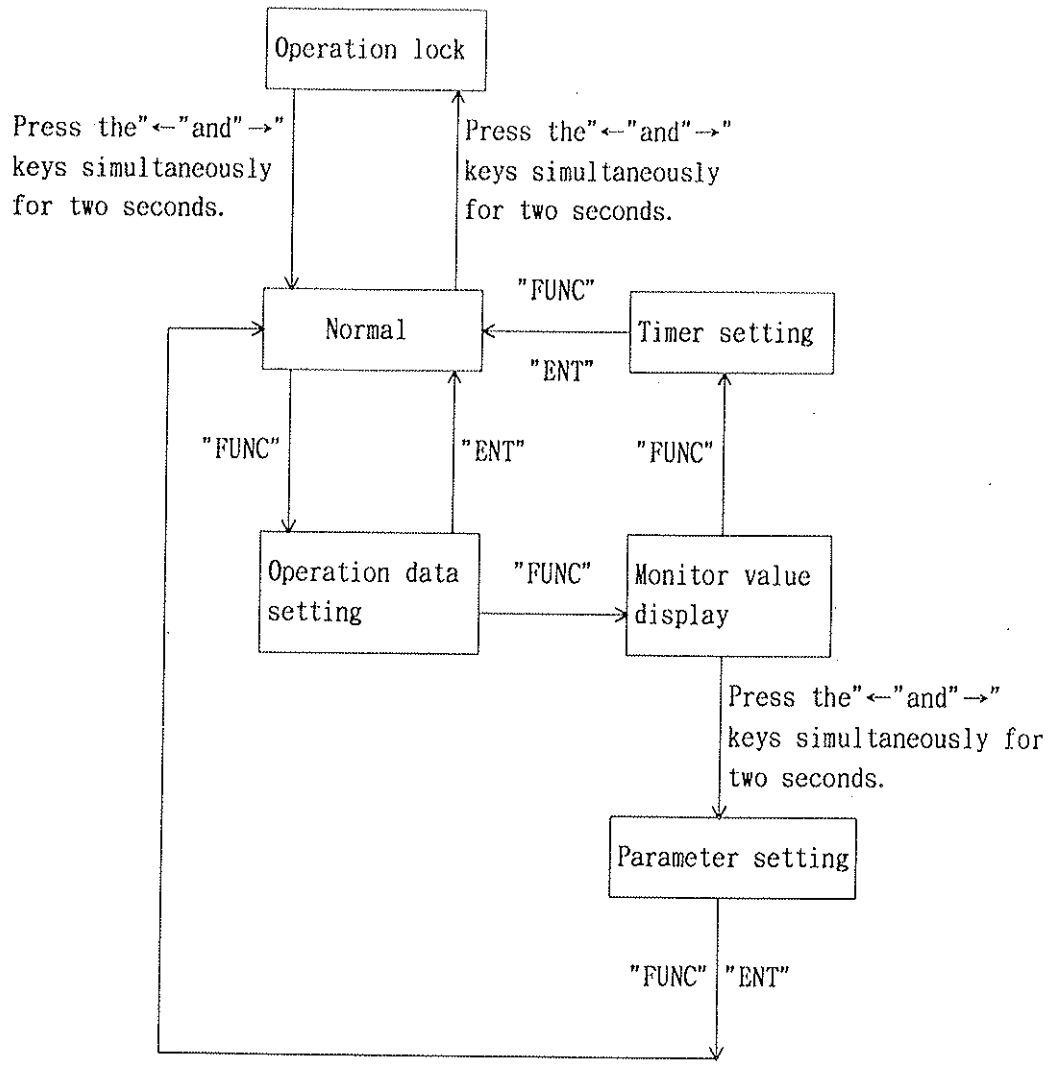

## 1) Outline

This mode display the operation mode and target control value of the oil cooling unit.

## 2) Indication

## 1. When alarm is not generated

The operation mode is indicated on the mode display section, and the target control value is shown on the data display section.

When the target control temperature value obtained from the synchronous liquid temperature control exceeds the allowed temperature setting range, a limiter is automatically set on the target control value, and the result is displayed.

Mode display section		Data display section		
Mode No.	Mode	Displayed information	Displayed value	Unit
0	Fixed liquid temperature control	Liquid temperature	5.0~50.0	°C
2	Fixed equipment temperature control	Equipment temperature		
3	Synchronous liquid and atmospheric temperature control	Liquid temperature		
4	Synchronous liquid and equipment temperature control			
8	Synchronous liquid and equipment temperature control	Equipment temperature		
9	Direct compressor operating instruction	0:OFF, 1~:ON		

## 2. When alarm is generated

The operation mode is indicated on the mode display section, and the alarm code is shown on the data display section.

Mode display section	Data display section		
Mode	Displayed information	Displayed value	Unit
Current operation mode	alarm code(See the alarm code table.)	Rightmost digit:OFF second and third Digits from the right: alarm code(flashes)	OFF

## 3) Operating method

## 1. Filter sign reset

The filter sign indicator turns ON when the duration of the power supply to oil cooling unit exceeds the predetermined time(parameter setting).

This indication can be turned OFF by pressing the ENT key.

## 2. Operation lock

The operation lock can be activated by simultaneously pressing the "←" and "→" keys in normal operation mode for two seconds.

When the operation lock is engaged, the data display section shows a flashing "Lock" indication, and the MANUAL and AUTO indications on the timer setting display section turn OFF.

The operation lock mode cannot be canceled by turning off the power and turning it back on.

The operation lock can be canceled by simultaneously pressing the "←" and "→" keys for two seconds. When the operation lock is canceled, the equipment returns to normal operation mode. After this operation, be sure to set the timer setting to MANUAL.

Transporting the equipment in operation lock mode prevents accidents resulting from turning on the main power and before pipe connection check is completed after installation.

## 3. Adjusting the day and time

Conducting the following table process in normal operation mode advances the display of the day of the week, hours and minutes.

There is no carry to hours from minutes or to week from hours.

Day of the week	Press the "↓" and "←" keys simultaneously.
Hours	Press the "↓" and "↑" keys simultaneously.
Minutes	Press the "↓" and "→" keys simultaneously.

## 4) Note

## 1. Operation mode

Depending on the oil cooling unit device, not all operation models can used.

5-4 Operation data setting mode

1) Outline

This mode is used to change the operation mode and setting of the oil cooling unit.

2) Operation mode setting range

The following table shows the operation modes and data setting range.

Mode No.	Mode	Setting range	Unit
0	Fixed liquid temperature control	5.0~50.0	°C
2	Fixed equipment temperature control		
3	Synchronous liquid and atmospheric temperature control	-9.9~9.9	K
4	Synchronous liquid and equipment temperature control		
8	Synchronous equipment and atmospheric temperature control		
9	Direct compressor operation instruction	0~100	%

1. Fixed liquid temperature control(modes 0 and 2)

Controls the temperature of the control item to the set level.

2. Synchronous liquid temperature control(modes 3, 4 and 8)

Controls the temperature of the control item to the temperature value calculated with the following equation.

Target control temperature = Synchronizing source temperature + set value (offset value)

If the result of the calculation is lower than 5.0°C, the target control temperature is set to 5.0°C, while if the result is over 50.0°C, it is set to 50.0°C.

3. Direct compressor control(mode 9)

Direct controls the compressor without temperature control.

The 0% setting turns off the compressor, and a setting of > 0% turns on the compressor.

### 3) Operating method

#### 1. Changing the operation mode

When this mode is selected, the current operation mode indication on the mode number display section flashes.

Use the "↑" and "↓" keys to select the desired operation mode number.

(The data display section indicates the setting data for the selected operation mode.)

#### 2. Changing the setting data

When the "→" key is pressed while the operation mode display is flashing, the data display flashes.

Use the "↑" and "↓" keys to change the indication to the desired value.

(One key operation increases or decreases the displayed value by 0.1°C(1%).)

If the repeat key function is activated, however, the value increases or decreases by 1.0°C(10%).)

If the set data exceeds the range allowed for the selected operation mode, the lower-limit value(or upper-limit value) is set.

#### 3. Entering and canceling the data

Pressing the ENT key enters the input value. The buzzer turns on for one second, and the input value lights at the same time. Then the equipment return to normal operation mode.

Pressing the FUNC key during data input cancels the operation mode and setting data being input.

Pressing the "←" key during data input cancels the input data, and returns to the operation mode selection mode.

### 4) Note

#### 1. Operation mode

The data display section shows "---" when an unused operation mode is selected, and data setting is not possible.

## 5-5 Monitor value display mode

## 1) Outline

This mode is used to display data such as sensor temperatures.

## 2) Display data and ranges

The following table shows the monitor value corresponding to the item number.

Mode No.	Mode	Display range	Unit	Remarks
0	Equipment temperature	-99.9~99.9 Note 1)	°C	
1	Not used			
2	Air temperature			
3	Liquid temperature			
4	Not used			
5	Power supply frequency	0~127	Hz	
6	Direct compressor control instruction value	0~100	%	
7	Not used	Displays "----"	OFF	
8				
9				

Note 1) The detectable temperature range of the oil cooling unit is between -40°C and +180°C. If the sensor is short-circuited, the display indicates "-99.9°C".

## 3) Operating method

## 1. Confirming the monitor value

When this mode is selected, "0" flashes on the mode number display section.

Use the "↑" and "↓" keys to select the desired item number.

(The data display section indicates the monitor data corresponding to the selected operation mode.)

5 - 6 Time setting mode

1)Outline

This mode is used to change the timer settings. There are MANUAL and AUTO timer modes, and they are defined as follows.

Timer mode	Description
MANUAL	Timer not used
AUTO	Timer used

The timer allows one ON and one OFF settings for each day of the week from Sunday to Saturday.

The time scale of 00:00 to 23:59 is commonly used. However, since work may continue past 23:59 of the setting day into the following day, timer setting is possible between 00:00 to 29:59(5:59 of the following morning).

2)Operating method

1. Selecting the timer mode

When this mode is selected, the current timer mode flashes. Use the "↑" and "↓" keys to select the desired timer mode.

2. Selecting the timer setting

When the "→" key is pressed in the timer mode selection mode, the timer setting day of the week flashes. "MON" is displayed when the timer mode is selected. Use the "↑" and "↓" key to select the display day of the week and either ON or OFF. Use the "←" key to return to the timer mode selection mode.

3. Setting the hour

Use the "↑" and "↓" keys to set the minute for the selected timer setting item(day of the week, ON/OFF). The setting range is between 00 and 29. Use the "←" key to return to the timer setting selection mode.

4. Setting the minute

Use the "↑" and "↓" keys to set the minute for the selected timer setting item(day of the week, ON/OFF). The setting range is between 00 and 59. Use the "←" key to return to the timer hour selection mode.

5. Entering and canceling the data

Pressing the ENT key enters all the timer settings. The buzzer turns on for one second, and the set value lights at the same. Then the equipment returns to normal operation mode.

Pressing the FUNC key during setting operation cancels all the settings, and returns to normal operation mode.



## 1) Filter sign time setting range

Mode No.	Mode	Display range	Unit	Remarks
0	Filter sign time setting	1~9	OFF	(100hours)

## 2) Operating method

## 1. changing the item No.

When this mode is selected, "0" flashes on the mode number display section.

Use the "↑" and "↓" key to select the desired item number.

(The data display section indicates the setting data corresponding to the selected item number.)

## 2. Changing the setting data

Press the "→" key when the item number for which the setting is to be changed is flashing. The data display starts flashing.

Use the "↑" and "↓" keys to change the data to the desired value.

If the set data exceeds the allowable range, the lower-limit value (or upper-limit value) is set.

## 3. Entering and canceling the data

Pressing the ENT key enters the input data. The buzzer turns on for one second, and the input value lights at the same time. Then the equipment returns to normal operation mode.

Pressing the FUNC key during data input cancels the operation mode and the setting data being input.

Pressing the "←" key during data input cancels the input data, and returns to the item number selection mode.

# 6 ALARMS

## 6-1 Outline of alarm processing

### 1) Outline

The oil cooling unit(AKS, AKJ)sends the cool operating oil the heat-generating section of the main equipment using the hydraulic pump in order to maintain the main equipment temperature at a constant level.

Therefore, even if an abnormality is detected, it is important that the hydraulic pump continues operation. (If the circulation of the operating oil stops, the moving parts of the main equipment can seize due to overheating.)

To enable continuous pump operation, the alarms are classified into two levels, Level 1 and 2. Level 2 allows pump operation, while Level 1 stops pump operation.

## 6-2 Alarm level and priority

A Level-1 alarm is considered a high-level alarm, while a Level-2 alarm is a low-level alarm.

The following describes the levels of alarms and processing methods.

(Note) Abnormality A refers to the first abnormality detected, and abnormality B refers to the second abnormality.

### 1) When a single abnormality is detected

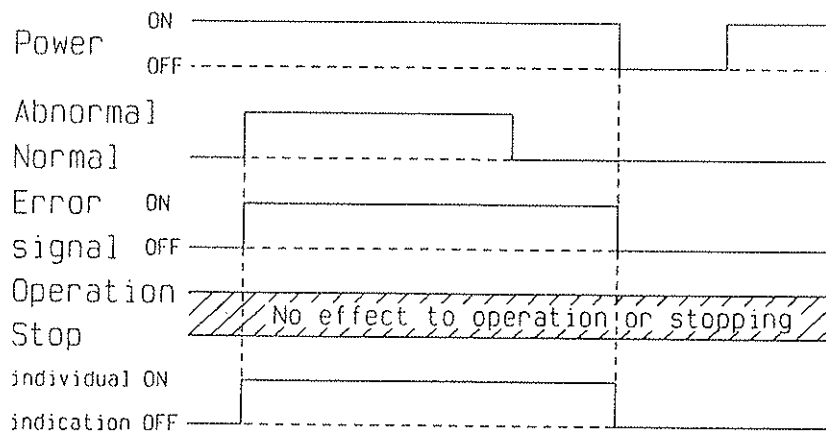

### 2) When multiple abnormalities are detected

#### 1. When abnormalities A and B are of the same alarm level.

The detection of abnormality B is ignored, and the alarm of abnormality A continues to be used.

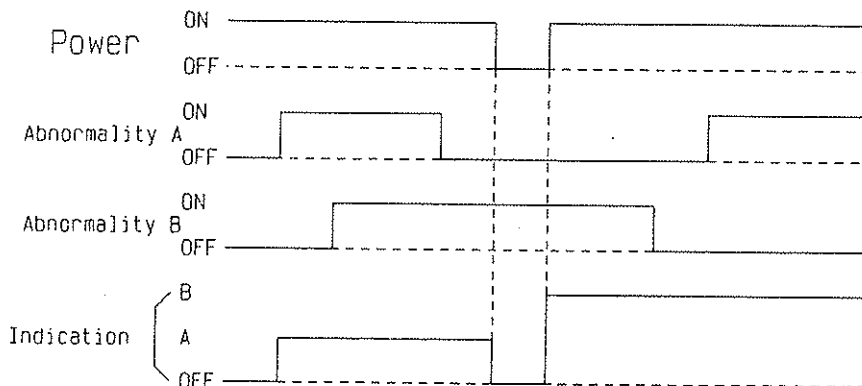

2. When the alarm level of abnormality A is higher than the alarm level of abnormality B. The detection of abnormality B is ignored, and the alarm of abnormality A continues to be used.

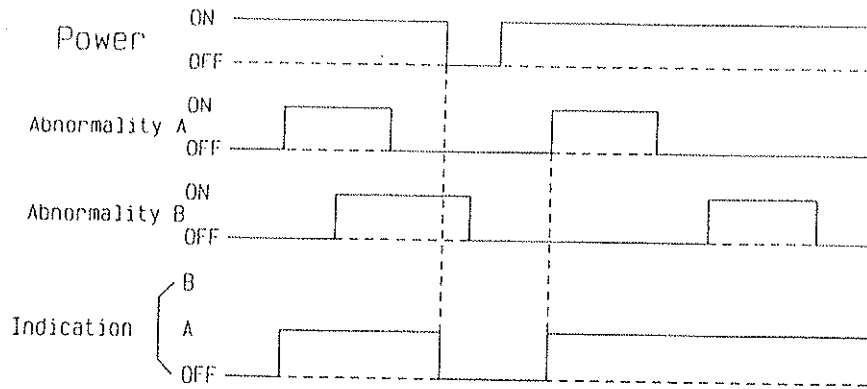

3. When the alarm level of abnormality B is higher than the alarm level of abnormality A. The alarm of abnormality A is used at the time of the detection of abnormality A. However, as soon as abnormality B is detected, and the alarm switches switches to that of abnormality B.

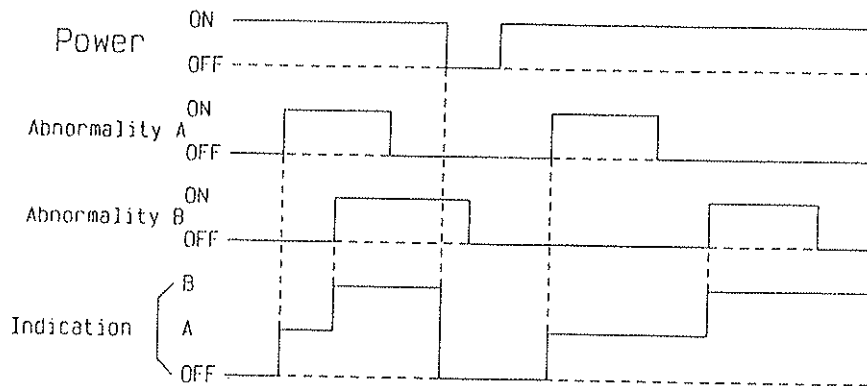

## 6-3 Processing alarm generation

## 1) Alarm indication on the control panel

The data display section of the control panel shows the alarm code of the result of the alarm processing based on the alarm level priority.

(only when the operation mode of the display panel is set to NORMAL or TIMER)

The alarm indicator on the control panel lights or flickers as shown below.

Item	Alarm indicator
Level-1 abnormality	Flickers at 0.5-second intervals
Level-2 abnormality	ON

The buzzer also turns on.

## 2) Abnormality record in memory

When an alarm is generated, the current values of the data in the following table are written in the error parameter memory area in the EEPROM.

Mode No.	Mode
0	Alarm code
1	Power supply frequency
2	Not used
3	Equipment temperature
4	Not used
5	Atmospheric temperature
6	Liquid temperature
7	Not used
8	Cumulative compressor operating hours

The data of the first abnormality that occurs after the power is turned on is written into the memory. When multiple errors are generated and alarm switching occurs according to the priority-based processing (described in 6-2), the newer error data is written.

3) Clearing the alarm

The alarm can be cleared by turning off the power and turning it back on.

Motor overcurrent error E6, however, must be reset in the service monitor mode.

(Error E6 cannot be cleared by turning the power off.) When error E6 is generated, please contact Daikin service center.

(Please note the following exception: If an abnormality of Level 1 is generated after the generation of error E6 and before its clearing operation, E6 (Level-2 abnormality) is overwritten. This cancels the error E condition, allowing the equipment to restart by turning the power off and back on again.

4) External alarm output

1. External alarm communication output port

The alarm output [DOUT\_ALARM] of the external parallel communication output port turns ON.

2. Relay contact output

When an alarm is generated, output 30Y turns OFF, and output 30Z turns ON.

The following diagrams show the relay contact output conditions.

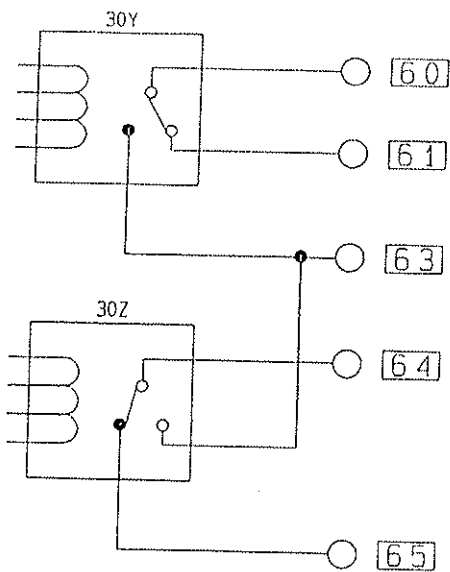

No alarm generated (normal)

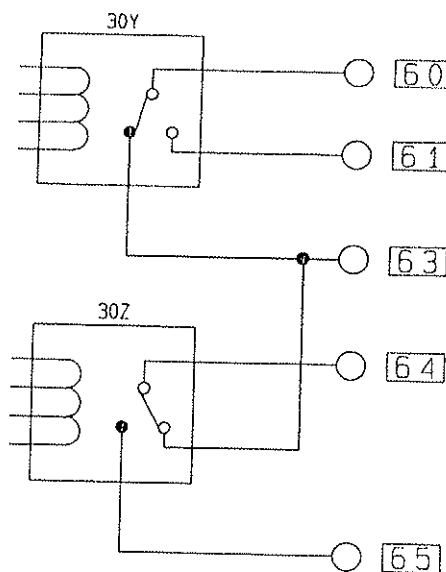

When alarm generated

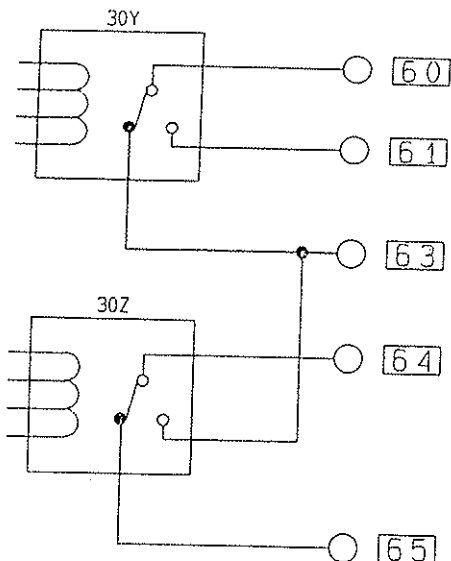

In power outage, or in case of faulty CPU startup

## 6-4 Alarm codes and levels

The following table shows the definition of alarm codes of errors detected by the temperature control PCB.

Alarm code	Level	Communication code	Internal definition	Description of error
E1	2	049	ALARM_BOARD	Faulty PCB Illegal overload
E3	2	051	ALARM_63H	63H(high pressure switch)activation
E5	2	053	ALARM_49C	49C(compressor head thermal bimetal) activation
E6	2	054	ALARM_51C_CT	51C(compressor overcurrent relay)activation, or overcurrent detected by CT(Contact Daikin service center.)
EH	1	059	ALARM_51P	51Ka(agitator overcurrent relay)activation
H1	2	065	ALARM_SEN_AIR	Faulty Th1 or Th3(short-circuit, broken wire)
H6	2	070	ALARM_SEN_CT	Faulty current detection by CT
HH	1	075	ALARM_52PA	Faulty 52Ka(agitator magnet)operation
FH	1	091	ALARM_OIL_HI	Abnormally high oil temperature
FE	1	094	ALARM_FLSW	Disconnection of CN23 connector
JH	2	107	ALARM_SEN_OIL	Faulty Th4(short-circuit, broken wire)
P1	1	129	ALARM_POW_LOSS	Open phase
U1	1	145	ALARM_POW_REV	Power reverse phase, power frequency abnormality, overvoltage
U6	1	150	ALARM_DISP_COMMU	Faulty communication between temperature controller and display CPU
UH	1	155	ALARM_SYSTEM	System error(EEPROM error)

## 6-5 Alarm codes of control panel

The following table shows the definition of alarm code of errors detected by the CPU of the display.

When the following alarm is generated. (the alarm code "E1" is generated by the temperature control PCB.)

Alarm code	Name of alarm	Description
E-01	Power shut-off detection port error	The power shut-off detection port is remaining Lo.
E-02	Key input port error	The key input port is remaining Lo.
E-03	LED output error	The LED output port is remaining Lo.
E-04	Buzzer/LEDA output port error	The buzzer/LEDA output port is remaining Lo.
E-05	RTC access error	RTC cannot be accessed.
E-06	RTC memory data error	RTC can be accessed, but the data in memory causes a check-sum error.

Note 1) Since errors E-01 to E-05 are due to faulty hardware, resetting the equipment does not cancel these errors.

Note 2) As soon as error E-06 is generated, the data is initialized. Therefore, resetting the equipment cancels the error.

# 7 MAINTENANCE AND INSPECTION

## 7-1 Repair work with safety

In conducting the maintenance and inspection work, be sure to put the operation switch in OFF position to turn OFF the main power supply.

(It is extremely dangerous to conduct the work since there is a possibility of electrification or coming in contact with rotating objects if the equipment remains operated.)

## 7-2 Casing

- 1) Polish the casing surface with dry cloth. If the surface is heavily fouled, remove the dirt with high quality soap or neutral detergent. Never pour water direct to the equipment. (Operation of as-wetted equipment may lead to electrical leakage or fire.)
- 2) To prevent coatings from peeling off, do not use brushes, polishing powder, acids, solvents such as benzine etc, hot water, and so on.

## 7-3 Tank and return filter (by local arrangement)

- 1) Maintain the liquid level in the tank in normal position to prevent the liquid leakage caused by liquid. Note that the liquid should be controlled so as to be kept clean at all times.
- 2) Clean up periodically the return filter for use on the return (liquid inlet) side of tank to prevent such reduction of liquid volume in the tank as is caused by clogging of dirt.

## 7-4 Air filter

- 1) Be sure to wash the air filter once every 2 weeks with neutral detergent. If dirt or dust is accumulated on the air filter, the filtering capacity is lowered by reduction in air flow and, at the same time, the protective device of compressor will operate to prevent a smooth operation.
- 2) If the equipment is put into operation without the air filter, the resultant loss of dust removal effect will result in fouling of the equipment (especially, condenser), thus leading to a cause of trouble.
- 3) When the condenser is heavily fouled, clean it up with brush, air gun, etc.

## 7-5 Case of long-time shutdown

- 1) Use care to prevent dirt, dust, water, etc. From coming into the OIL COOLIG UNIT.
- 2) Be sure to put the operation switch in OFF position to turn OFF the main power supply.
- 3) Take precautions so that no oily dirt and dust will deposit on the condenser surface of refrigerator.



# 8 TROUBLESHOOTING GUIDE

Check the following if the OIL COOLING UNIT does not function properly.

If the OIL COOLING UNIT still does not function properly, contact our office and give the following particulars: (1) model, (2) manufacturing No. [(1) and (2) are on the machine nameplate], (3) condition of the machine. (as much detail as possible.)

Item	Condition	Cause	Remedy
1	Power is ON but power indicator lamp (white) does not light up.	① Power indicator lamp does not light up.	• Replace indicator board (EC2)
		② Control circuit fuse is blown.	• Replace fuse. • Check and repair the short-circuit points in the operation circuit.
		③ Control circuit breaker is OFF. { model with main power over-current circuit breaker }	• Turn the circuit breaker ON. Check and repair the short-circuit points in the operation circuit.
2	Power is ON but an abnormality lamp (red) flickers.  (1) Protective device against reverse phase actuated.	① Power source is connected to reverse phase.	• Re-connect 2 phases out of 3
3	Pump runs but no oil flow. Low oil circulation, with air suction and loud pump noise.	① Oil piping on suction side is loose.	• Check if the suction piping is tight. Tighten if not tight.
		② Suction strainer is clogged.	• Clean the suction strainer. • Change the oil in the oil tank if it is dirty.
		③ Tank oil level is too low.	• Eliminate the cause of the drop in oil level and add oil.
		④ Excessive pressure loss in the oil piping causes relief valve actuation and pump cavitation.	• Use larger diameter pipe and shorten the piping.

Item	Condition	Cause	Remedy
4	Pump runs but compressor does not.	①Thermostat functions properly and stops the compressor.	•Set the thermostat to the low temperature side and check if the compressor starts. The compressor won't start if oil temperature is too low. Wait until oil temperature rises.
		②Thermostat(delay timer 105±15 sec. setting)is activated.	•Reset the timer and check if the compressor starts.
		③Thermostat is damaged.	•Replace thermostat.
5	Compressor worked but the pump and compressor stopped without the power and abnormality display lamp lighting up.	①Power is off	•Check the main power source.
6	Compressor worked but an abnormality signal was output and abnormality display lamp lit up.	○Do make the countermeasure after confirmation of cause by display lamp.	
	(1)An abnormality took place at the thermistor	①The thermistor is broken. Wiring of the thermistor is shortcircuited or dislocated.	•The thermistor must be replaced. Carry out wiring connections correctly.
	(2)Protective thermostat for high oil temp. is actuated.	②Oil temperature is abnormally high	•Suspend operation until oil temperature goes down.

Item	Condition	Cause	Remedy
6	(3) Compressor protection thermostat(49C) is actuated. (4) Compressor motor overcurrent relay (51C) is actuated. (5) High pressure switch(63H) is actuated. (6) Pump motor overcurrent relay (51P) is actuated. (7) Agitator motor overcurrent relay (51K) is actuated.  (8) An abnormality took place at the control circuit board(EC1).	③ The air filter is clogged. ④ There are obstacles near the suction/exhaust ports. ⑤ Ambient(room) temperature is too high.  ⑥ Oil temperature is too high ⑦ Compressor does not run.  ⑧ Oil viscosity is too high  ⑨ Same as 3-④  ⑩ Agitator motor does not run.  ⑪ The control circuit board is out of order.	<ul style="list-style-type: none"> <li>• Clean the air filter.</li> <li>• Remove the obstacles.</li> <li>• Use the unit within its operation range. If there is a heat source, remove it.</li> <li>• Use at low temperature.</li> <li>• Compressor must be replaced (service).</li> <li>• Replace with lower viscosity oil.</li> <li>• Same as 3-④</li> <li>• Agitator motor must be replaced(service).</li> <li>• The control circuit board must be replaced.</li> </ul>
7	Pump, compressor and fan run but oil is not cooled.	① Same as 6-④ to ⑦  ② Same as 3.  ③ Over-loading.  ④ Setting of thermostat too high.  ⑤ Lack of refrigerant gas.	<ul style="list-style-type: none"> <li>• Same as 6-④ to ⑦</li> <li>• Same as 3.</li> <li>• Eliminate the cause of overloading.</li> <li>• Set it properly.</li> <li>• Recharge(refrigerant gas).</li> </ul>

DAIKIN INDUSTRIES, LTD.

Head office: Umeda Center Bldg., 4-12, Nakazaki-nishi 2-chome, Kita-ku, Osaka 530, Japan  
Phone: (06)373-1201

Tokyo Branch: Shinjyuku Sumitomo Bldg., Nishi-shinjuku, 2-chome, Shinjuku-ku, Tokyo 163, Japan