

Contact Details

Before using the product, please check the guide pages at the front of this catalog.

Internet

<http://www.daikinpmc.com/en/>

For latest information, PDF catalogs and operation manuals

02 Series Stacking Type Pressure Switch

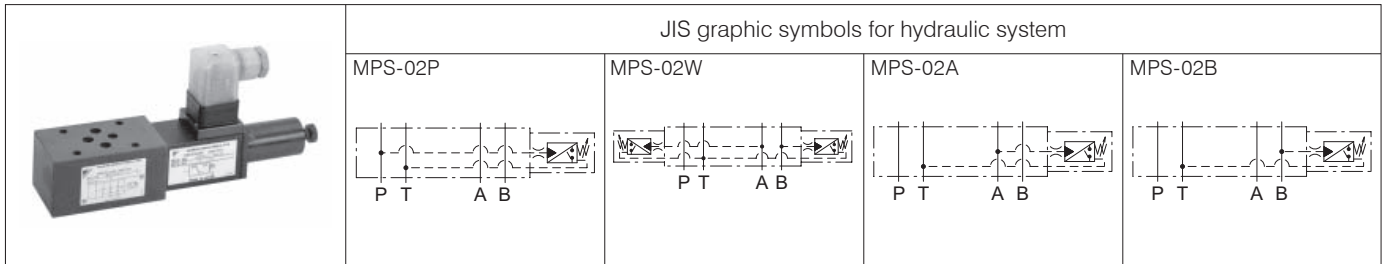

Nomenclature

MPS - **02** ※ - ※ ※ - **60** - ※※※

1 2 3 4 5 6 7

1 Model No.

MPS: Modular stacking type pressure switch

2 Nominal diameter

02: ¼

3 Pressure detection port

P: Port P
W: Port A/B
A: Port A
B: Port B

4 Pressure adjustment range

1: 0.5 to 7 MPa {5 to 70 kgf/cm²}
2: 0.5 to 16 MPa {5 to 160 kgf/cm²}
3: 0.8 to 25 MPa {8 to 250 kgf/cm²}

5 Voltage code *1

A: AC 100 V (50/60 Hz), AC 110 V (50/60 Hz)
B: AC 200 V (50/60 Hz), AC 220 V (50/60 Hz)
P: DC 24 V

6 Design No. (The design No. is subject to change)

7 Option code (See the option code table)

Note: *1 The voltage code applies only to DIN connector type (with lamp) models.

Specifications

Model code	Maximum operating pressure MPa {kgf/cm ² }	Maximum flow rate L/min	Pressure adjustment range MPa {kgf/cm ² }	Permissible back pressure MPa {kgf/cm ² }	Maximum switching frequency Times per minute	Mass kg	Pressure change MPa {kgf/cm ² } per screw revolution
MPS-02※-1※-60	25 {250}	40	0.5 to 7 {5 to 70}	2 {20}	60	1.8 *1	1.2 {12}/revolution
MPS-02※-2※-60			0.5 to 16 {5 to 160}				2.1 {21}/revolution
MPS-02※-3※-60			0.8 to 25 {8 to 250}				3.1 {31}/revolution

Note: For the specifications of the pressure switch, see those for JPS on Page E-62.

*1 The mass of MPS-02W-※※-60 is 2.5 kg.

7: Option code table

7 Code	Option details		
No designation	Lead wire type	Without lamp	Upward
L			Leftward
R			Rightward
D			Downward
C	DIN connector type	Without lamp	Upward
CL			Leftward
CR			Rightward
CD			Downward
CL	Wiring port PG11	With lamp	Upward
CLL			Leftward
CLR			Rightward
CLD			Downward
CG04	DN connector type	Without lamp	Upward
CG04L			Leftward
CG04R			Rightward
CG04D			Downward

Wiring

Refer to Page E-63 for the wiring specifications.

Performance curves (viscosity: 32 mm²/s {cSt})

Pressure drop characteristics

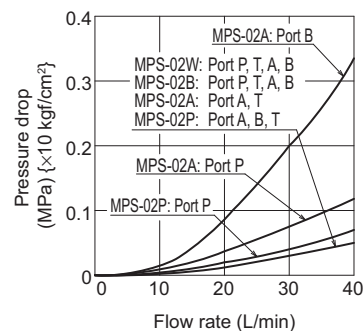

Note: For the direction of the models with option codes L, R, and D, see the external dimension diagrams.

Contact Details

Before using the product, please check the guide pages at the front of this catalog.

Internet

<http://www.daikinpmc.com/en/>

For latest information, PDF catalogs and operation manuals

External dimension diagram

MPS-02W

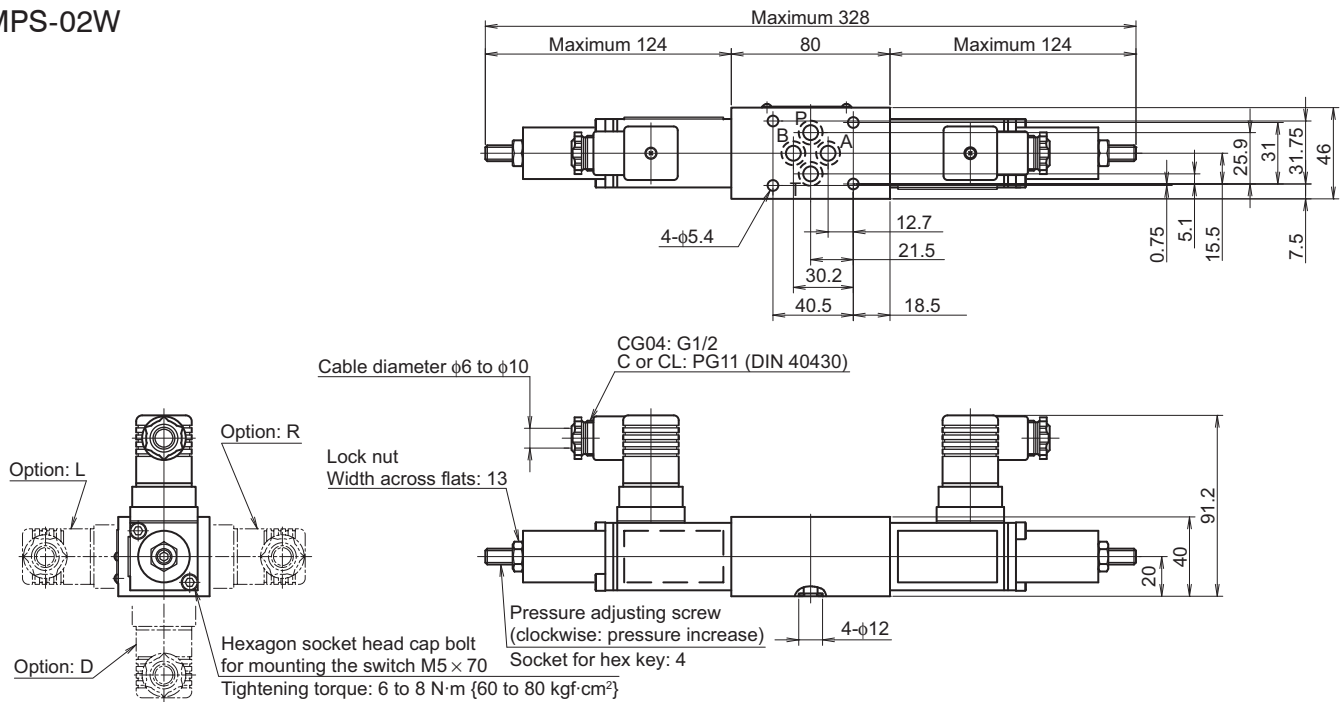

MPS-02P, A, B

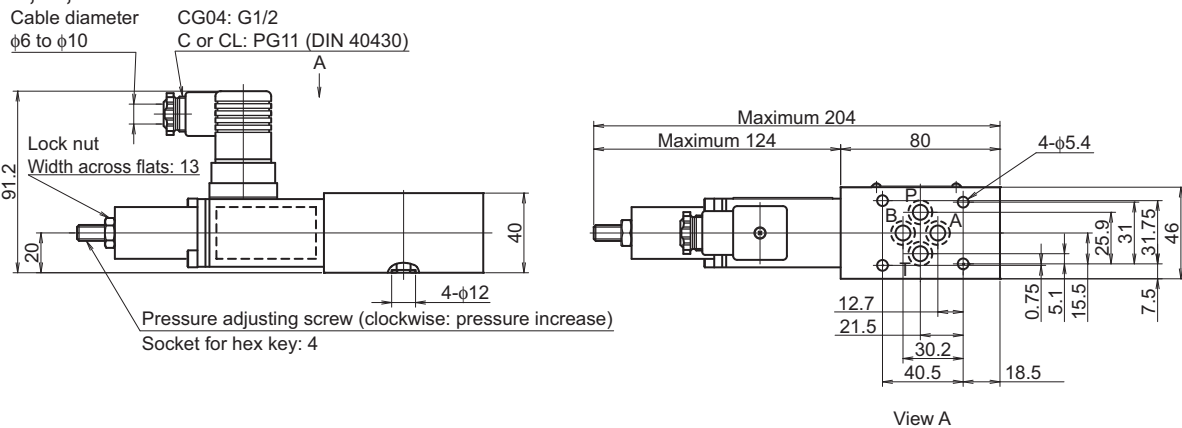

Sectional structural diagram

MPS-02W

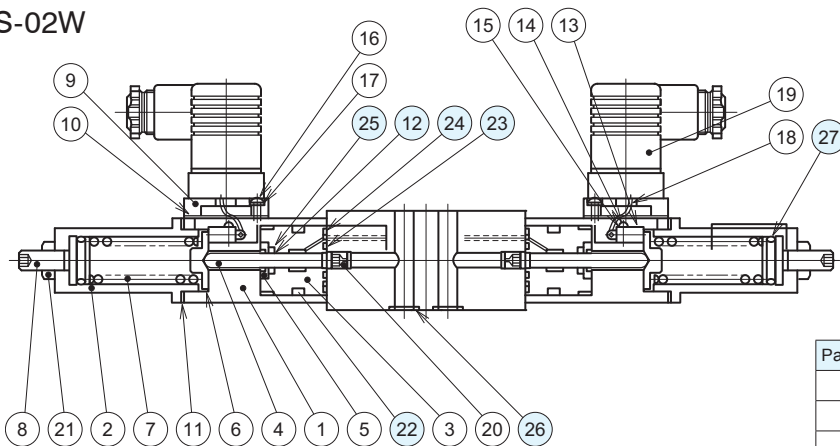

Sealing part table

Part No.	Name	Adjustment range	Quantity	Drawing No.
12	Sealing ring	1st pattern	2 (1)	1845856-3
		2nd pattern	2 (1)	1845856-2
		3rd pattern	2 (1)	1845856-1

Part No.	Name	Quantity	Part specifications
22	O-ring	2 (1)	JIS B 2401 1A P22A
23	O-ring	2 (1)	AS568-013 (NBR, Hs90)
24	O-ring	2 (1)	JIS B 2401 1B P21
25	O-ring	2 (1)	1st pattern: JIS B 2401 1A P8
			2nd pattern: JIS B 2401 1A P7
			3rd pattern: JIS B 2401 1A P6
26	O-ring	4	JIS B 2401 1B P9
27	O-ring	2 (1)	JIS B 2401 1A P15

Note: The quantities given in parentheses are for MPS-02P, A, and B.